

04-343026

5-29-84
approved
S. Shel

PERMIT

P 37059
A 35479

SEWAGE DISPOSAL SYSTEM

MARYLAND STATE DEPARTMENT OF HEALTH*

HOWARD COUNTY
BUREAU OF ENVIRONMENTAL HEALTH
992-2330

ELLICOTT CITY
DISTRICT 4TH

INDEXED
BLDG. PERMIT SIGNED
AND RETURNED _____

DATE May 27, 1986

Donald Parlette IS PERMITTED TO INSTALL _____ ALTER _____

ADDRESS _____ PHONE _____

SUBDIVISION Roxbury ROAD 4040 Roxmill Ct. LOT 17

PROPERTY OWNER Howard Harrison

ADDRESS 10040 Baltimore National Pike E.C.

IF GARBAGE GRINDER IS USED INCREASE SEPTIC TANK CAPACITY BY 50% AND ABSORPTION AREA BY 22%.

GARBAGE GRINDER? YES NO _____
(with disp)

SEPTIC TANK CAPACITY 1500 GALLONS NUMBER OF BEDROOMS 3

DEEP TRENCHES - with disposal - 200 sq.ft. per bedroom. Trench is to be 2 ft. wide
Inlet 3 feet below grade. Maximum depth 8 feet below original grade. 5 feet of stone

below distribution pipe. LOCATION: Start the first trench 127 feet from the
front lot line and 45 feet from the right lot line as seen when facing the property
from Roxmill Ct. Run trenches along contour toward left side of property.

BLDG. PERMIT SIGNED
AND RETURNED 4/7/88
Serial # 17571 - Prod.

PLANS APPROVED BY C. Williams/ R. Hodges DATE 9/26/85

COVER NO WORK UNTIL INSPECTED AND APPROVED.

NEITHER THE HOWARD COUNTY COUNCIL NOR THE HEALTH DEPARTMENT IS RESPONSIBLE FOR THE SUCCESSFUL OPERATION OF ANY SYSTEM.

NOTE: IF TRENCH IS USED CALL FOR INSPECTION BEFORE AND AFTER PLACING GRAVEL IN TRENCH.

NOTE: NO DRY WELL SHALL EXCEED 15 FOOT IN DIAMETER. NO ABSORPTION TRENCH TO EXCEED 100 FEET IN LENGTH.

NOTE: ALL PIPE FROM HOUSE TO SEPTIC TANK MUST BE CAST IRON OR SCHEDULE 40 PVC OR ABS.

PERMIT VOID AFTER THREE YEARS.

NOTE: INSTALL STAND PIPE ON SEPTIC TANK AND DRY WELL. STAND PIPES MUST BE 6 INCHES IN DIAMETER. CAST IRON, CONCRETE OR TERRA COTTA, OR
PVC OR ABS ACCEPTED. IF TOP OF SEPTIC TANK IS DEEPER THAN 3 FEET MANHOLE TO GRADE REQUIRED.

***INSTALLER IS RESPONSIBLE FOR OBTAINING FINAL APPROVAL ON THIS PERMIT**

*CALL 992-2330 FOR INSPECTION OF SEPTIC SYSTEMS.

EH - 2-1082

A 37059 35479

5-29-86
ASAP AM

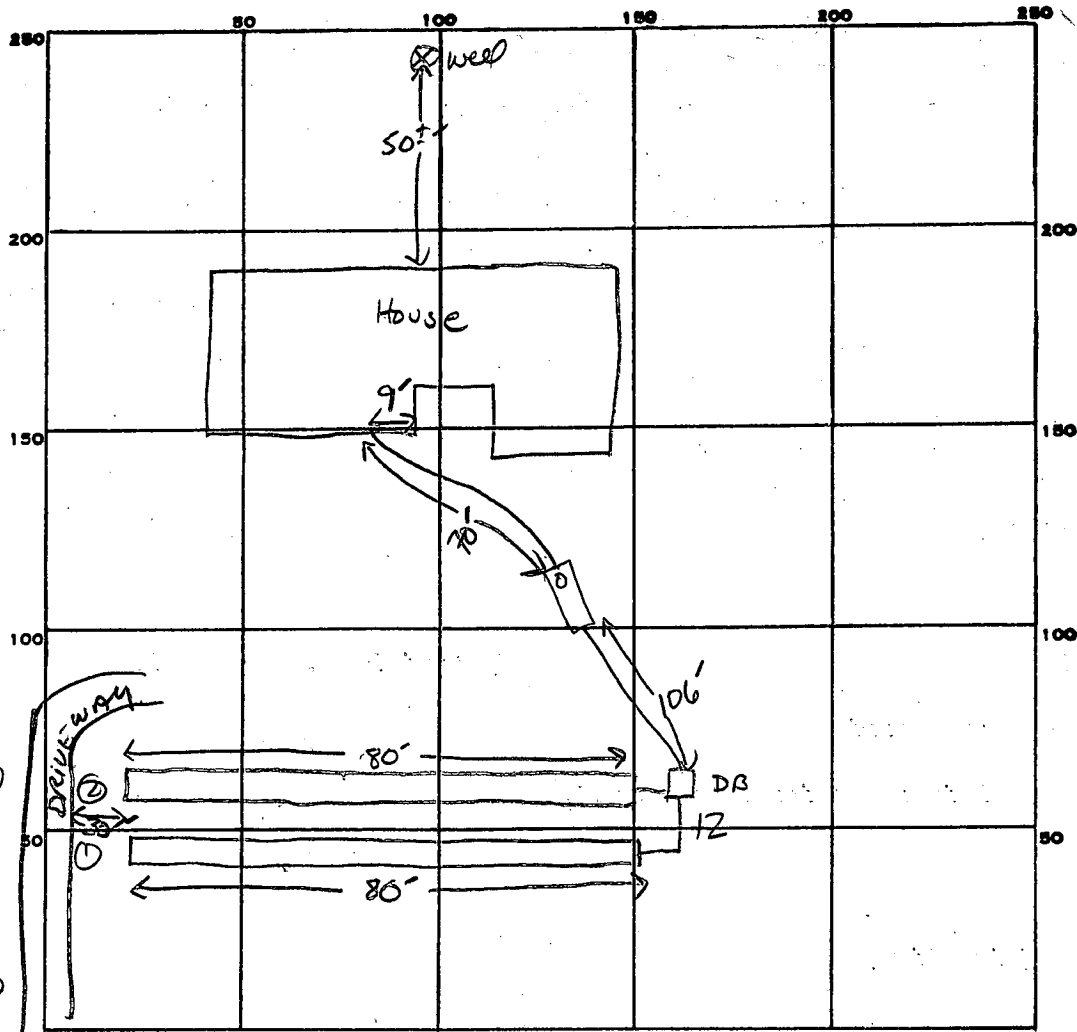

$$\begin{array}{r} 600\phi \\ 10 \\ \hline 55000 \\ 55 \\ \hline 500 \end{array}$$

$$\begin{array}{r} 35.5 \\ 100 \\ \hline 35500 \\ 35 \\ \hline 8800 \end{array}$$

INDICATE NORTH. - NAME ADJOINING ROADWAY AS BASE LINE.

Roxmill Court

PERMIT CARD

SEPTIC TANK, LEVEL 1500 GAL

CLEANOUTS 15

DISTRIBUTION BOX, LEVEL

TILE FIELD, DEPTH 8.5 FT. TRENCH WIDTH 2 FT. INLET 3'

GRAVEL DEPTH 5.5 FT TOTAL LENGTH 80' 80' FT.

NUMBER OF TRENCHES 2 ONE SIDE WALL TOTAL BOTTOM AREA 880 φ

SEEPAGE PITS, INSIDE DIAMETER FT. DEPTH BELOW INLET FT.

ABSORBENT AREA 880 SQ. FT.

REMARKS _____

DATE SYSTEM APPROVED 5.29-86

INSPECTOR J. AHL

APPLICATION

SEWAGE DISPOSAL TESTING

STATE OF MARYLAND - DEPARTMENT OF HEALTH AND MENTAL HYGIENE

A 34579

P _____

HOWARD COUNTY HEALTH DEPARTMENT
ENVIRONMENTAL HEALTH SERVICES
P. O. BOX 476 ELLICOTT CITY, MARYLAND 21043
TELEPHONE: 992-2330

DISTRICT _____

DATE 11/16/84

TO: THE COUNTY HEALTH OFFICER
ELLICOTT CITY, MARYLAND

I, HEREBY, APPLY FOR THE NECESSARY TEST IN ORDER TO CONSTRUCT (OR RECONSTRUCT) A SEWAGE DISPOSAL SYSTEM.

PROPERTY OWNER Roxbury Limited Partnership
ADDRESS 241 W. PATRICK ST. FREDERICK, Md PHONE 1-831-6800
21701

PROPERTY LOCATION:
SUBDIVISION Roxbury LOT NO. 17
ROAD AND DESCRIPTION Roxmill Court

SIZE OF LOT _____ TYPE BLDG. _____ (NUMBER OF BEDROOMS)

THE SYSTEM INSTALLED UNDER THIS APPLICATION IS ACCEPTABLE ONLY UNTIL PUBLIC FACILITIES BECOME AVAILABLE. I FULLY UNDERSTAND THE FEE CONNECTED WITH THE FILING OF THIS PERC TEST APPLICATION IS NON-REFUNDABLE UNDER ANY CIRCUMSTANCES. I ALSO AGREE TO COMPLY WITH ALL M.O.S.H.A. REQUIREMENTS IN TESTING THIS LOT.

Colin K. Jones, Jr. Roxbury Limited Partnership
(SIGNATURE OF APPLICANT)

APPROVED BY _____ FOR _____ DATE _____

REJECTED BY _____ FOR _____ DATE _____

HOLD PENDING FURTHER TESTS _____ DATE _____

REASONS FOR REJECTION OR HOLDING _____

THIS IS NOT A PERMIT

SOIL PROFILE

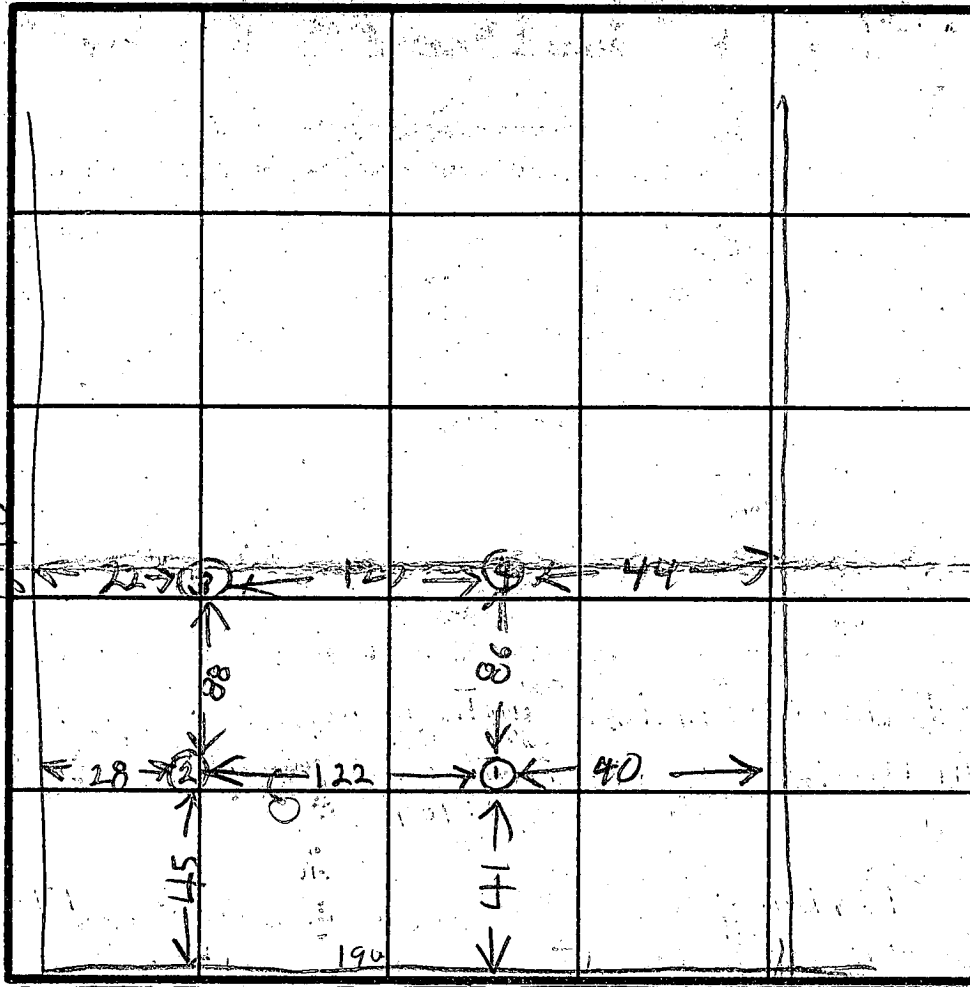
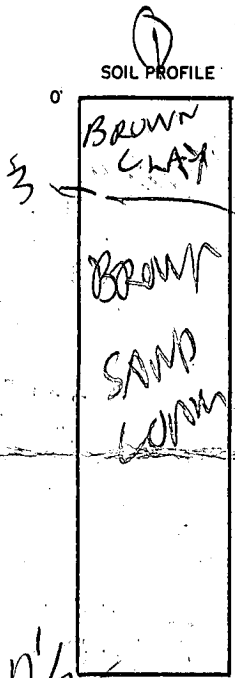

22
9
ELEVATION OF HOLE
④ HIGHEST
③ NEXT HIGH
② LOWEST
① NEXT LOWEST

INDICATE NORTH - NAME ADJOINING ROADWAY AS BASE LINE.

BOX MILL COURT

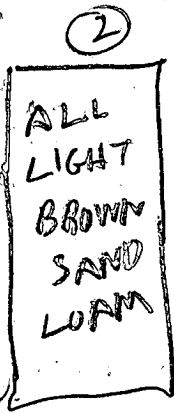

DATE	TEST NO.	DEPTH	PRE-WET		TEST - 1" DROP		TIME
			START	STOP	START	STOP	
11/16/84	1S	4	1009	1012	1012	1018	6
	1V	1 1/2	LOOKS	OK	BELON	3F7	
	2S	2	1012	1020	1020	1026	6
	2V	12	LOOKS	OK			
	3S	3 1/2	1028	1030	1030	1032	2
	3V	1 1/2	LOOKS	OK	BELON	3F7	
	4S	3 1/2	1031	1042	1042	1100	13
	4V	12	LOOKS	OK	BELON	5F	

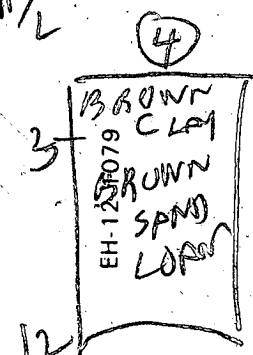
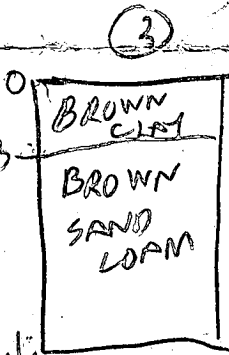

REMARKS _____

TYPE OF SOIL _____

TESTED BY B. HODGES

ALSO PRESENT O. KETTERMAN
EILEEN VINN Real Estate

APPLICATION

SEWAGE DISPOSAL TESTING

STATE OF MARYLAND - DEPARTMENT OF HEALTH AND MENTAL HYGIENE

A 31243
P _____

HOWARD COUNTY HEALTH DEPARTMENT
ENVIRONMENTAL HEALTH SERVICES
P.O. BOX 476 ELLICOTT, MARYLAND 21043
TELEPHONE: 992-2330

DISTRICT 4th.
DATE 9/28/79

TO: THE COUNTY HEALTH OFFICER
ELLICOTT CITY, MARYLAND

I, HEREBY, APPLY FOR THE NECESSARY TEST IN ORDER TO CONSTRUCT (OR RECONSTRUCT) A SEWAGE DISPOSAL SYSTEM.

PROPERTY OWNER J. Garrett Reilly

ADDRESS Roxbury Mills Rd., Glenwood, Md. 21738 PHONE 489-4481

PROPERTY LOCATION:

SUBDIVISION Roxbury LOT NO. 20 new 17

ROAD AND DESCRIPTION Route 97

SIZE OF LOT 3.00 Acres TYPE BLDG. 3 or 4 Bedrooms

THE SYSTEM INSTALLED UNDER THIS APPLICATION IS ACCEPTABLE ONLY UNTIL PUBLIC FACILITIES BECOME AVAILABLE.

I FULLY UNDERSTAND THE FEE CONNECTED WITH THE FILING OF THIS PERC TEST APPLICATION IS NON-REFUNDABLE UNDER ANY CIRCUMSTANCES.

SIGNATURE OF APPLICANT E. Smariga /s/

APPROVED BY R.D. & D.W.M. FOR DRY WELL DATE 12/10/79

REJECTED BY _____ FOR _____ DATE _____

HOLD PENDING FURTHER TESTS _____ DATE _____

REASONS FOR REJECTION OR HOLDING 10/17/79 MORE TESTS R12

12/1/79 - OK HOLD FOR REVIEW (ROCK)

12/5/79 - HOLE IN CENTER - R.D.

12/7/79 OK R.D.

THIS IS NOT A PERMIT

LOT 20

RELATIVE ELEVATION NEW PATTERN

- ① HIGHEST
- ④ NEXT HIGHEST
- ⑤ NEXT LOWEST
- ⑥ LOWEST

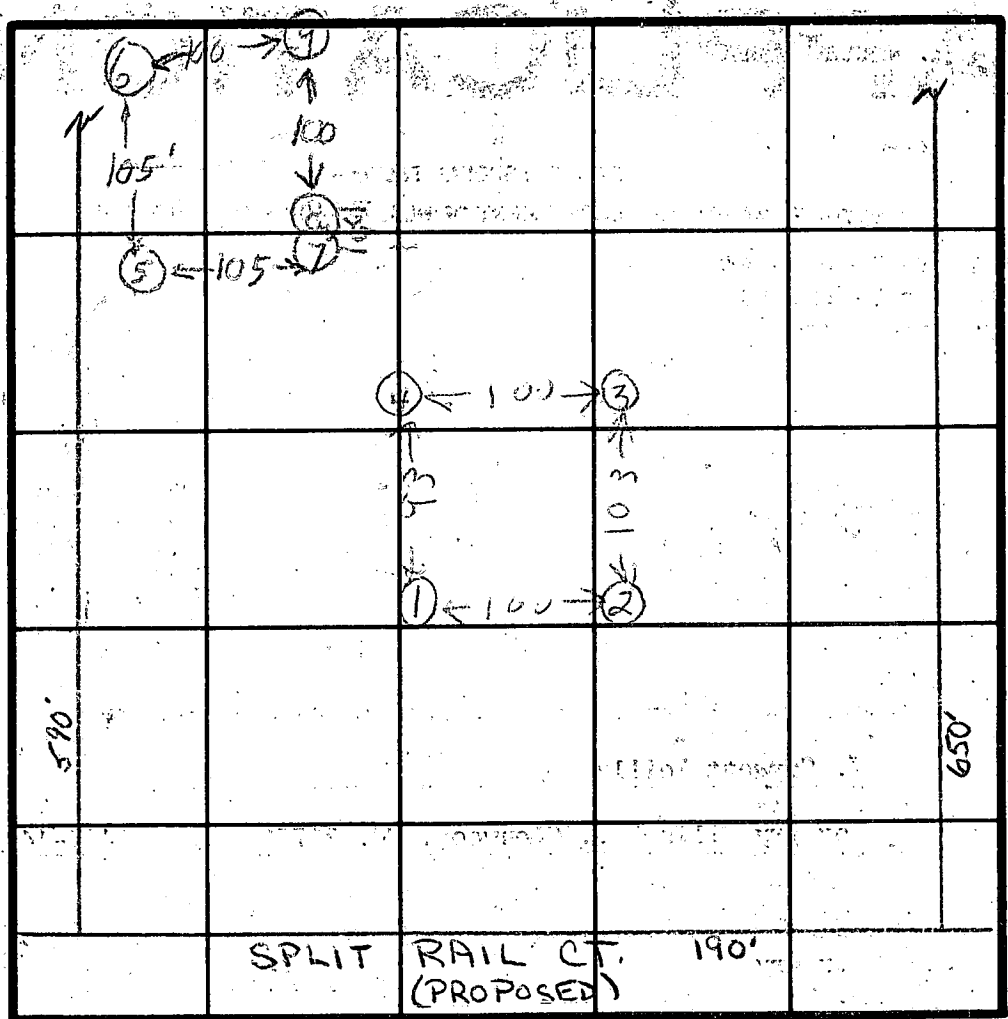

SOIL PROFILE

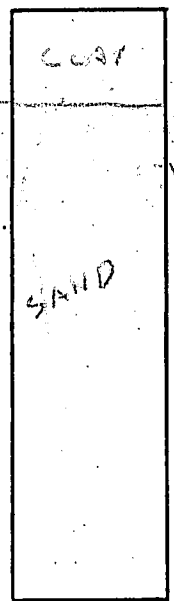

INDICATE NORTH - NAME ADJOINING ROADWAY AS BASE LINE.

DATE	TEST NO.	DEPTH	PRE-WET		TEST - 1" DROP		TIME
			START	STOP	START	STOP	
10/17/79	1D	13 1/2	1033	1041	1041	1056	15
	1S	3 1/2	1031	1034	1034	1038	4
	2D	10 1/2	1039	1041	1041	1045	4
10/17/79	2S	4	1040	1047	1047	1057	10
	2V	11 1/2	ALL SAND & FEW ROCKS				
	3V	3	ROCK BOTTOM				
	4V	4	ROCK BOTTOM				
12/4/79	3D	4 1/2	10:15	10:21	10:21	10:34	13
		13 1/2	10:12	10:17	10:17	10:29	12
	D	4	10:30	10:34	10:34	10:38	5
	D	1 1/2	10:40	10:43	10:43	10:52	7

REMARKS 12/4/79 12V. TOP 3 FT. NOT TESTED

TYPE OF SOIL

TESTED BY RH

ALSO PRESENT HERTSMAN

APPLICATION

SEWAGE DISPOSAL TESTING

STATE OF MARYLAND - DEPARTMENT OF HEALTH AND MENTAL HYGIENE

A 30243
P _____

HOWARD COUNTY HEALTH DEPARTMENT
ENVIRONMENTAL HEALTH SERVICES
P.O. BOX 476 ELLICOTT, MARYLAND 21043
TELEPHONE: 992-2330

DISTRICT 4th.
DATE 9/28/79

TO: THE COUNTY HEALTH OFFICER
ELLICOTT CITY, MARYLAND

I HEREBY APPLY FOR THE NECESSARY TEST IN ORDER TO CONSTRUCT (OR RECONSTRUCT) A SEWAGE DISPOSAL SYSTEM.

PROPERTY OWNER J. Garrett Reilly

ADDRESS Roxbury Mills Rd., Glenwood, Md. 21738 PHONE 489-4481

PROPERTY LOCATION:

SUBDIVISION Roxbury LOT NO. 20

ROAD AND DESCRIPTION Route 97

SIZE OF LOT 3.00 Acres TYPE BLDG. 3 or 4 Bedrooms

THE SYSTEM INSTALLED UNDER THIS APPLICATION IS ACCEPTABLE ONLY UNTIL PUBLIC FACILITIES BECOME AVAILABLE.

I FULLY UNDERSTAND THE FEE CONNECTED WITH THE FILING OF THIS PERC TEST APPLICATION IS NON-REFUNDABLE UNDER

ANY CIRCUMSTANCES.

SIGNATURE OF APPLICANT E. Smariga /s/

APPROVED BY _____ FOR _____ DATE _____

REJECTED BY _____ FOR _____ DATE _____

HOLD PENDING FURTHER TESTS. _____ DATE _____

REASONS FOR REJECTION OR HOLDING _____

10/2/79 - DM 2210 PERC OK RH

THIS IS NOT A PERMIT

new 12
LOT 20

RELATIVE
ELEVATIONS
NEW PATTERN

- ⑦⑩ HIGHEST
- ⑨ NEXT HIGHEST
- ⑤ NEXT LOWEST
- ⑥ LOWEST

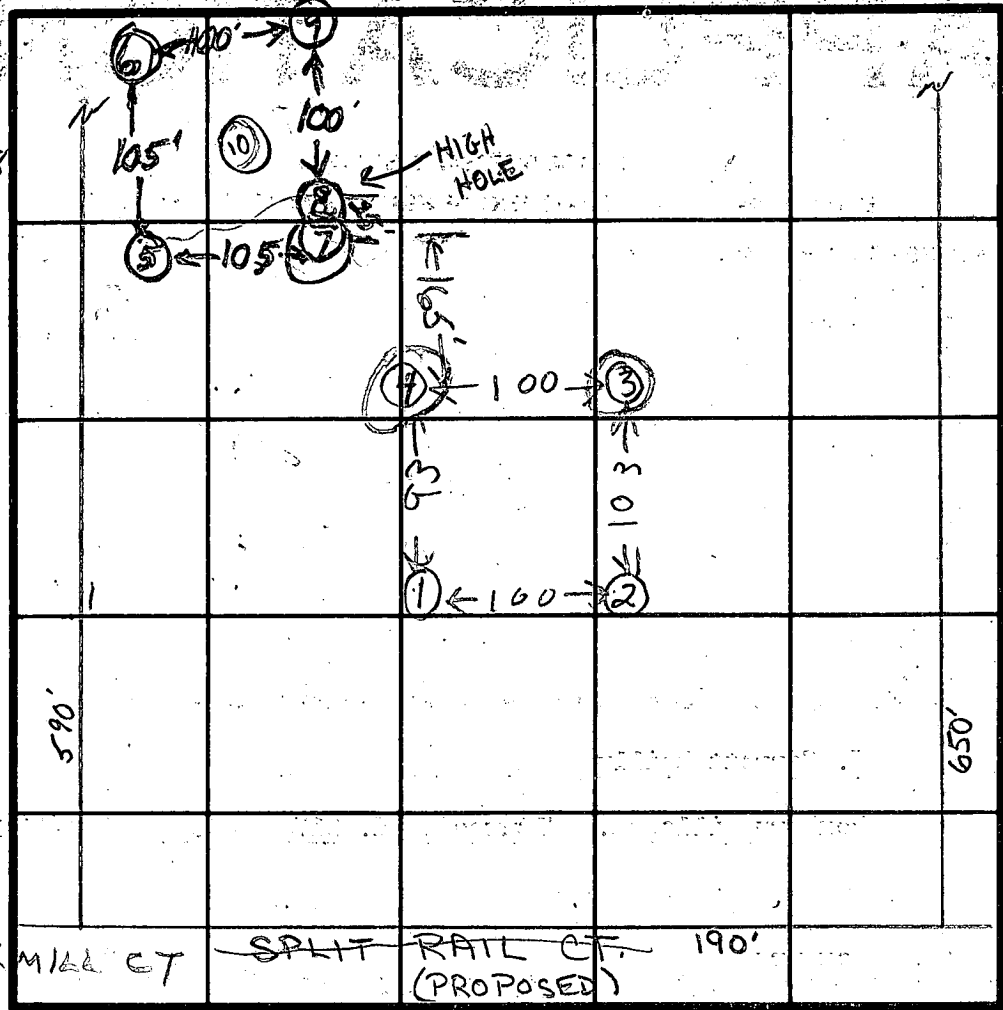

① 5,6,9,8
SOIL PROFILE

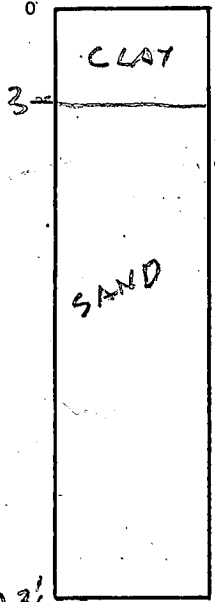

HOLE # 7

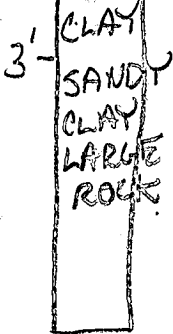

INDICATE NORTH - NAME ADJOINING ROADWAY AS BASE LINE.
10V 13 1/2' GOOD - SEE PROFILE.

DATE	TEST NO.	DEPTH	PRE-WET		TEST - 1" DROP		TIME	
			START	STOP	START	STOP		
10/17/79	1D	13 1/2	10:30	10:41	10:41	10:56	15	
	1S	3 1/2	10:31	10:34	10:34	10:38	4	
	2D	10 1/2	10:39	10:41	10:41	10:45	4	
10/17/79	2S	4	10:40	10:41	10:47	10:57	10	
	2V	11 1/2	ALL SAND & FEW ROCKS					
	3V	3	ROCK BOTTOM					
10/17/79	4V	4	ROCK BOTTOM					
12/4/79	5S	4 1/2	10:13	10:21	10:21	10:34	13	
	5D	13 1/2	10:12	10:17	10:17	10:29	12	
	6S	4"	10:30	10:33	10:33	10:38	5	
	6D	12 1/2	10:30	10:34	10:34	10:44	10	
	8S	5"	10:40	10:44	10:44	10:49	5	
	8D	13 1/2	10:40	10:45	10:45	10:52	7	
12/4/79	9V	8	ROCK BOTTOM					
		12 1/2	TOP SET CLAY BOT 8 1/2 SAND					

9 MIU. AVG.

REMARKS 10/17/79 BACKHOLE PROBLEM TODAY

12/1/79 10V - 13 1/2' SEE PROFILE

TYPE OF SOIL

TESTED BY BH RD RD KETTERMAN
 10/17/79 12/4/79 12/7/79 ALSO PRESENT

C1 **2928** SEQUENCE NO. (OEP USE ONLY)

STATE OF MARYLAND
WELL COMPLETION REPORT
 FILL IN THIS FORM COMPLETELY
 PLEASE PRINT OR TYPE

THIS REPORT MUST BE SUBMITTED WITHIN
 45 DAYS AFTER WELL IS COMPLETED.

1, 2, 3, 4, 5, 6
 (THIS NUMBER IS TO BE PUNCHED
 IN COLS. 3-6 ON ALL CARDS)

COUNTY
 NUMBER **A34579**

DATE Received DATE WELL COMPLETED **01/1/85** Depth of Well **265** (TO NEAREST FOOT) PERMIT NO. FROM "PERMIT TO DRILL WELL" **40-81-0837**

OWNER **HARRISON, HOWARD** last name first name TOWN **GLENWOOD**
 STREET OR RFD **ROXMILL CT**
 SUBDIVISION **ROXBURY ESTATES** SECTION LOT **17**

WELL LOG
 Not required for driven wells

STATE THE KIND OF FORMATIONS PENETRATED, THEIR COLOR, DEPTH, THICKNESS AND IF WATER BEARING

DESCRIPTION (Use additional sheets if needed)	FEET		Check if water bearing
	FROM	TO	
Clay	0	6	
Brown Shale	6	23	
Blue Rock	23	265	

GROUTING RECORD
 WELL HAS BEEN GROUTED (Circle Appropriate Box) **Y** **N**
 TYPE OF GROUTING MATERIAL
 CEMENT **CM** BENTONITE CLAY **BC**
 NO. OF BAGS **6** NO. OF POUNDS **564**
 GALLONS OF WATER **36**
 DEPTH OF GROUT SEAL (to nearest foot)
 from **0** ft. to **23** ft.
 (enter 0 if from surface)

CASING RECORD
 casing types insert appropriate code below
ST CO STEEL CONCRETE
PL OT PLASTIC OTHER

MAIN CASING TYPE **ST** Nominal diameter top (main) casing (nearest inch) **6** Total depth of main casing (nearest foot) **265**

OTHER CASING (if used) diameter inch depth (feet) from to

SCREEN RECORD
 screen type or open hole insert appropriate code below
ST BR HO STEEL BRASS OPEN HOLE
PL OT PLASTIC OTHER

C2
 DEPTH (nearest ft.)
 EACH SCREEN **HO** **25** **265**
 SLOT SIZE 1 2 3
 DIAMETER OF SCREEN (NEAREST INCH)

CIRCLE APPROPRIATE LETTER
A A WELL WAS ABANDONED AND SEALED WHEN THIS WELL WAS COMPLETED
E ELECTRIC LOG OBTAINED
P TEST WELL CONVERTED TO PRODUCTION WELL

I HEREBY CERTIFY THAT THIS WELL HAS BEEN CONSTRUCTED IN ACCORDANCE WITH COMAR 10.17.13 "WELL CONSTRUCTION" AND IN CONFORMANCE WITH ALL CONDITIONS STATED IN THE ABOVE CAPTIONED PERMIT, AND THAT THE INFORMATION PRESENTED HEREIN IS ACCURATE AND COMPLETE TO THE BEST OF MY KNOWLEDGE.

DRILLERS IDENT. NO. **238**
Joseph E. Morgan

DRILLERS SIGNATURE (MUST MATCH SIGNATURE ON APPLICATION)

SITE SUPERVISOR (sign. of driller or journeyman responsible for sitework if different from permittee)

GRAVEL PACK from to
 IF WELL DRILLED WAS FLOWING WELL INSERT F IN BOX 68

OEP USE ONLY (NOT TO BE FILLED IN BY DRILLER)
 T (E.R.O.S.) WQ
 TELESCOPE CASING LOG INDICATOR OTHER DATA

C3
PUMPING TEST
 HOURS PUMPED (nearest hour) **3**
 PUMPING RATE (gal. per min. to nearest gal.) **7**
 METHOD USED TO MEASURE PUMPING RATE **bucket**
 WATER LEVEL (distance from land surface) BEFORE PUMPING **55** WHEN PUMPING **103**
 TYPE OF PUMP USED (for test)
A air **P** piston **T** turbine
C centrifugal **R** rotary **O** other (describe below)
J jet **S** submersible

PUMP INSTALLED
 DRILLER WILL INSTALL PUMP YES NO
 IF DRILLER INSTALLS PUMP, THIS SECTION MUST BE COMPLETED FOR ALL WELLS EXCEPT HOME USE
 TYPE OF PUMP INSTALLED PLACE (A,C,J,P,R,S,T,O) IN BOX - SEE ABOVE:
 CAPACITY: GALLONS PER MINUTE (to nearest gallon)
 PUMP HORSE POWER
 PUMP COLUMN LENGTH (nearest ft.)
 CASING HEIGHT (circle appropriate box and enter casing height)
 + above } LAND SURFACE (nearest foot)
 - below }

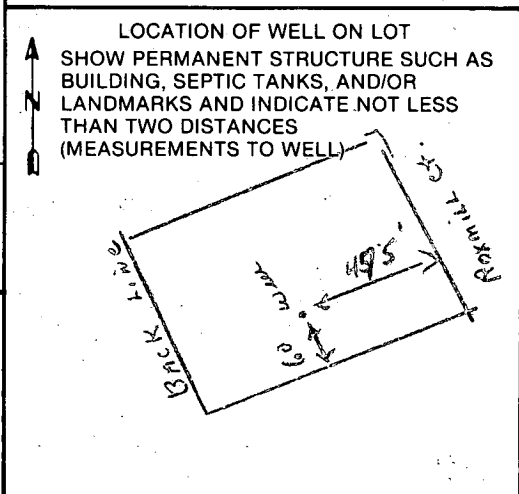

SITE INSPECTION SHEET

OWNER: Howard Harrison

DATE REQUESTED: 8/17/92

ADDRESS: 4040 Roxmill Ct

DRILLER: J Mayne

WELL TAG # _____

COUNTY # A37059

PROPOSAL: Quantity problems in existing well; add 1 well requested

LOCATION DIAGRAM

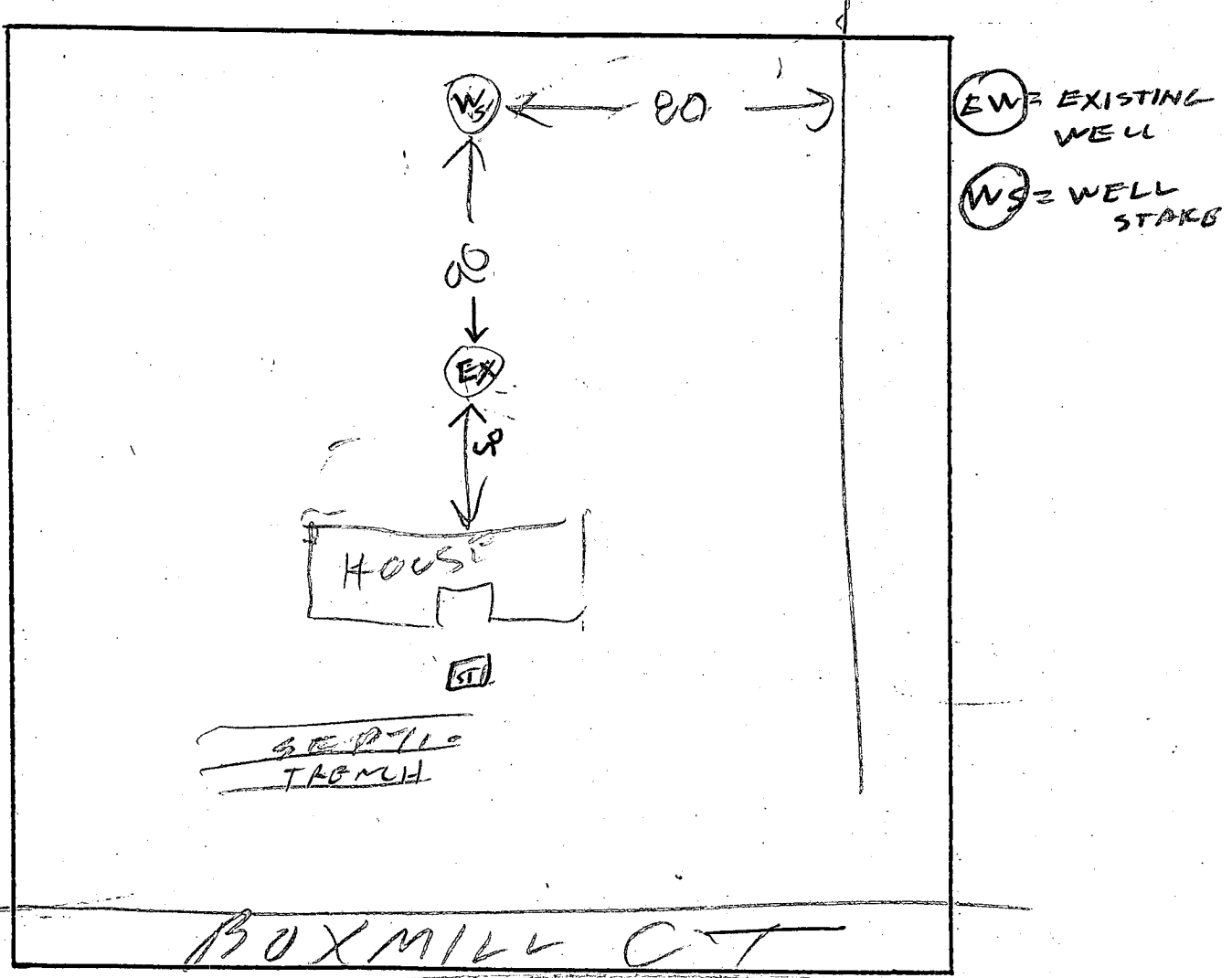

COMMENTS: 8/21/92 WELL STAKE OK
PINK NOTE PUT ON WELL RH

DATE: 8/21/92

INSPECTOR: B. J. Hodge

Howard County Health Department

MR

10/28/92

To: File

T/C w/homeowner 10/28/92

Mr. Harrison indicates well (92-0163) was originally for domestic use due to quantity problems in 81-0837, but further examination of 81-0837 by plumber revealed pump to be the problem.

Pump replaced (in 81-0837), owner now intends to use 92-0163 for outside irrigation only (no house conn), but does not preclude future home use if need should arise.

System not operating yet (held over til spring)
Date: to avoid need for "winterizing", but ^{owner} is willing to be sampled in spring.

HD-170

B 1 00735

SEQUENCE NO. (DP USE ONLY)

STATE OF MARYLAND APPLICATION FOR PERMIT TO DRILL WELL please print or type

STATE PERMIT NUMBER

HO-92-0163 fill in this form completely

(THIS NUMBER IS TO BE PUNCHED IN COLS. 3-6 ON ALL CARDS)

Date Received (APA)

081792

OWNER INFORMATION

HARRISON HOWARD

4040 ROXMILL CT

CLEWOOD MD

B 3

LOCATION OF WELL

HOWARD

8 COUNTY 21

SECTION 44 46 LOT 17

CLEWOOD

MILES FROM TOWN (enter 0 if in town) 2 1/2 MI

DRILLER INFORMATION

Joseph L. Wayne 238 77 License No. 80

Joseph L. Wayne Well Drilling

5512 Ridge Rd. Mt. Airy, Md. 21771

Signature Date 8/17/92

B 4

DIRECTION OF WELL FROM TOWN (CIRCLE BOX)

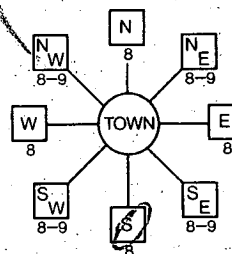

4040 Roxmill Court

NEAR WHAT ROAD

ON WHICH SIDE OF ROAD (CIRCLE APPROPRIATE BOX)

400 DISTANCE FROM ROAD

ENTER FT or MI FT

B 2

WELL INFORMATION

APPROX. PUMPING RATE (GAL. PER MIN.) 5

AVERAGE DAILY QUANTITY NEEDED (GAL. PER DAY) 500

USE FOR WATER (CIRCLE APPROPRIATE BOX)

- HOME (SINGLE OR DOUBLE HOUSEHOLD UNIT ONLY)
FARMING (LIVESTOCK WATERING & AGRICULTURAL IRRIGATION)
INDUSTRIAL, COMMERCIAL, STATE AND FEDERAL GOV. OTHER (REQUIRES APPROPRIATION PERMIT)
PUBLIC OR PRIVATE WATER COMPANY (REQUIRES APPROPRIATION PERMIT AND STATE HEALTH DEPARTMENT APPROVAL)
TEST, OBSERVATION, MONITORING (MAY REQUIRE APPROPRIATION PERMIT)

NOT TO BE FILLED IN BY DRILLER HEALTH DEPARTMENT APPROVAL

HOWARD A 34579 COUNTY NAME COUNTY NO.

STATE SIGNATURE DATE ISSUED

082192 Signature of Joseph L. Wayne 2/21/92

NORTH GRID 520000 EAST GRID 0786000

APPROXIMATE DEPTH OF WELL 260 FEET

APPROXIMATE DIAMETER OF WELL 6 INCH

METHOD OF DRILLING (circle one)

- BORED (or Augered) JETTED Jetted & DRIVEN
AIR-ROTARY AIR-PERCussion ROTARY (Hydraulic Rotary)
CABLE REVerse-ROTary Drive-POINT

SHOW MAJOR FEATURES OF BOX & LOCATE WELL WITH AN X

SOURCES OF DRILLING WATER 1. WELL

WRITE THE BOX NUMBER FROM THE MAP HERE

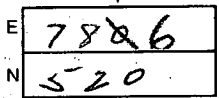

DRAW A SKETCH BELOW SHOWING LOCATION OF WELL IN RELATION TO NEARBY TOWNS AND ROADS AND GIVE DISTANCE FROM WELL TO NEAREST ROAD JUNCTION

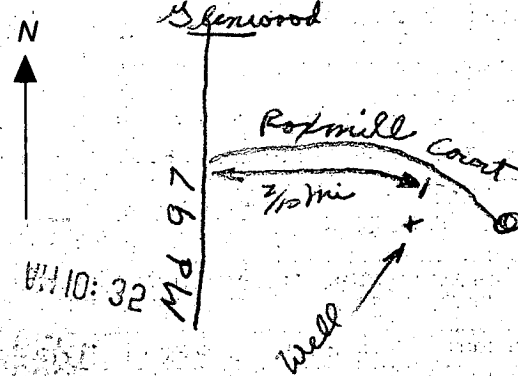

REPLACEMENT OR DEEPEINED WELLS (CIRCLE APPROPRIATE BOX)

- THIS WELL WILL NOT REPLACE AN EXISTING WELL
THIS WELL WILL REPLACE A WELL THAT WILL BE ABANDONED AND SEALED
THIS WELL WILL REPLACE A WELL THAT WILL BE USED AS A STANDBY
THIS WELL WILL DEEPEIN AN EXISTING WELL

PERMIT NUMBER OF WELL TO BE REPLACED OR DEEPEINED (IF AVAILABLE)

Not to be filled in by driller (OEP USE ONLY)

APPROX. PERMIT NUMBER GAP

FORCE RW PERMIT NO. HO-92-0163

SPECIAL CONDITIONS

C1 6753 SEQUENCE NO. (DENV USE ONLY)

STATE OF MARYLAND WELL COMPLETION REPORT

THIS REPORT MUST BE SUBMITTED WITHIN 45 DAYS AFTER WELL IS COMPLETED.

(THIS NUMBER IS TO BE PUNCHED IN COLS. 3-6 ON ALL CARDS)

COUNTY NUMBER A34579

ST/CO USE ONLY DATE Received

DATE WELL COMPLETED

Depth of Well

OK MR 9/9/92 PERMIT NO. FROM "PERMIT TO DRILL WELL" HO-92-9163

OWNER HARRISON HOWARD last name first name STREET OR RFD 4040 BOXMILL CT TOWN GLENWOOD SUBDIVISION BUXBURY SECTION LOT 17

WELL LOG Not required for driven wells STATE THE KIND OF FORMATIONS PENETRATED, THEIR COLOR, DEPTH, THICKNESS AND IF WATER BEARING

Table with columns: DESCRIPTION (Use additional sheets if needed), FEET (FROM, TO), Check if water bearing. Includes handwritten entries: SANDSTONE 0-39, GRAY MICH. ROCK 39-380.

GROUTING RECORD WELL HAS BEEN GROUTED (Y) NO (N) TYPE OF GROUTING MATERIAL CEMENT (CM) BENTONITE CLAY (BC) NO. OF BAGS 8 NO. OF POUNDS 450 GALLONS OF WATER 142 DEPTH OF GROUT SEAL (to nearest foot) from 0 ft. to 37 ft.

CASING RECORD casing types insert appropriate code below: ST (STEEL), CO (CONCRETE), PL (PLASTIC), OT (OTHER). MAIN CASING TYPE ST, Nominal diameter 4, Total depth 42.

OTHER CASING (if used) diameter inch, depth (feet) from to.

SCREEN RECORD screen type or open hole insert appropriate code below: ST (STEEL), BR (BRASS), HO (OPEN HOLE), PL (PLASTIC), OT (OTHER).

DEPTH (nearest ft.) 41.380. E A C H S C R E E N 1 2 3. SLOT SIZE 1 2 3. DIAMETER OF SCREEN (NEAREST INCH) from to.

GRAVEL PACK IF WELL DRILLED WAS FLOWING WELL INSERT F. IN BOX 68.

OEP USE ONLY (NOT TO BE FILLED IN BY DRILLER) T (E.R.O.S.) W Q 70 72 74 75 76. TELESCOPE CASING LOG INDICATOR OTHER DATA.

PUMPING TEST HOURS PUMPED (nearest hour) 3. PUMPING RATE (gal. per min. to nearest gal.) 30. METHOD USED TO MEASURE PUMPING RATE AIR. WATER LEVEL (distance from land surface) BEFORE PUMPING 2. WHEN PUMPING 360. TYPE OF PUMP USED (for test) A (air), P (piston), T (turbine), C (centrifugal), R (rotary), O (other), J (jet), S (submersible).

PUMP INSTALLED DRILLER WILL INSTALL PUMP YES (O). IF DRILLER INSTALLS PUMP, THIS SECTION MUST BE COMPLETED FOR ALL WELLS EXCEPT HOME USE. TYPE OF PUMP INSTALLED PLACE (A,C,J,P,R,S,T,O) IN BOX - SEE ABOVE. CAPACITY: GALLONS PER MINUTE (to nearest gallon), PUMP HORSE POWER, PUMP COLUMN LENGTH (nearest ft.), CASING HEIGHT (circle appropriate box and enter casing height) (+ above, - below) LAND SURFACE (nearest foot).

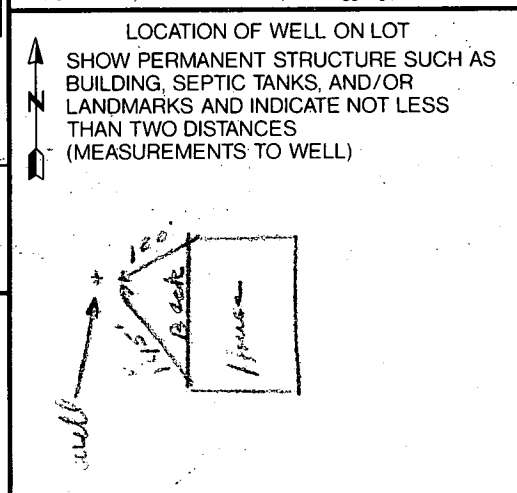

A A WELL WAS ABANDONED AND SEALED WHEN THIS WELL WAS COMPLETED. E ELECTRIC LOG OBTAINED. P TEST WELL CONVERTED TO PRODUCTION WELL.

I HEREBY CERTIFY THAT THIS WELL HAS BEEN CONSTRUCTED IN ACCORDANCE WITH COMAR 26.04.04 "WELL CONSTRUCTION" AND IN CONFORMANCE WITH ALL CONDITIONS STATED IN THE ABOVE CAPTIONED PERMIT, AND THAT THE INFORMATION PRESENTED HEREIN IS ACCURATE AND COMPLETE TO THE BEST OF MY KNOWLEDGE.

DRILLERS IDENT. NO. 998. DRILLERS SIGNATURE (MUST MATCH SIGNATURE ON APPLICATION). SITE SUPERVISOR (sign. of driller or journeyman responsible for sitework if different from permittee).

10/6/92

HOWARD COUNTY HEALTH DEPARTMENT
Bureau of Environmental Health
3525-H Ellicott Mills Drive
Ellicott City, MD 21043
461-9933

10/6/92
No unapproved
alterations
For irrigation
only

APPLICATION FOR PITLESS ADAPTER, WELL PUMP AND PRESSURE TANK INSTALLATION

New Installation
Replacement

Receipt # _____
Date 9-30-91

Name of Installer Allan M. Van Smaut Inc Telephone 442-2221

License Number 1862
Certified Well Pump Installer _____ Well Driller _____ Registered Plumber

Name of Property Owner Buddy Harrison Telephone 442-2078
Subdivision _____ Lot # _____ Well Tag # HO-92-0163
Site Address 4040 Rock Mill Cr

Surge system (all covered) only per Mr. Danny Math

Pump
1. Type
a. Deep well jet _____
b. Shallow well jet _____
c. Submersible
2. Make Goulds
3. Model # _____
4. Capacity _____ GPM

Motor
1. Horsepower 2 HP
2. RPM _____
3. Voltage _____
a. 110 _____
b. 220

Pitless Adapter
1. Make Hannwald
2. Model # _____
3. Depth 3 FT

5. Pump exceeds well capacity Yes _____ No
6. If Yes, is low pressure cutoff switch installed? Yes No _____
7. What methods are used to protect the pump and electrical wiring from vibrations? Torque arrestors _____ Cable guards Other _____

Tank
1. Capacity 42
2. Pressure relief valve? yes

Piping
1. Type #160
2. Size 1"
3. NSF and/or BOCA Code approved yes
4. Depth of supply line 3 FT

Well data
1. Depth 345 ft.
2. Yield 20 GPM
3. Static water level _____ ft.
4. Will water supply be disinfected by installer? yes

For sprinkler use only

I understand that it is my responsibility to notify the Howard County Health Department when the installation is ready for inspection (otherwise this permit is null and void).

All information given above is true to the best of my knowledge.

Signature of Applicant: [Signature]

Date: Sept 30, 1992

Note: A sticker indicating approval/status of the installation will be placed on the well casing at the time of the inspection.

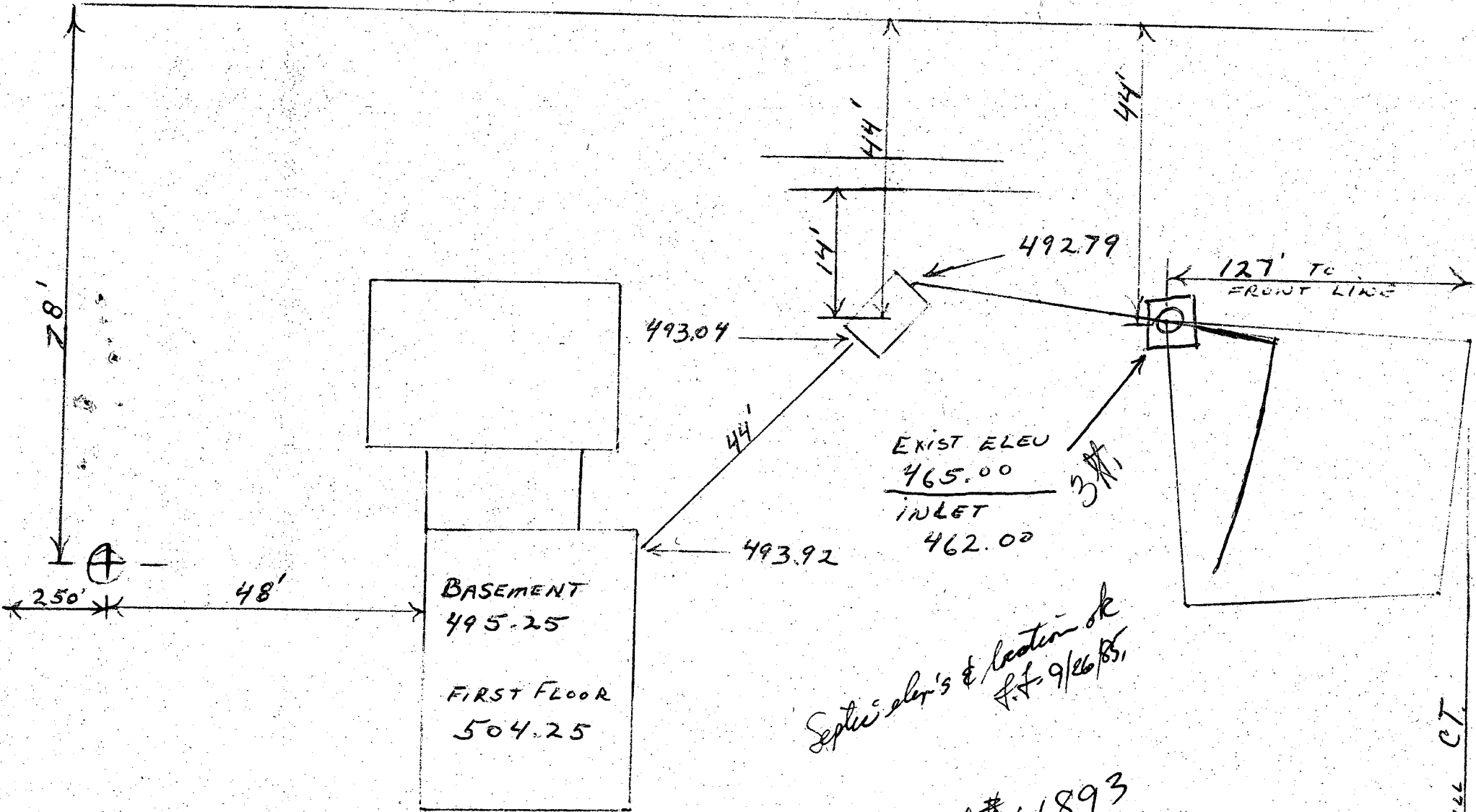

Septic elev's & location ok
S.F. 9/26/85

B.P. appl # 66893
BLDG. PERMIT SIGNED
AND RETURNED

EN. Dept.

Rox Mill CT.

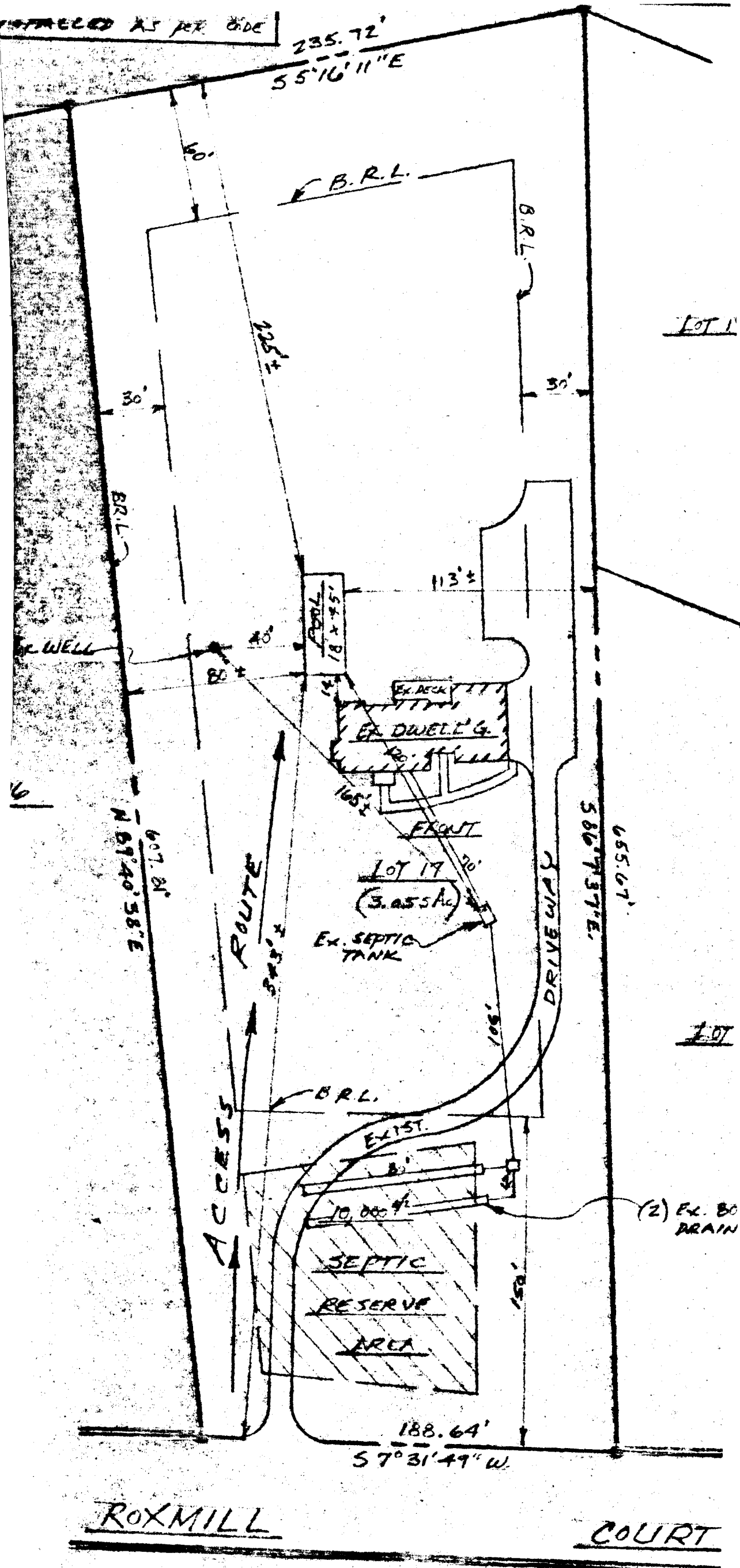

ROXMILL

COURT

4/7/88 - OK TO SIGN
SITE PLAN NO PROBL
 SCALE: 1"=50'

4040 ROXMILL CT.
 HOWARD COUNTY, MD. 21738
"ROXBURY MILL"
 Lot 17