

Record Detail * (This section is required.)

Permit Type Building/Residential/Misc/Pool Spa Permit Number B25005472 Opened Date 12/13/2025

Description of Work SFD/ construct a 18' x 36' non diving inground concrete pool and 600 sq. ft pool patio W/ FENCE TO CODE

Online BP. g/l 12/15/25

check spelling

Address * (This section is required.)

Search Reset Clear Get Parcel & Owner

Street # 14704 Street Name CARRIAGE MILL Street Type DR Unit Type --Select-- Unit # X Coordinate -77.02447 Y Coordinate 39.32329 City WOODBINE State MD Zip Code 21797 Primary Yes

Parcel * (This section is required.)

Search Reset Clear Get Address & Owner

GIS ID * 909011 Parcel 158 Parcel Area 1.44 Land Value 300600 Improved Value 635700 Exemption Value 335100 Plan Area RURAL

Legal Description IMPSLOT 2 1.44 A[]14704 CARRIAGE MILL DR[]CARRIAGE MILL FARMS PH I

check spelling

Block 2 Lot 2 Census Tract 604001 Council Dist 5 Inspection Dist Supervisor Dist Map # DAP Zone Plan Area State Tax Id 1404358279 Subdivision Name CARRIAGE MILL FARMS Section Area Tax Map 8 Grid 8-22 Zoning District RC-DEO ADC Map 4692-G9 SDP No. Final Plan No. WP File No. Record Plat No. 12215 WS Contract No. FDP No. Primary Yes Owner Occupied Year Built 1999 Historic District Flood Plain Historic District Registry No. Stat Area 4-05 Building No

Owner * (This section is required.)

Search Reset Clear

Name * REED I Address Line 1 14704 Carriage Mill Dr Address Line 2

Address Line 3

Mail City Woodbine Mail State MD Mail Zip Code 21797

Approved Septic System Plan Howard County Health Department D Bernard 12-22-25 Signature Date

ca

[Handwritten signature]

Note:
All spoils to be taken away

CARRIAGE MILL DRIVE

N 28°51'38" E
50' R/W
10.00'

10' PUBLIC TREE MAINTENANCE EASEMENT

LOT 5

N 61°08'22" W
444.49'

EXISTING 24" PRIVATE USE-IN-COMMON
INGRESS/EGRESS EASEMENT FOR LOTS
3 & 4

Pool eq.

Access

LOD
2,800 sq. ft

Proposed 18' x 36' pool
648 sq. ft
19,614 gals
98 cu. yds

S 61°08'22" E 310.00'

PIN/CAP FOUND

PIN/CAP FOUND

LOT 1

Proposed fence to code

HOUSE DETAIL
DETAIL NOT TO SCALE

silt fence

Proposed fence

LOD

silt fence

Proposed 600 sq. ft
pool patio

10,000 Sq' PRIVATE
SEWAGE EASEMENT
AS SCALED FROM PLAT

LOT 2
43,095 Sq'±

10' PUBLIC TREE MAINTENANCE EASEMENT
VEHICULAR INGRESS/EGRESS RESTRICTED

N 61°08'22" W 347.80'

CONC PORCH

#14704
2 STORY
FRAME

CHIM.

MACADAM DRIVEWAY

ENCLOSED
WOOD DECK

BAY

BSMT.
ENT.

Reed Candace
14704 Carriage Mill Dr
Woodbine MD 21797

city/septic
print on 11x17 sheet

Scale: 1" = 60'
District: 04
Subdivision: 1003
Account #: 358279
Map: 0008, Grid: 0016, Parcel: 0158
Howard County

The purpose of this drawing is to locate, describe, and represent the positions of buildings and substantial improvements affecting the property shown hereon, being known as:

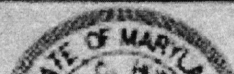

LOCATION DRAWING
14704 CARRIAGE MILL DRIVE

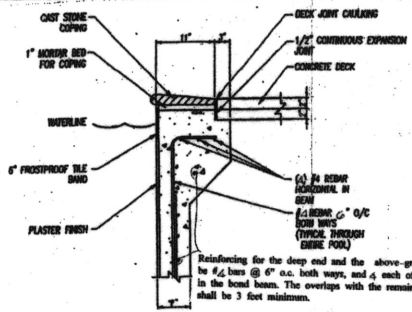

MAIN POOL BEAM DETAIL
SCALE: 1"=1'-0"

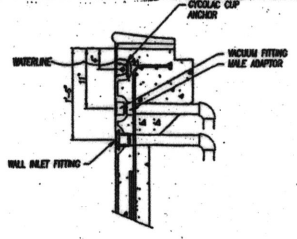

WALL INLET, VACUUM FITTING & CUP ANCHOR DETAIL
SCALE: 1"=1'-0"

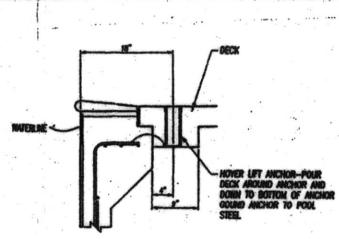

(OPTIONAL) HANDICAP LIFT ANCHOR DETAIL
SCALE: 1"=1'-0"

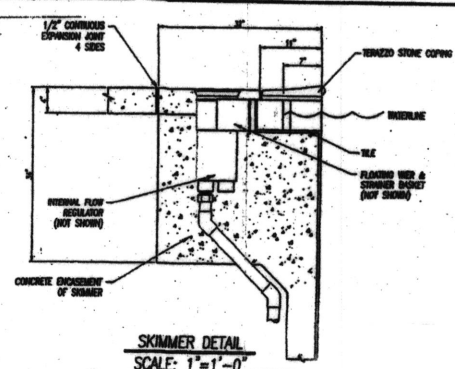

SKIMMER DETAIL
SCALE: 1"=1'-0"

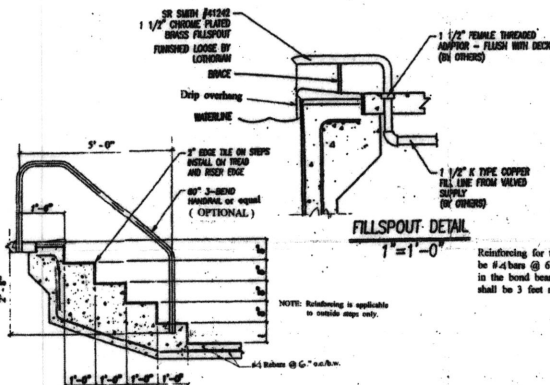

FILLPOUT DETAIL
SCALE: 1"=1'-0"

MAIN POOL STEP DETAIL
SCALE: 1/2"=1'-0"

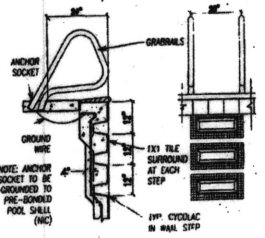

NOTE: ALL BONDING CONNECTIONS ARE BY OTHERS

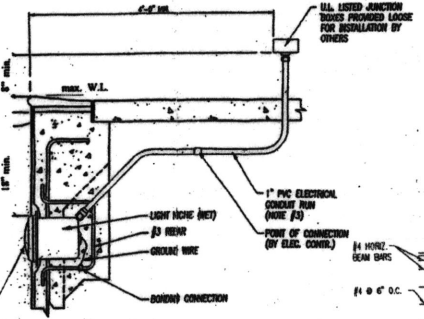

LIGHT FIXTURE DETAIL
SCALE: 1"=1'-0"

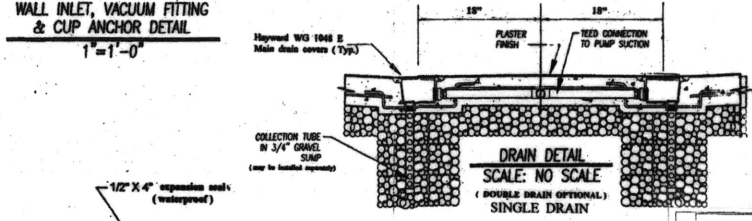

DRAIN DETAIL
SCALE: NO SCALE
(DOUBLE DRAIN OPTIONAL)
SINGLE DRAIN

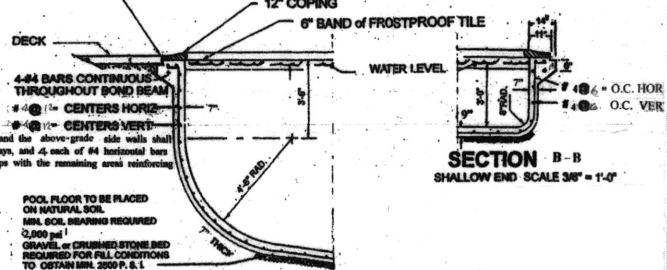

SECTION A-A DEEP END
SCALE 3/8"=1'-0"

POOL FLOOR TO BE PLACED ON NATURAL SOIL. MIN. SOIL BEARING REQUIRED 2,000 psi. GRAVEL OR CRUSHED STONE REQUIRED FOR FILL CONDITIONS TO OBTAIN MIN. 2000 P.S.I.

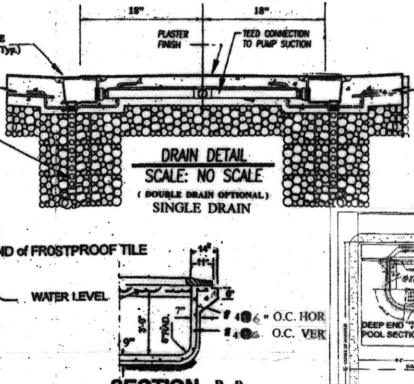

SECTION B-B SHALLOW END
SCALE 3/8"=1'-0"

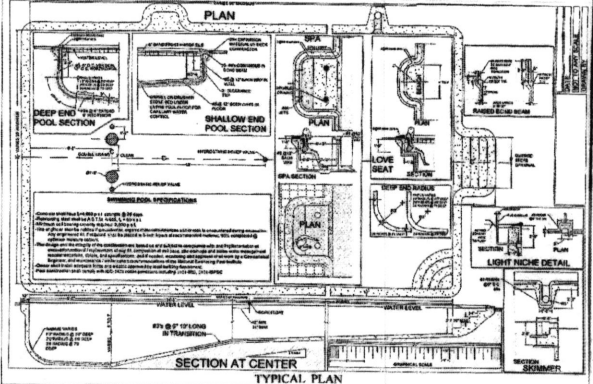

SECTION AT CENTER
TYPICAL PLAN

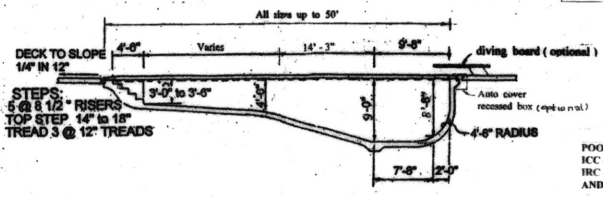

SECTION C-C
NO SCALE

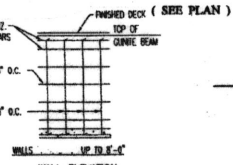

WALL ELEVATION
SCALE: 1/4"=1'-0"

POOL CONSTRUCTION SHALL COMPLY WITH ICC-2021, 2022 CODES PROVISIONS, INCLUDING IRC-2021, 2022, IBC-2021, 2022, ISPCS SECTIONS AND POOL SPECIFICATIONS, AMENDMENTS.

Professional Certificate. I hereby certify that these drawings have been prepared, completed, and approved by me, and that I am a duly Licensed Professional Engineer under the laws of the State of Maryland. Expires 10/15/2027 License No. PE 9514

Approved only for the limited purpose of providing the general guidelines with the structural design and not to constitute complete design and specifications for construction. Structural, plumbing or electrical systems and components are to be shown, methods or procedures of construction or installation are to be shown only for general information.

PATRIOT POOLS

225 TIDEWATER DR., CENTREVILLE, MD. 21617
1-410-980-8450
patriotpooland.com

OWNERSHIP OF DOCUMENTS
NOTICE: DRAWINGS AND SPECIFICATIONS, AS PREPARED BY PATRIOT POOLS, INC., ARE THE PROPERTY OF PATRIOT POOLS, INC. AND ARE NOT TO BE REPRODUCED, COPIED, OR TRANSMITTED IN ANY FORM OR BY ANY MEANS, WITHOUT THE WRITTEN PERMISSION OF PATRIOT POOLS, INC.

SCALE AS SHOWN
DATE 10 DECEMBER, 2023
DRAWN: A. E.



C.E.M., INC.
CONCRETE & CONCRETE INC. OF MD.
PO BOX 3418
Call 410-437-2000
www.ceminc.com

PROPOSED
SWIMMING POOL
AT

STRUCTURAL
DETAILS
(sheet)