

TYP. CROSS SECTION

SEE DETAIL



Professional Certification.
 I hereby certify that these documents were prepared or approved by me, and that I am a duly licensed professional engineer under the laws of the State of Maryland, License No. 16053, Expiration Date: 06-04-2024, per Code of Maryland Regulations 09.23.03.10

Revisions:	

BUILDING SIZE: 50x50x14'-3"
DRAWN BY: JOSH DAY
CHECKED BY:
Job Number: PRICE-001

DATE: 06/15/2023
SHEET: TYP
Cross Section

James A. Koppenhaver, P.E.
 575 Van Reed Rd
 Wyomissing, PA 19610
 484-794-9949
 koppenhaverpe@gmail.com

PPB. Inc.
 Pioneer Pole Buildings, Inc.
 716 South Rt. 183
 Schuylkill Haven, PA 17972
 1-888-448-2505 Toll Free

JOB SITE ADDRESS:
 899 THE OLD STATION COURT
 WOODBINE, MD 21797

CUSTOMER ADDRESS:
 PETER PRICE
 899 THE OLD STATION COURT
 WOODBINE, MD 21797
 H: 410-299-5933
 C: 410-299-9271

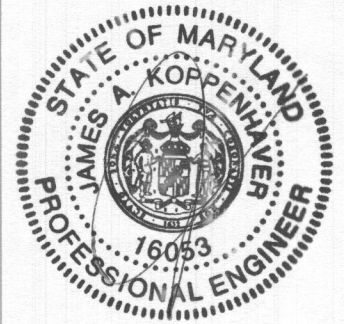

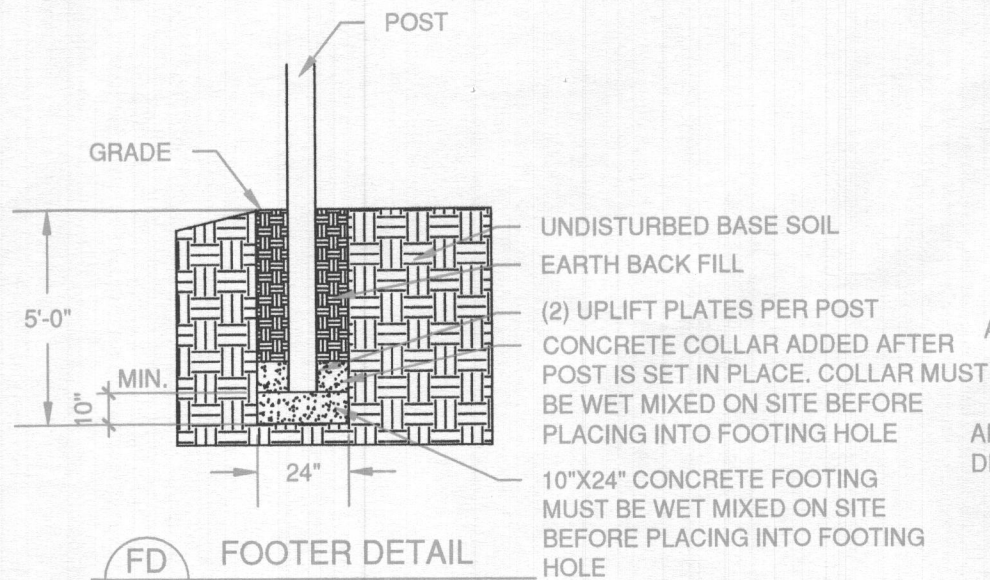

FD 1 FOOTER DETAIL

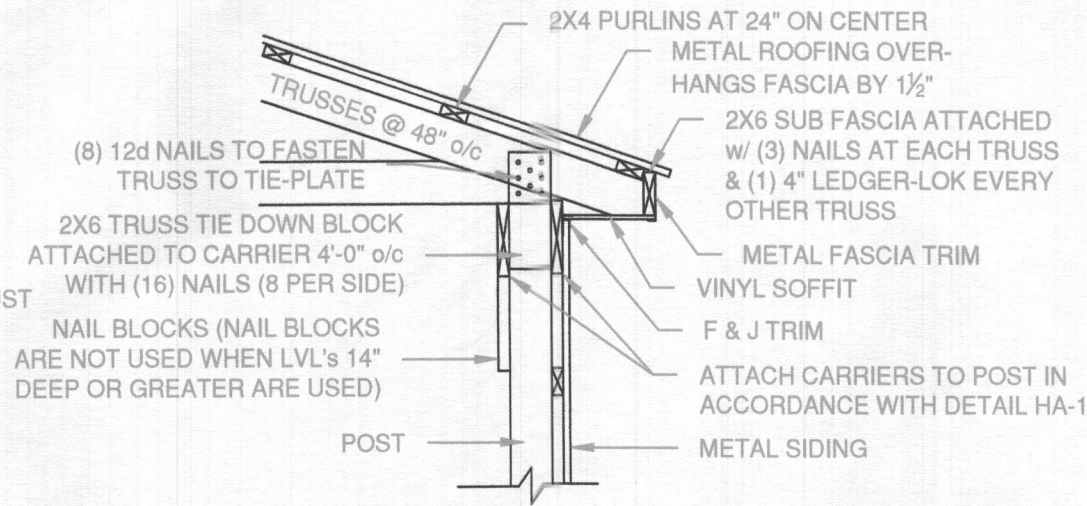

RE 3 ROOF EDGE DET.

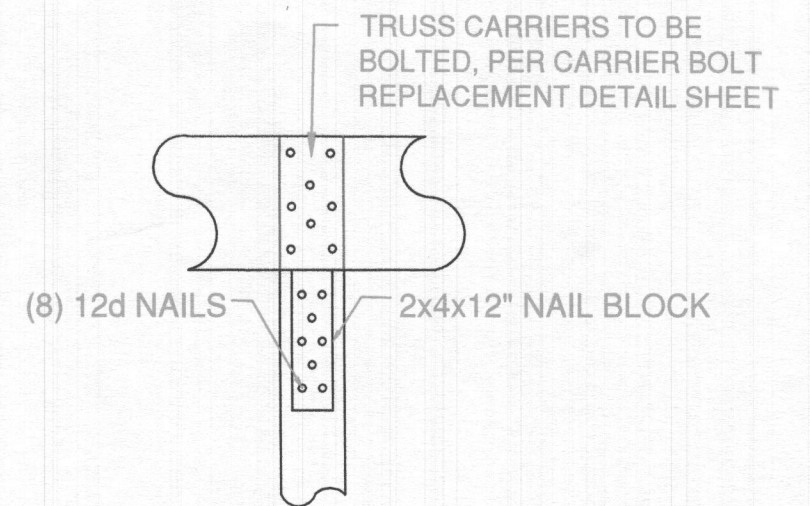

HA 1 1.5" x 11.25" LVL HEADER ATTACHMENT

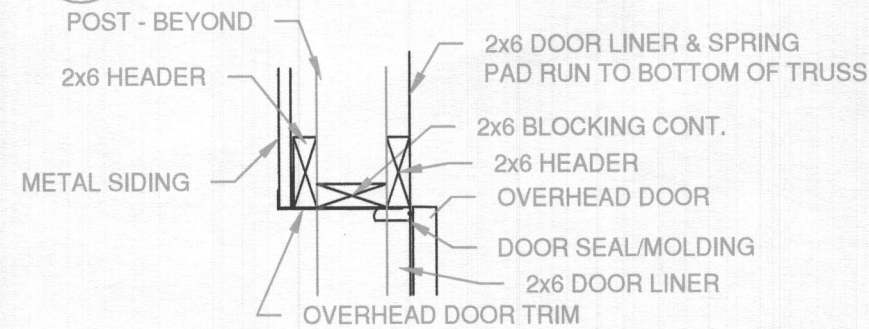

OD 1 O.H. DOOR HEADER DETAIL

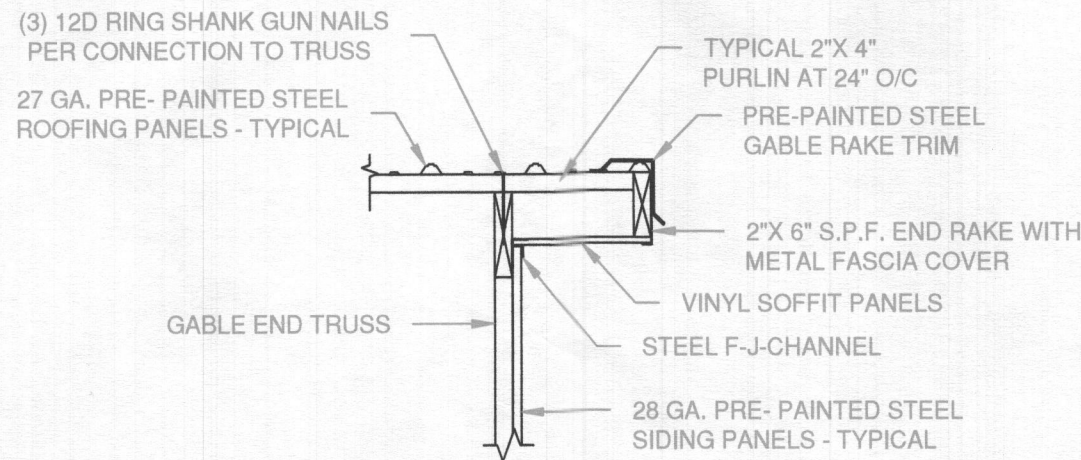

GO 1 TYPICAL GABLE OVERHANG DETAIL

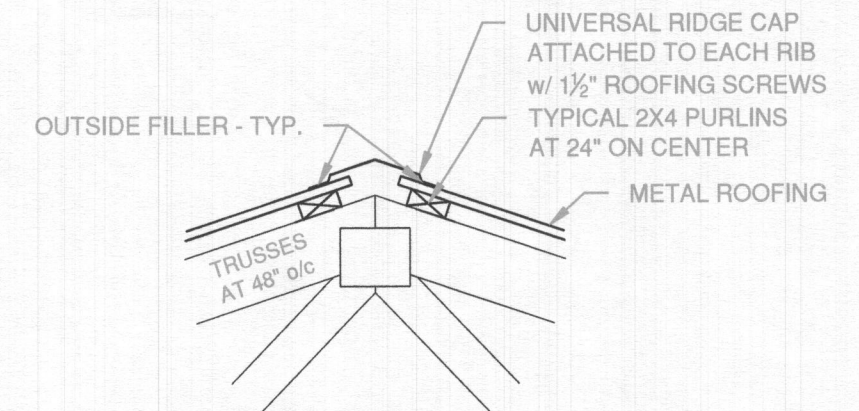

R 1 ROOF RIDGE DETAIL

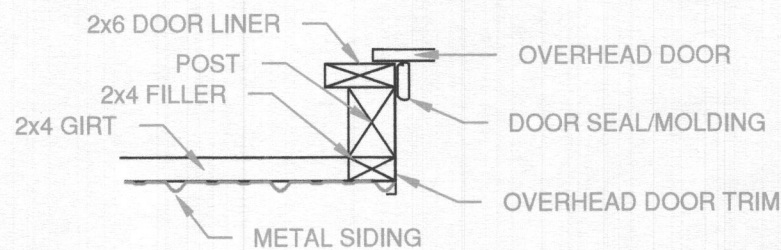

OD 2 O.H. DOOR JAMB DETAIL

Professional Certification.
I hereby certify that these documents were prepared or approved by me, and that I am a duly licensed professional engineer under the laws of the State of Maryland, License No. 16053, Expiration Date: 06-04-2024, per Code of Maryland Regulations 09.23.03.10



Revisions:	

BUILDING SIZE: 50x50x14'-3"	DATE: 06/15/2023	James A. Koppenhaver, P.E. 575 Van Reed Rd Wyomissing, PA 19610 484-794-9949 koppenhaverpe@gmail.com
DRAWN BY: JOHN DAY	Job Number:	
CHECKED BY:	PRICE-001	

PPB. Inc. Pioneer Pole Buildings, Inc. 716 South Rt. 183 Schuylkill Haven, PA 17972 1-888-448-2505 Toll Free	SHEET: Detail A
	JOB SITE ADDRESS: 899 THE OLD STATION COURT WOODBINE, MD 21797

CUSTOMER ADDRESS:
 PETER PRICE
 899 THE OLD STATION COURT
 WOODBINE, MD 21797
 H: 410-299-5933
 C: 410-299-9271

Professional Certification.
 I hereby certify that these documents were prepared or approved by me, and that I am a duly licensed professional engineer under the laws of the State of Maryland, License No. 16053, Expiration Date: 06-04-2024, per Code of Maryland Regulations 09.23.03.10

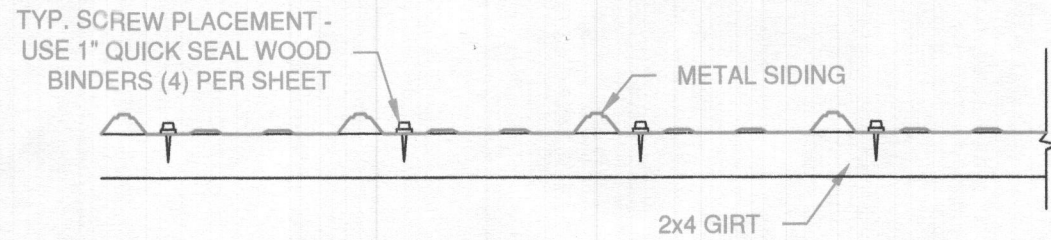

SS 1 SIDING SCREW PATTERN DETAIL

Fasten each header to post with (14) 12d nails Space nails to avoid splitting wood Overlap header onto beam 1' min with (14) 12d nails on each side of beam

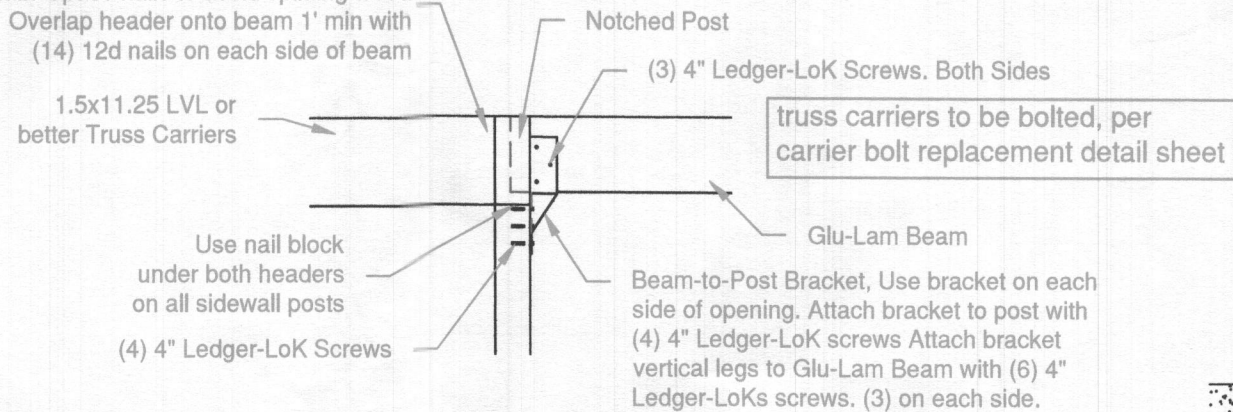

GLB 1 GLU-LAM BEAM ATTACHMENT

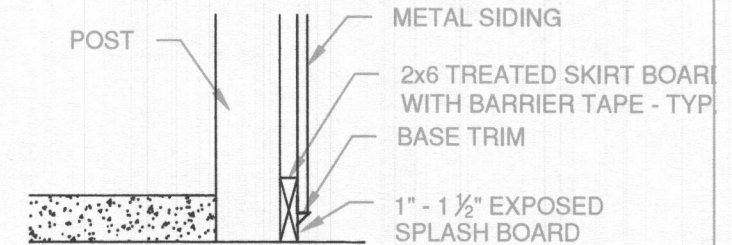

BT 1 BASE TRIM DETAIL

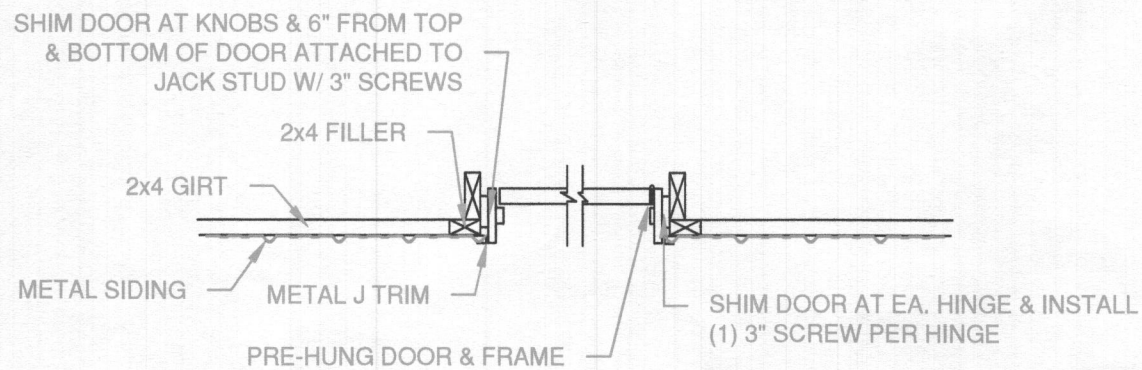

SD 2 SERVICE DOOR JAMB DETAIL

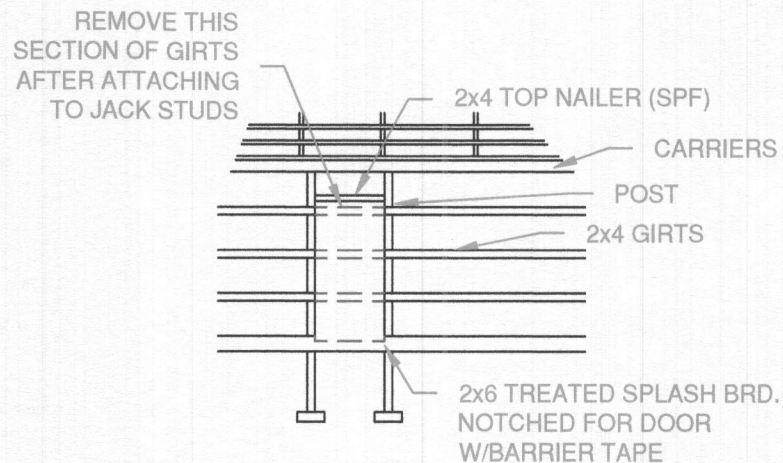

SD 1 SERVICE DOOR FRAMING DETAIL

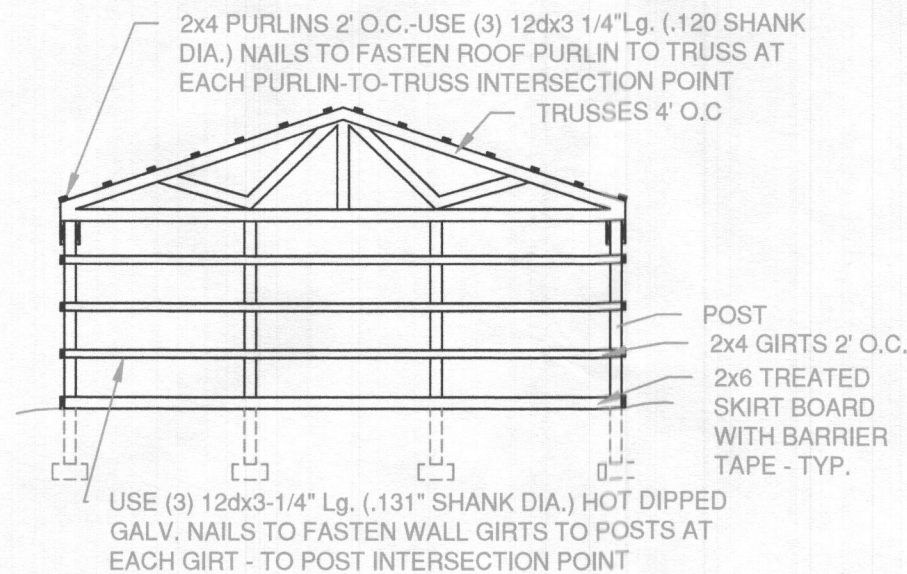

GF 1 GENERAL GABLE VIEW DETAIL

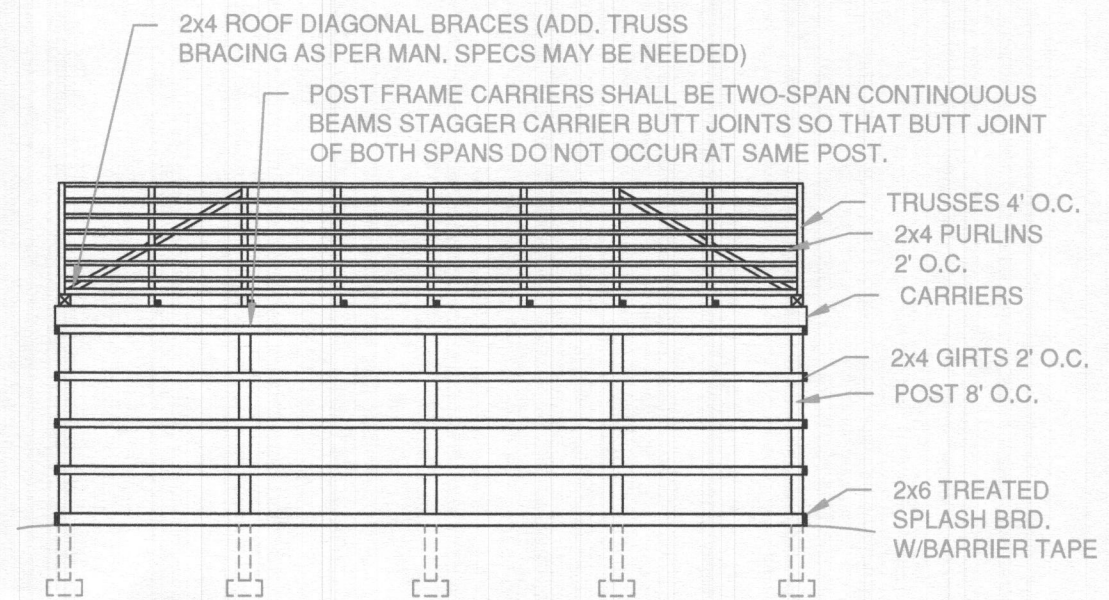

EF 1 GENERAL EAVE VIEW DETAIL

Revisions:

BUILDING SIZE: 50x50x14'-3"		DATE: 06/15/2023	James A. Koppenhaver, P.E. 575 Van Reed Rd Wyomissing, PA 19610 484-794-9949 koppenhaverpe@gmail.com
DRAWN BY: JOSH DAY	Job Number: PRICE-001	SHEET: Detail B	
CHECKED BY:			
PPB. Inc. Pioneer Pole Buildings, Inc. 716 South Rt. 183 Schuylkill Haven, PA 17972 1-888-448-2505 Toll Free		JOB SITE ADDRESS: 899 THE OLD STATION COURT WOODBINE, MD 21797	CUSTOMER ADDRESS: PETER PRICE 899 THE OLD STATION COURT WOODBINE, MD 21797 H: 410-299-5933 C: 410-299-9271

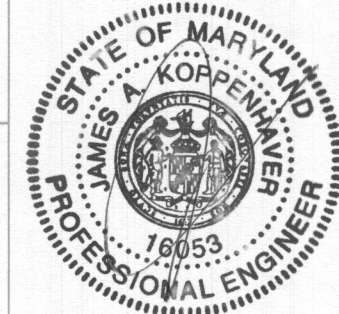

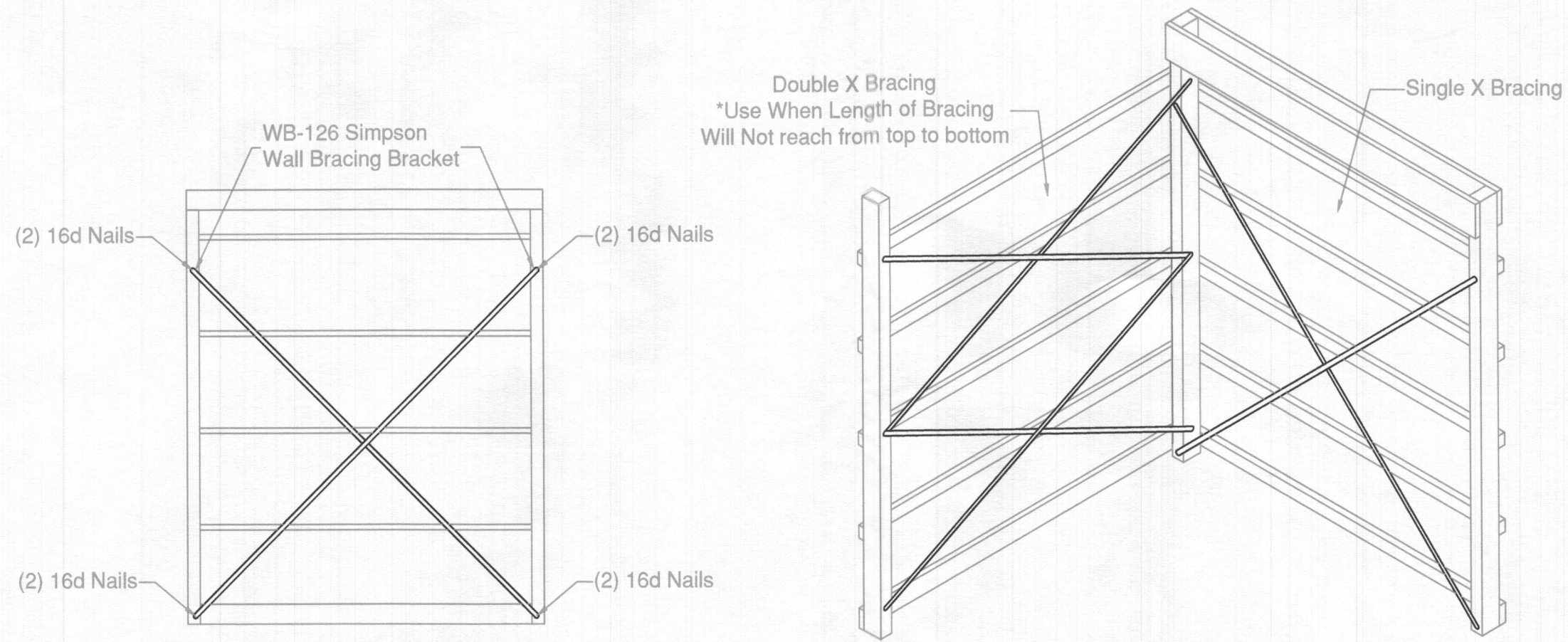

WB
1
DIAGONAL WALL BRACING DETAIL

Professional Certification.
I hereby certify that these documents were prepared or approved by me, and that I am a duly licensed professional engineer under the laws of the State of Maryland, License No. 16053, Expiration Date: 06-04-2024, per Code of Maryland Regulations 09.23.03.10

Revisions:	BUILDING SIZE: 50x50x14'-3"		DATE: 06/15/2023	James A. Koppenhaver, P.E. 575 Van Reed Rd Wyomissing, PA 19610 484-794-9949 koppenhaverpe@gmail.com
	DRAWN BY: JOSH DAY	Job Number: PRICE-001	SHEET: CARRIER BOLT REPLACEMENT	
	CHECKED BY:			
	PPB. Inc. Pioneer Pole Buildings, Inc. 716 South Rt. 183 Schuylkill Haven, PA 17972 1-888-448-2505 Toll Free		JOB SITE ADDRESS: 899 THE OLD STATION COURT WOODBINE, MD 21797	CUSTOMER ADDRESS: PETER PRICE 899 THE OLD STATION COURT WOODBINE, MD 21797 H: 410-299-5933 C: 410-299-9271
	ALL RIGHTS RESERVED BY PIONEER POLE BUILDINGS, INC. NOT TO BE COPIED OR REPRODUCED WITHOUT WRITTEN PERMISSION.			



General Notes:

Foundations:

- A. Bottom of all exterior footings shall be minimum of 5'-0" below finished grade. Minimum size 10" high x 24" round or as noted.
- B. Assumed design soil bearing pressure = 2,000 PSF U.N.O.
- C. Minimum concrete footing strength to be 3,500 PSI at 28 days.

Metal Cladding:

- A. Steel siding and roofing panels shall be fabricated from 27 # 28 gauge, grade e 180 KSI structural quality steel conforming to ASTM A-446 with a hot dipped galvanized coating conforming to ASTM A-525 or with an aluminum-zinc alloy coating conforming to ASTM A-792 (plain products only).
- B. Paint Finish: All panels when required shall receive a factory applied polyester coating conforming to the manufacturer's specifications.
- C. Flashings: All flashings shall be shop fabricated from material that is the same gauge and finish as the wall/roof panels to which they are attached.
- D. Closures: Shall be pre-molded neoprene to match the configuration of the wall/roof panel and shall be in lengths as supplied by the panel manufacturer.
- E. Fasteners: All screw fasteners shall have a combination steel and neoprene washer. Nails shall have a Fabriseal washer or equivalent. Fastener selection and installation shall be as recommended by the cladding manufacturer.

Wood Trusses:

- A. Trusses are to be designed and fabricated in accordance with the published standards of the National Forest Products Association and the Truss Plate Institute's "Design Specifications for Light, Metal Plate Connected Wood Trusses" (TPI-XX) Latest Edition.
- B. The web configuration plate sizes, chord sizes and lateral bracing shall be designed by a licensed professional engineer. The truss manufacturer shall provide the contractor with shop drawings of each truss design bearing the engineers seal. Shop drawings shall be approved by the contractor before fabrication.
- C. All trusses shall be designed for the loading, spacing and geometry shown on the plan.
- D. The contractor shall install the bracing of the wood trusses in accordance with the manufacturer's design. Minimum lateral bracing of web and bottom chord members shall be as required by truss design.

Lumber:

- A. All lumber shall comply to the requirements of the American Institute of Timber Construction and the National Forest Products Association's "National Design Specification for Wood Construction".
- B. All lumber for posts and beams shall be #2 or better southern yellow pine grade stamped by a SPIB approved mill, surfaced at a maximum moisture content of 19% treated .6 pcf ACQ, .23 pcf MCA or equal.
- C. All lumber for headers shall be SYP #1 or Better, grade stamped by a SPIB approved mill, surfaced at a maximum moisture content of 19%.
- D. All lumber exposed to ground contact or insect infestation shall be treated according to the American Wood preservers' Association Standards, .6 pcf ACQ, .15 pcf MCA or equal.

Connections:

- A. All wood connection to be made according to the "National Design Specification for Wood Construction". The minimum connection to be two 12 penny nails. Other connection as per plan or as controlled by standard construction practices.
- B. It is acceptable for 2x4 wind girt spacing to vary from 18" to 30", when the span of the girt is 10' or less. Horizontal spacing of fasteners for the metal wall panels shall be in accordance with the panel manufacturer's instructions. The wind girt spacing up to 30" conforms to the rigid diaphragm design for post frame walls.

Cautionary Notes:

1. Structural components such as posts, beams, trusses or fasteners and attachment brackets should NOT be modified, notched or cut in any manner without proper review and approval of the building design professional.
2. Rainwater and melt water should be directed away from post foundation locations.
3. On enclosed buildings with large doors (that is buildings designed as completely enclosed) the doors should be closed during periods high wind and/or stormy weather to reduce uplift forces on the building.
4. Do NOT lean heavy materials against posts or girts unless the building has been designed for those types of loads. Do NOT store loose material against walls unless building has been designed for side thrust loads and any moisture contained in the loose materials.
5. Do NOT use the roof trusses for storing material unless the building and roof trusses have been designed for those loads.
6. Concentrated loads such as ceiling-mounted furnaces, wet sprinkler systems, ventilation hoods, etc. SHALL NOT be attached to the roof trusses without the prior review and written approval of Pioneer Pole Buildings, Inc. and the building design professional.
7. Do NOT install hardware that would maintain snow cover on the roof of buildings.
8. Do NOT attach additional buildings or lean-to enclosed areas to pole barn buildings unless the building has been designed for the additional loads created by these building additions.
9. Door openings should NOT be added to the building walls after the building has been constructed without review and approval of the building design professional.

Misc. Notes:

These plans are designed in accordance with the 2018 IBC Construction Class VB IBC USE GROUP "U" UTILITY

TRUSS CARRIERS TO BE EQUAL TO OR BETTER THAN 1.5"X11.25" 2.OE LVL
 5"X15-1/8" GLU-LAM BEAM AT EAVE #1 16' OHD
 BOLTED HEADERS
 HOLD ALL DOORS +3" FOR CONCRETE FLOOR
 10"X24" CONCRETE FOOTERS MUST BE WET MIXED ON SITE BEFORE PLACING INTO FOOTING HOLE
 12" OVERHANGS ON EAVES AND GABLES
 MULLING KIT FOR WINDOW SETS
 DOUBLE BUBBLE VAPOR BARRIER BENEATH METAL ROOFING
 104 LIN. FT. 6K GUTTER W/ DOWNSPOUT
 CEILING LINER W/ R-38 INSULATION W/ INSULATED CEILING ACCESS DOOR
 INTERIOR WALL LINER W/ R21 INSULATION TO BE INSTALLED
 ZXL SCREWS TO BE UTILIZED ON ROOFING PANELS
 HURRICANE TIES USED = RT16A (USP CONNECTORS)
 UNIVERSAL RIDGE VENT

Professional Certification.
 I hereby certify that these documents were prepared or approved by me, and that I am a duly licensed professional engineer under the laws of the State of Maryland, License No. 16053, Expiration Date: 06-04-2024, per Code of Maryland Regulations 09.23.03.10

DESIGN CRITERIA:
Ground Snow Loads:
 Ground Snow Load (psf) = 40
Wind Speed:
 Wind Speed = 115 mph
Truss Loads:
 Top Chord Live (psf) = 35
 Top Chord Dead (psf) = 5
 Bottom Chord Live (psf) = 0
 Bottom Chord Dead (psf) = 10

Revisions:

BUILDING SIZE: 50x50x14'-3"		DATE: 06/15/2023	James A. Koppenhaver, P.E. 575 Van Reed Rd Wyomissing, PA 19610 484-794-9949 koppenhaverpe@gmail.com
DRAWN BY: JOSH DAY	Job Number: PRICE-001	SHEET: Notes	
CHECKED BY:			
PPB. Inc. Pioneer Pole Buildings, Inc. 716 South Rt. 183 Schuylkill Haven, PA 17972 1-888-448-2505 Toll Free		JOB SITE ADDRESS: 899 THE OLD STATION COURT WOODBINE, MD 21797	CUSTOMER ADDRESS: PETER PRICE 899 THE OLD STATION COURT WOODBINE, MD 21797 H: 410-299-5933 C: 410-299-9271

