

EAVE #2

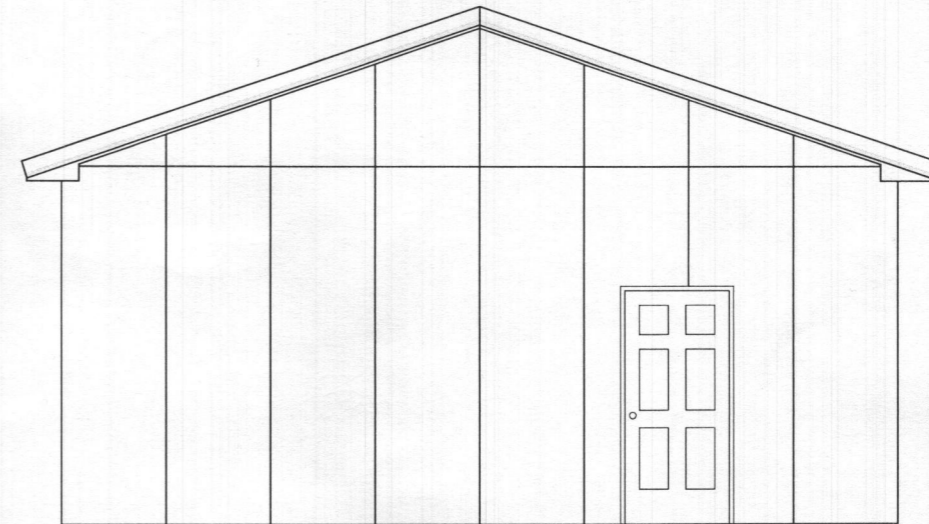

GABLE #2

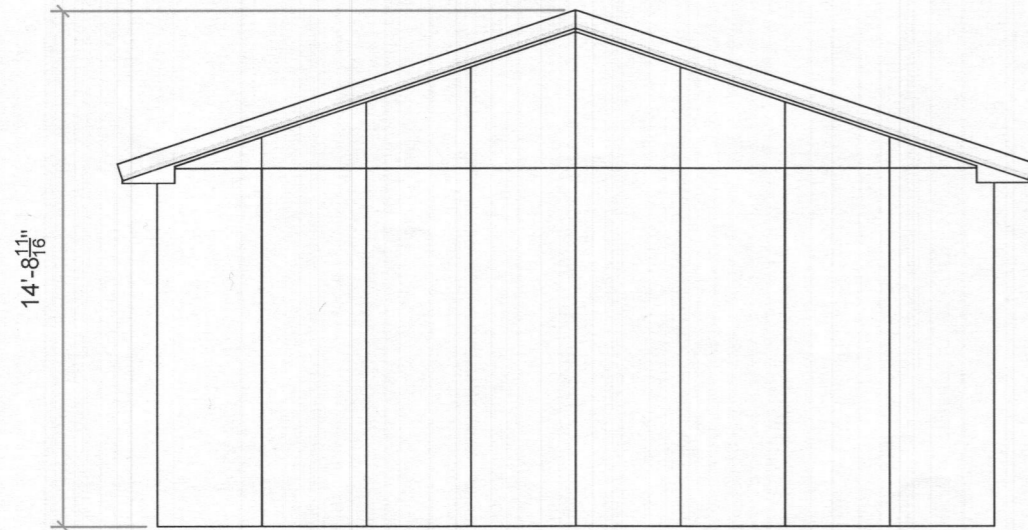

GABLE #1

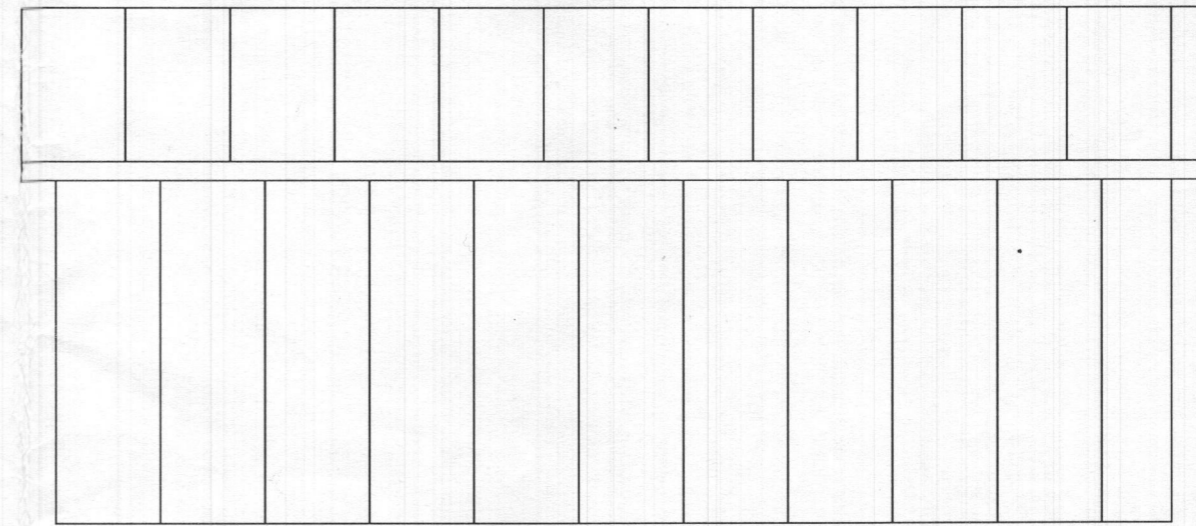

EAVE #1

Revisions:

BUILDING SIZE: 24x32x10'-4"

DATE: 7-7-2023

DRAWN BY: HEIDI KLOCK
CHECKED BY:

Job Number: KIRCHMAN-1

SHEET: Elevations

PPB. Inc.

Pioneer Pole Buildings, Inc.
716 South Rt. 183
Schuylkill Haven, PA 17972
1-888-448-2505 Toll Free

JOB SITE ADDRESS:
13881 TRIADELPHIA MILL RD
DAYTON, MD

CUSTOMER ADDRESS:
FRANK J. KIRCHMAN
VALERIE C. KIRCHMAN
6424 FAIREST DREAM LANE
COLUMBIA, MD 21044
301-908-8183 (H)
301-908-8184 (M)

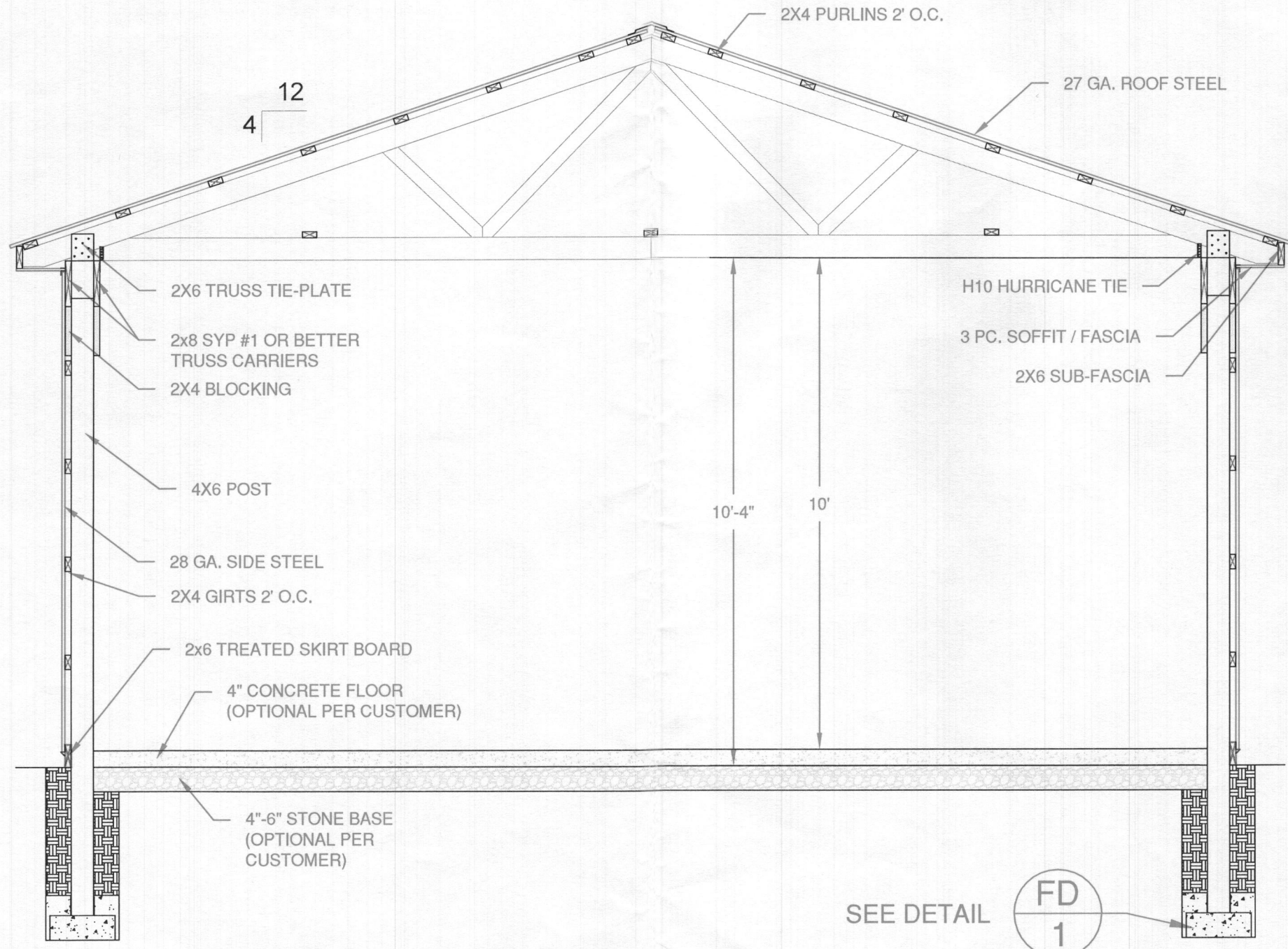

TYP. CROSS SECTION

Revisions:

BUILDING SIZE: 24x32x10'-4"		DATE: 7-7-2023
DRAWN BY: HEIDI KLOCK	Job Number: KIRCHMAN-1	SHEET: TYP
CHECKED BY:		Cross Section
PPB. Inc. Pioneer Pole Buildings, Inc. 716 South Rt. 183 Schuylkill Haven, PA 17972 1-888-448-2505 Toll Free		JOB SITE ADDRESS: 13881 TRIADELPHIA MILL RD DAYTON, MD
		CUSTOMER ADDRESS: FRANK J. KIRCHMAN VALERIE C. KIRCHMAN 6424 FAIREST DREAM LANE COLUMBIA, MD 21044 301-908-8183 (H) 301-908-8184 (M)

HOUSE

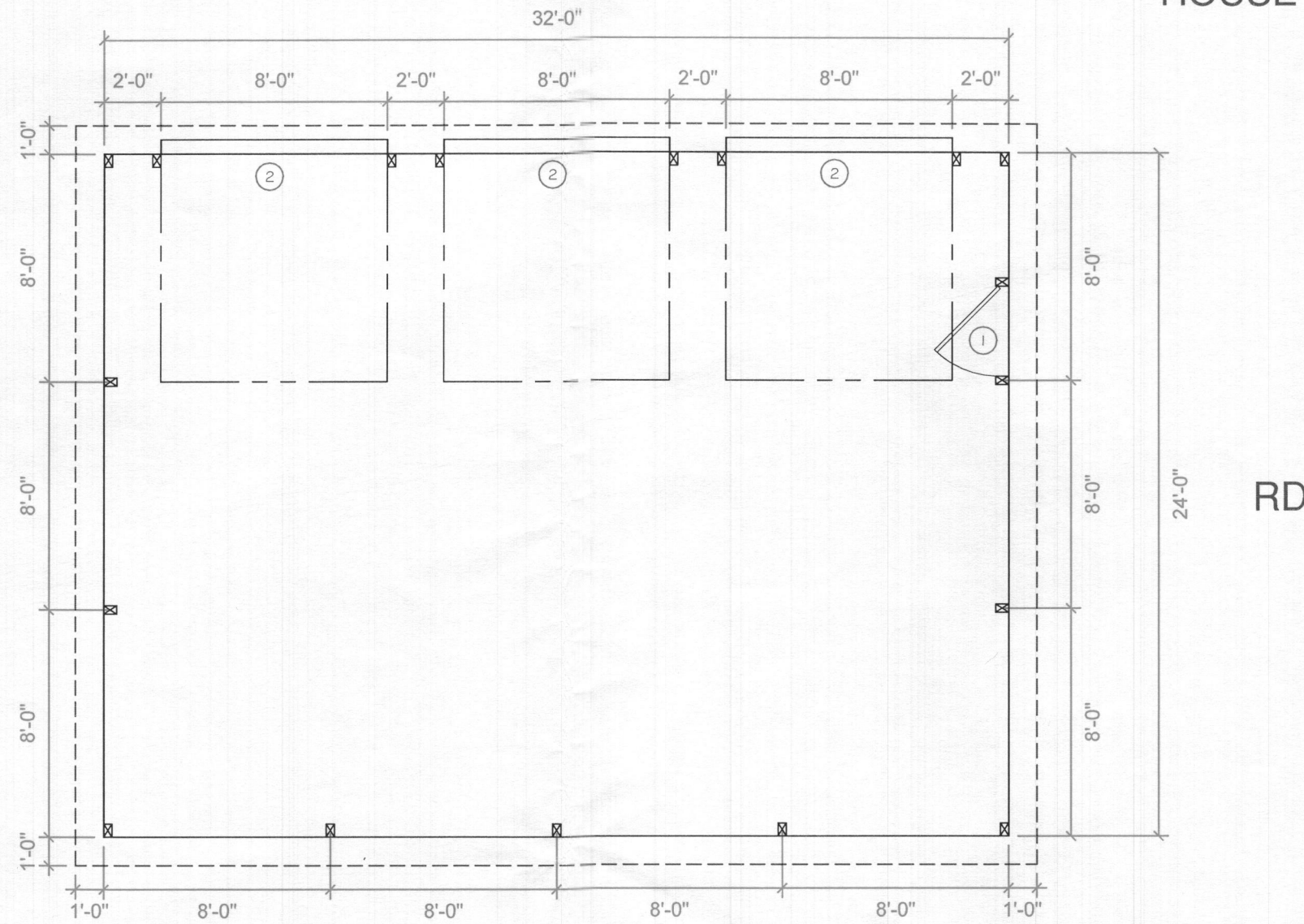
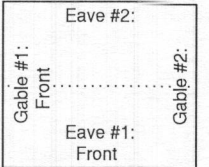

WINDOW & DOOR SCHEDULE

SYM	TYPE OF WINDOW / DOOR	NOMIN.	R.O.
①	ENTRY DOOR	3068	38" x 82½"
②	OVERHEAD DOOR	8x8	8'-0" x 8'-4"

Revisions:

BUILDING SIZE: 24x32x10'-4"

DATE: 7-7-2023

DRAWN BY: HEIDI KLOCK
CHECKED BY: KIRCHMAN-1

SHEET: Pole Plan

PPB. Inc.

Pioneer Pole Buildings, Inc.
716 South Rt. 183
Schuylkill Haven, PA 17972
1-888-448-2505 Toll Free

JOB SITE ADDRESS:
13881 TRIADDELPHIA MILL RD
DAYTON, MD

CUSTOMER ADDRESS:
FRANK J. KIRCHMAN
VALERIE C. KIRCHMAN
6424 FAIREST DREAM LANE
COLUMBIA, MD 21044
301-908-8183 (H)
301-908-8184 (M)

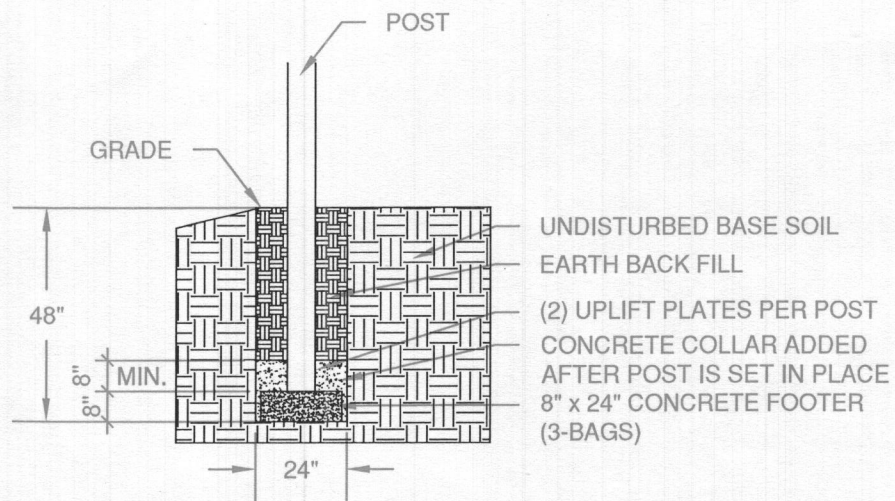

FD 1 FOOTER DETAIL

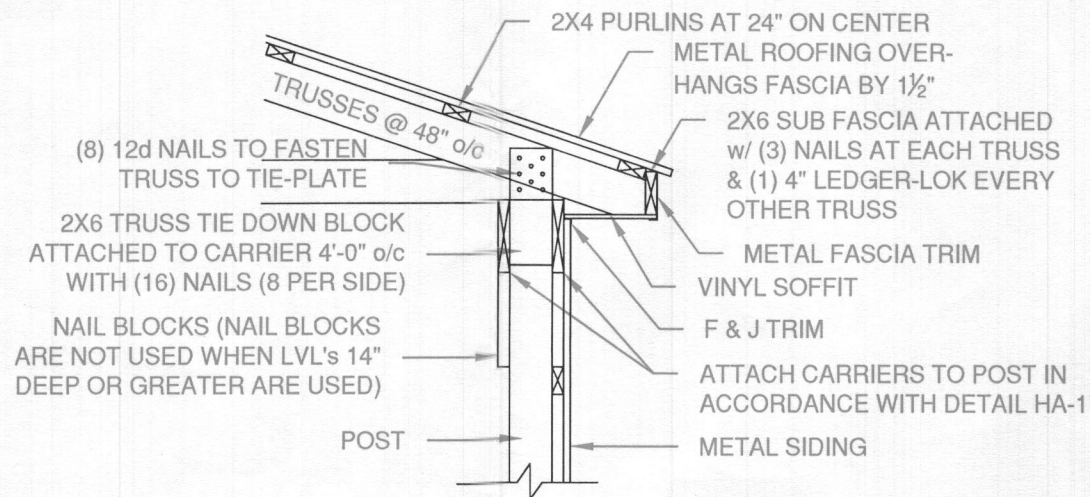

RE 3 ROOF EDGE DET.

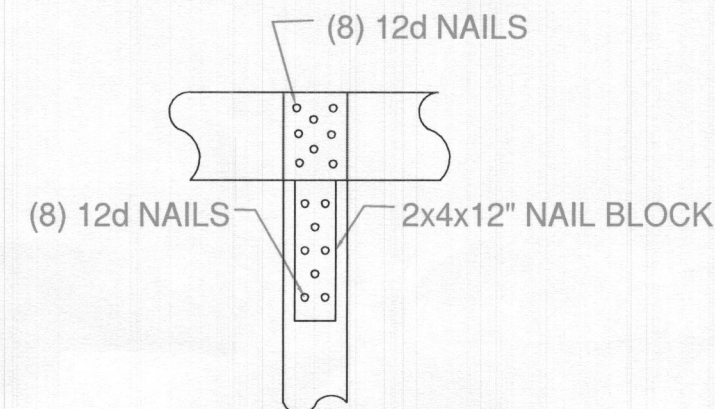

HA 1 2x8 SYP #1 OR BETTER HEADER ATTACHMENT

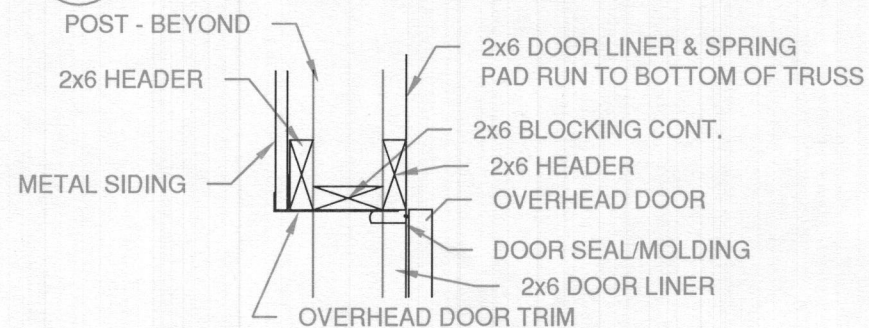

OD 1 O.H. DOOR HEADER DETAIL

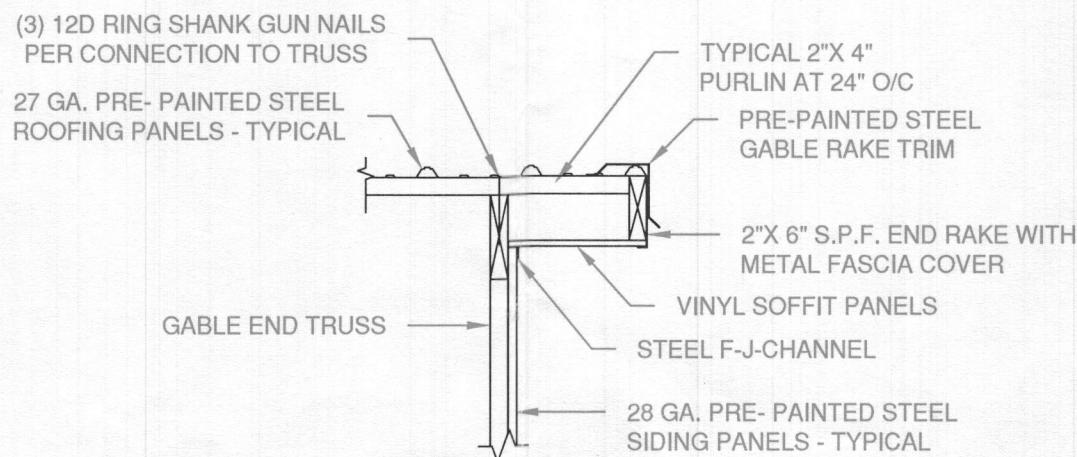

GO 1 TYPICAL GABLE OVERHANG DETAIL

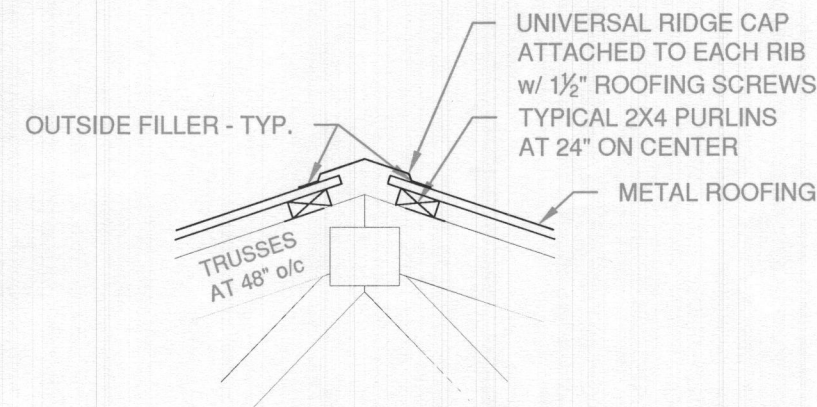

R 1 ROOF RIDGE DETAIL

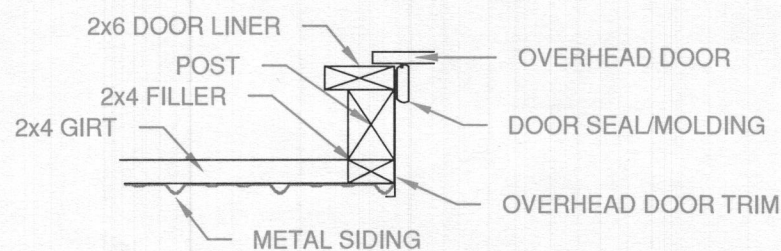

OD 2 O.H. DOOR JAMB DETAIL

Revisions:

BUILDING SIZE: 24x32x10'-4"

DATE: 7-7-2023

DRAWN BY: HEIDI KLOCK
CHECKED BY:

Job Number: KIRCHMAN-1

SHEET: Detail A

PPB. Inc.

Pioneer Pole Buildings, Inc.
716 South Rt. 183
Schuylkill Haven, PA 17972
1-888-448-2505 Toll Free

JOB SITE ADDRESS:
13881 TRIADELPHIA MILL RD
DAYTON, MD

CUSTOMER ADDRESS:
FRANK J. KIRCHMAN
VALERIE C. KIRCHMAN
6424 FAIREST DREAM LANE
COLUMBIA, MD 21044
301-908-8183 (H)
301-908-8184 (M)

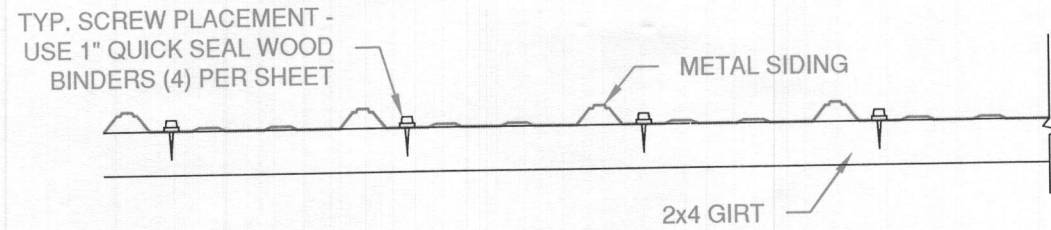

SS
1 SIDING SCREW PATTERN DETAIL

REMOVE THIS SECTION OF GIRTS AFTER ATTACHING TO JACK STUDS

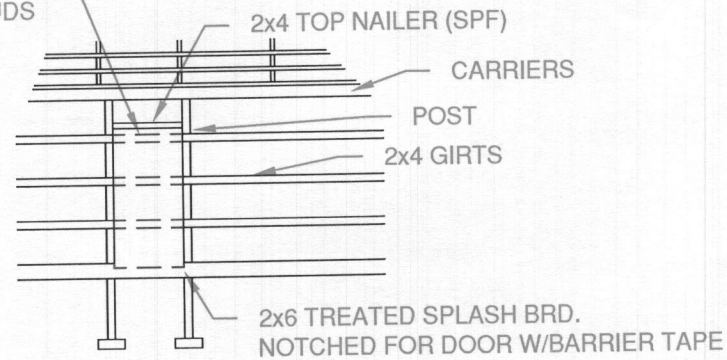

SD
1 SERVICE DOOR FRAMING DETAIL

SHIM DOOR AT KNOBS & 6" FROM TOP & BOTTOM OF DOOR ATTACHED TO JACK STUD W/ 3" SCREWS

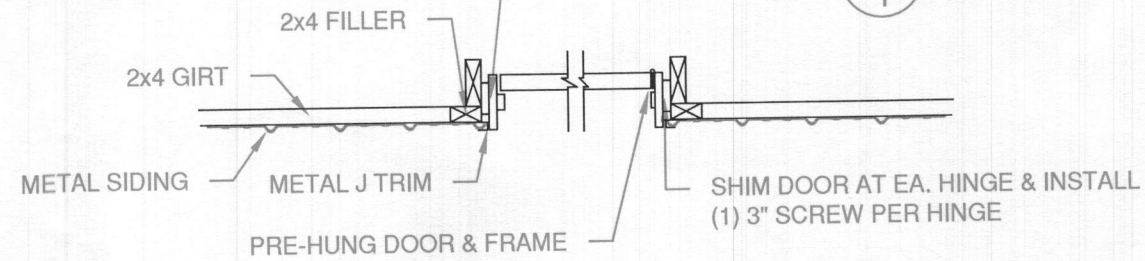

SD
2 SERVICE DOOR JAMB DETAIL

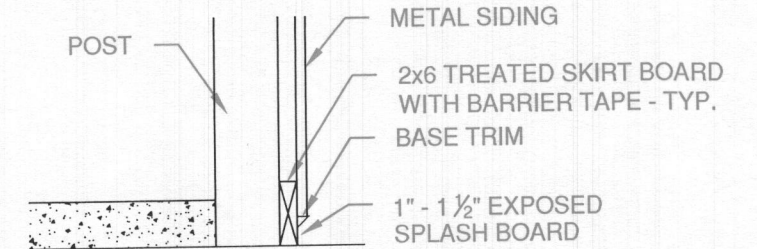

BT
1 BASE TRIM DETAIL

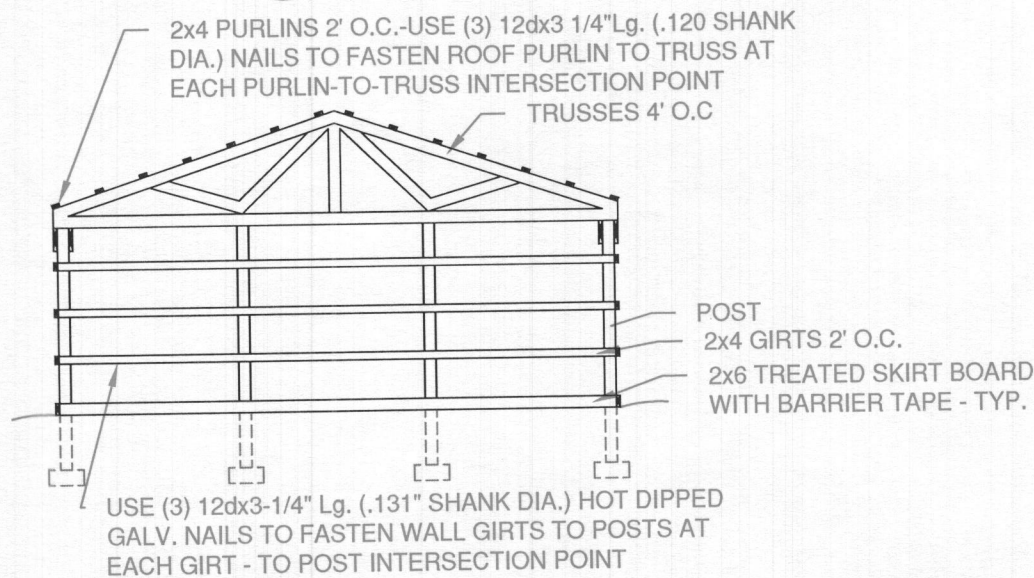

GF
1 GENERAL GABLE VIEW DETAIL

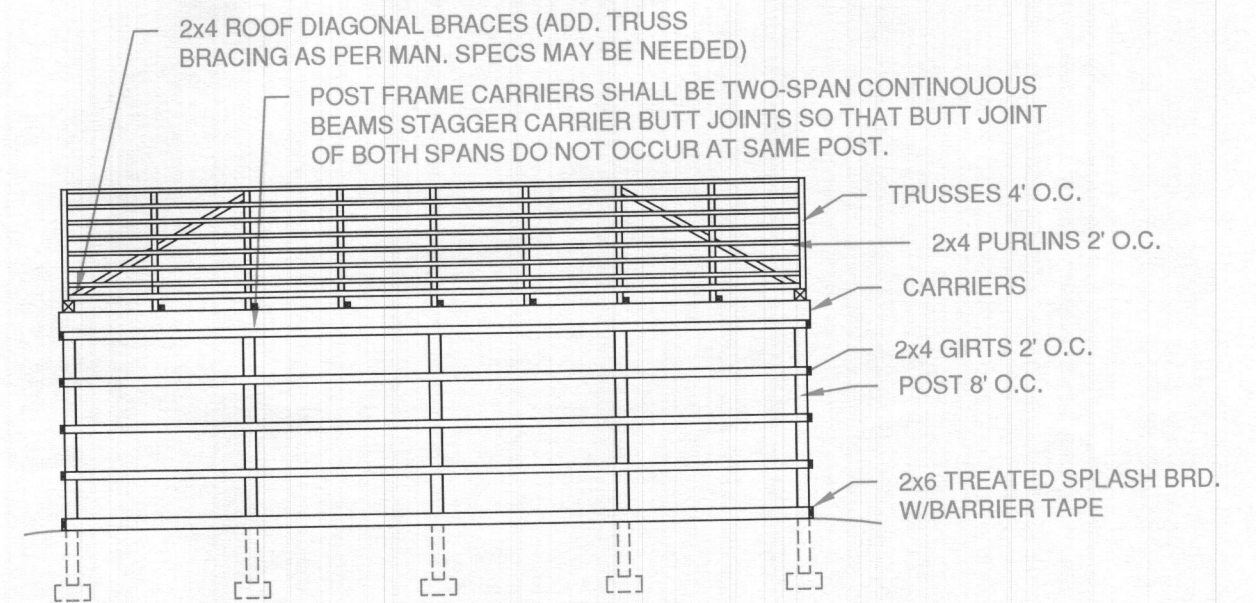

EF
1 GENERAL EAVE VIEW DETAIL

Revisions:

BUILDING SIZE: 24x32x10'-4"		DATE: 7-7-2023
DRAWN BY: HEIDI KLOCK	Job Number: KIRCHMAN-1	SHEET: Detail B
CHECKED BY:		
PPB. Inc. Pioneer Pole Buildings, Inc. 716 South Rt. 183 Schuylkill Haven, PA 17972 1-888-448-2505 Toll Free		JOB SITE ADDRESS: 13881 TRIADELPHIA MILL RD DAYTON, MD
		CUSTOMER ADDRESS: FRANK J. KIRCHMAN VALERIE C. KIRCHMAN 6424 FAIREST DREAM LANE COLUMBIA, MD 21044 301-908-8183 (H) 301-908-8184 (M)

General Notes:

Foundations:

- A. Bottom of all exterior footings shall be 48" below finished grade. Minimum size 8" high x 24" round or as noted.
- B. Assumed design soil bearing pressure = 2,000 PSF U.N.O.
- C. Minimum concrete footing strength to be 3,500 PSI at 28 days.

Metal Cladding:

- A. Steel siding and roofing panels shall be fabricated from 27 # 28 gauge, grade e 180 KSI structural quality steel conforming to ASTM A-446 with a hot dipped galvanized coating conforming to ASTM A-525 or with an aluminum-zinc alloy coating conforming to ASTM A-792 (plain products only).
- B. Paint Finish: All panels when required shall receive a factory applied polyester coating conforming to the manufacturer's specifications.
- C. Flashings: All flashings shall be shop fabricated from material that is the same gauge and finish as the wall/roof panels to which they are attached.
- D. Closures: Shall be pre-molded neoprene to match the configuration of the wall/roof panel and shall be in lengths as supplied by the panel manufacturer.
- E. Fasteners: All screw fasteners shall have a combination steel and neoprene washer. Nails shall have a Fabriseal washer or equivalent. Fastener selection and installation shall be as recommended by the cladding manufacturer.

Wood Trusses:

- A. Trusses are to be designed and fabricated in accordance with the published standards of the National Forest Products Association and the Truss Plate Institute's "Design Specifications for Light, Metal Plate Connected Wood Trusses" (TPI-XX) Latest Edition.
- B. The web configuration plate sizes, chord sizes and lateral bracing shall be designed by a licensed professional engineer. The truss manufacturer shall provide the contractor with shop drawings of each truss design bearing the engineers seal. Shop drawings shall be approved by the contractor before fabrication.
- C. All trusses shall be designed for the loading, spacing and geometry shown on the plan.
- D. The contractor shall install the bracing of the wood trusses in accordance with the manufacturer's design. Minimum lateral bracing of web and bottom chord members shall be as required by truss design.

Lumber:

- A. All lumber shall comply to the requirements of the American Institute of Timber Construction and the National Forest Products Association's "National Design Specification for Wood Construction".
- B. All lumber for posts and beams shall be #2 or better southern yellow pine grade stamped by a SPIB approved mill, surfaced at a maximum moisture content of 19% treated .6 pcf ACQ, .23 pcf MCA or equal.
- C. All lumber for headers shall be SYP #1 or Better, grade stamped by a SPIB approved mill, surfaced at a maximum moisture content of 19%.
- D. All lumber exposed to ground contact or insect infestation shall be treated according to the American Wood preservers' Association Standards, .6 pcf ACQ, .15 pcf MCA or equal.

Connections:

- A. All wood connection to be made according to the "National Design Specification for Wood Construction". The minimum connection to be two 12 penny nails. Other connection as per plan or as controlled by standard construction practices.
- B. It is acceptable for 2x4 wind girt spacing to vary from 18" to 30", when the span of the girt is 10' or less. Horizontal spacing of fasteners for the metal wall panels shall be in accordance with the panel manufacturer's instructions. The wind girt spacing up to 30" conforms to the rigid diaphragm design for post frame walls.

CONTRACT # 401619-005

Cautionary Notes:

- 1. Structural components such as posts, beams, trusses or fasteners and attachment brackets should NOT be modified, notched or cut in any manner without proper review and approval of the building design professional.
- 2. Rainwater and melt water should be directed away from post foundation locations.
- 3. On enclosed buildings with large doors (that is buildings designed as completely enclosed) the doors should be closed during periods high wind and/or stormy weather to reduce uplift forces on the building.
- 4. Do NOT lean heavy materials against posts or girts unless the building has been designed for those types of loads. Do NOT store loose material against walls unless building has been designed for side thrust loads and any moisture contained in the loose materials.
- 5. Do NOT use the roof trusses for storing material unless the building and roof trusses have been designed for those loads.
- 6. Concentrated loads such as ceiling-mounted furnaces, wet sprinkler systems, ventilation hoods, etc. SHALL NOT be attached to the roof trusses without the prior review and written approval of Pioneer Pole Buildings, Inc. and the building design professional.
- 7. Do NOT install hardware that would maintain snow cover on the roof of buildings.
- 8. Do NOT attach additional buildings or lean-to enclosed areas to pole barn buildings unless the building has been designed for the additional loads created by these building additions.
- 9. Door openings should NOT be added to the building walls after the building has been constructed without review and approval of the building design professional.

Misc. Notes:

These plans are designed in accordance with the 2018 IBC Construction Class VB

TRUSS CARRIERS USED TO BE EQUAL TO OR BETTER THAN 2x8 SYP #1

HURRICANE TIES USED = RT16A (USP CONNECTORS)
 UNIVERSAL RIDGE VENT
 IBC USE GROUP UTILITY

DESIGN CRITERIA:
Ground Snow Loads:
 Ground Snow Load (psf) = 40
Wind Speed:
 Wind Speed = 115 mph
Truss Loads:
 Top Chord Live (psf) = 40
 Top Chord Dead (psf) = 5
 Bottom Chord Live (psf) = 0
 Bottom Chord Dead (psf) = 5

Revisions:	BUILDING SIZE: 24x32x10'-4"		DATE: 7-7-2023	
	DRAWN BY: HEIDI KLOCK	Job Number: KIRCHMAN-1	SHEET: Notes	
	CHECKED BY:			
	PPB. Inc.		JOB SITE ADDRESS:	CUSTOMER ADDRESS:
	Pioneer Pole Buildings, Inc. 716 South Rt. 183 Schuylkill Haven, PA 17972 1-888-448-2505 Toll Free		13881 TRIADELPHIA MILL RD DAYTON, MD	FRANK J. KIRCHMAN VALERIE C. KIRCHMAN 6424 FAIREST DREAM LANE COLUMBIA, MD 21044 301-908-8183 (H) 301-908-8184 (M)
	ALL RIGHTS RESERVED BY PIONEER POLE BUILDINGS, INC. NOT TO BE COPIED OR REPRODUCED WITHOUT WRITTEN PERMISSION.			