

Bureau of Environmental Health

8930 Stanford Boulevard, Columbia, MD 21045

Main: 410-313-2640 | Fax: 410-313-2648

TDD 410-313-2323 | Toll Free 1-866-313-6300

www.hchealth.org

Facebook: www.facebook.com/hocohealth

Maura J. Rossman, M.D., Health Officer

RECEIPT DATE: 1/10/23 ONSITE SEWAGE DISPOSAL SYSTEM P 572742

APPROVAL DATE: 5/23/23 PERMIT: CONSTRUCTION A

PROPERTY ADDRESS: 7044 Colt Place

SUBDIVISION: W. Hallowshire LOT: 36 TAX ID:

CONTRACTOR: Fogles Septic Clean Inc EMAIL: km@foglesinc.com

CONTRACTOR ADDRESS: 580 Obrecht Rd, Sykesville, MD 21784 PHONE: 410.755.0670

CONTRACTOR CERTIFIED FOR BAT INSTALLATION: MDE MANUFACTURER:

PROPERTY OWNER: Tol Mid Atlantic EMAIL:

OWNER ADDRESS: 250 Gibraltar Rd Horsham PA PHONE: 410-872-9105

BAT UNIT MODEL: Norweco TMLP 750 PUMP SIZE: 1/3 PUMP TANK CAPACITY: 2,000

OPERATION & MAINTENANCE AGREEMENT DATE SIGNED: DATE RECORDED:

DISTRIBUTION SYSTEM: GRAVITY PRESSURE DOSED BEDROOMS: 6 APPLICATION RATE: 1.2

Table with trench specifications: LINEAR FEET REQUIRED: 140' (4@35'), INLET DEPTH: 1.5", TRENCH WIDTH: 3', MAXIMUM BOTTOM DEPTH: 6', MINIMUM SPACE BETWEEN TRENCHES: 10', EFFECTIVE AREA BEGINNING DEPTH: 3.5"

LOCATION: PER APPROVED SITE PLAN. SEWAGE DISPOSAL AREA AND BAT UNIT LOCATION MUST BE STAKED BY LICENSED SURVEYOR PRIOR TO PRE-CONSTRUCTION INSPECTION.

NOTES: BAT LPD DESIGN Need Pump, Alarm, BAT, and Electrical checks.

ISSUED BY: Z. Silvest ISSUE DATE: 2/9/23 EXPIRATION DATE: 2/9/24

- NOTE: CONTRACTOR MUST SCHEDULE A PRE-CONSTRUCTION INSPECTION PRIOR TO BEGINNING ANY INSTALLATION
NOTE: CONTRACTOR MUST SCHEDULE AN INSPECTION AND GAIN APPROVAL OF ALL COMPONENTS PRIOR TO COVERING
NOTE: STONE MUST BE APPROVED BY HEALTH DEPARTMENT AND GRAVEL TICKET MUST BE AVAILABLE FOR REVIEW.
NOTE: WATERTIGHT SEPTIC TANKS REQUIRED
NOTE: ALL PARTS OF SEPTIC SYSTEM SHALL BE AT LEAST 100 FEET DOWNGRADIENT FROM ANY WATER WELL
NOTE: MANHOLE RISERS REQUIRED ON ALL SEPTIC TANKS AND PUMP CHAMBERS
NOTE: AN ELECTRICAL PERMIT IS REQUIRED FOR INSTALLATION OF ANY ELECTRICAL COMPONENTS OF THE SYSTEM
NOTE: AN INDIVIDUAL CERTIFIED BY MDE AND THE MANUFACTURER FOR BAT INSTALLATION MUST BE PRESENT AT ALL TIMES DURING BAT INSTALLATION.
NOTE: MDE RECOMMENDS SEPTIC TANKS, BAT, AND OTHER PRETREATMENT UNITS BE PUMPED AT A FREQUENCY ADEQUATE TO ENSURE THAT SOLIDS ARE NOT DISCHARGED TO THE DISPOSAL AREA

NEITHER THE HOWARD COUNTY COUNCIL NOR THE HEALTH DEPARTMENT IS RESPONSIBLE FOR THE SUCCESSFUL OPERATION OF ANY SYSTEM. PERMITTEE RESPONSIBLE FOR OBTAINING FINAL APPROVAL ON THIS PERMIT. CALL 410-313-1771 TO SCHEDULE INSPECTIONS.

1"=40'

NOT TO SCALE

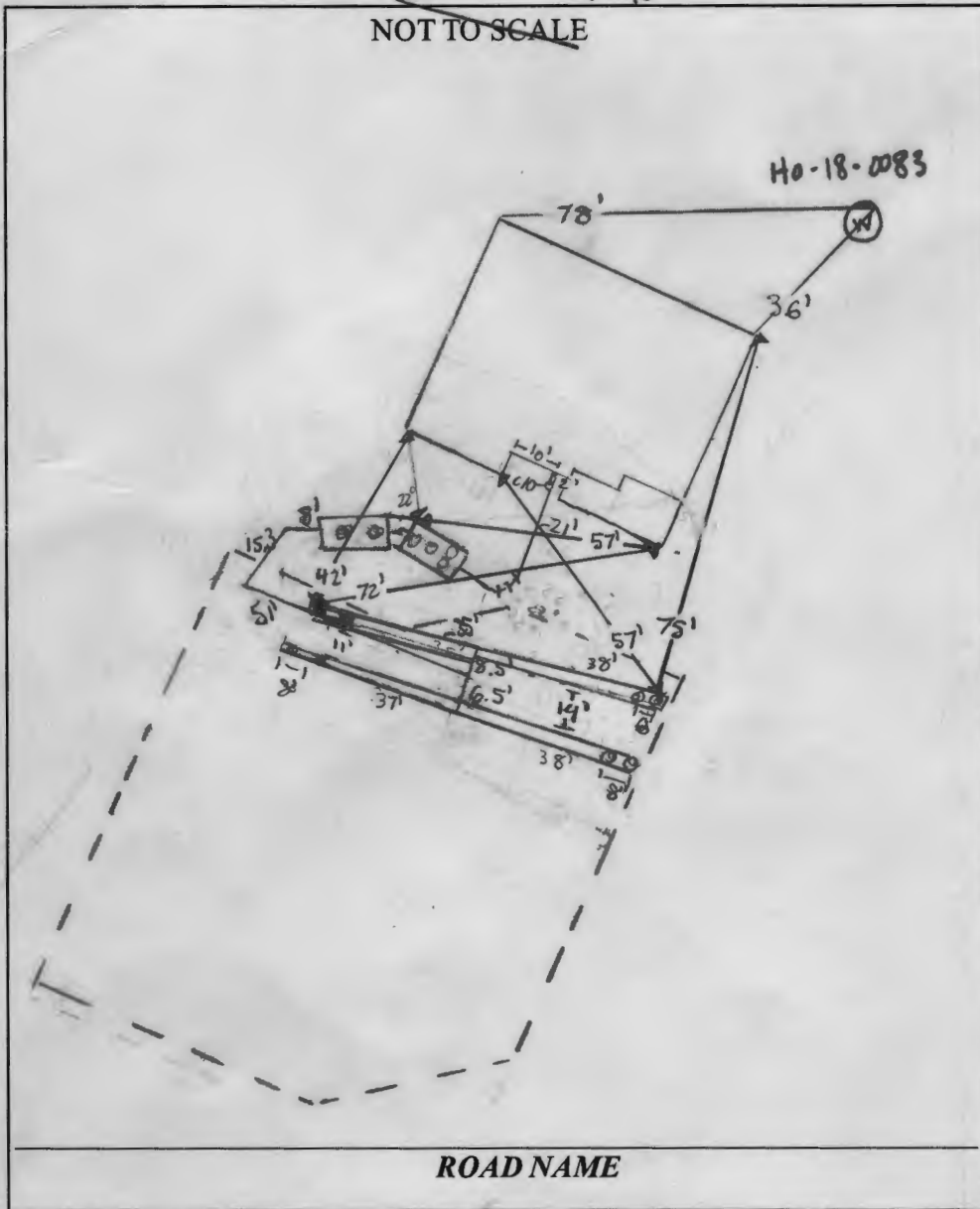

TRENCH/DRAINFIELD DATA		
WIDTH	INLET	BOTTOM
3'	1.5'	
NUMBER OF TRENCHES <u>4</u>		
TOTAL LENGTH <u>148</u>		
ABSORPTION AREA <u>444</u>		
DISTRIBUTION BOX LEVEL <u>—</u>		
DISTRIBUTION BOX BAFFLE <u>—</u>		
DISTRIBUTION BOX PORT <u>—</u>		

SEPTIC TANK DATA	
SEPTIC TANK 1 LEVEL	<u>yes</u>
MANUFACTURER	<u>Back River</u>
CAPACITY	<u>750</u> GAL
SEAM LOC	<u>Top</u>
TANK LID DEPTH	<u>2.5'-3'</u>
BAFFLES	<u>—</u>
BAFFLE FILTER	<u>—</u>
MANHOLE LOC	<u>Top Middle & Back</u>
6" PORT LOC	<u>—</u>
WATERTIGHT TEST	<u>—</u>
SLOTTED	<u>—</u>
DATE ON LID	<u>1/23/2023</u>
PUMP/SEPTIC TANK LEVEL	<u>yes</u>
MANUFACTURER	<u>B2 by lon</u>
CAPACITY	<u>2000</u> GAL
SEAM LOC	<u>Top</u>
TANK LID DEPTH	<u>2.5'-2'</u>
BAFFLES	<u>—</u>
BAFFLE FILTER	<u>—</u>
MANHOLE LOC	<u>front & back</u>
6" PORT LOC	<u>—</u>
WATERTIGHT TEST	<u>—</u>
SLOTTED	<u>—</u>
DATE ON LID	<u>1/12/23</u>

PRE-CONSTRUCTION:

2/13/23 - contractor on site w/ laser but upon arrival it was observed that approx. 1-4' of fill has been added on top of the SDA w/ tire ruts all over the area. Trench stakes were on top of a spoil pile 4' high, bring SDA back to original grade & have system restaked. Toll Brothers did not put any barrier around the SPA (RD)

2/27/2023 - Moved Tank slightly to be closer to location per plan. Elevation back to original. SD 2/28/2023 - T₁ & T₂ are 37". 1" off center on T₁ & 2" off center on T₂

INSTALLATION: 2/22/2023 - Installer ran CAT controller allowed them to set tank, but not do any work on tank or pipe connection yet (SB)

3/2/2023 - 260 RI pipe. Installer started upper trench. Trench inlet @ 2 instead of 1.5 added more so inlet @ 1.5 (SP)

3/31/2023 - upper lateral @ 31.06 lwr @ 30. Saw remaining trenches; T₁, T₂ & T₄ inlet & width per plan. Reinspect for P+A (SP)

5/16/2023 - Circuit panel for pump & Alarm outside of house. Audio & visual good. Turn ups need to be extended. T₃ @ 2' & T₄ @ 1.5. T₁ & T₂ good @ 2.5'. Need to do pump test (RD)

FINAL INSPECTOR S. Pae DATE OF APPROVAL 5/23/2023

5/23/2023 - Pump test successful. T₃ distal head @ 3' & T₄ @ 2.5' (SP)

7044 Colt + Place
Lot 36

preconstruction meeting on

2/13/23 →

1-4 feet of fill added

to the SDA - Stakes

knocked down by heavy

equipment running over SDA. (P)





Clerk of the Circuit Court for
Howard County

9250 Judicial Way,
Ellicott City, MD 21043
410-313-2111

LR - Agreement Recording Fee
1x 20.00 20.00

Name: kapur

Ref: 13 Lot 31 - 7020 Colt Pl.

LR - Agreement Surcharge
1x 40.00 40.00

LR - Agreement Recording Fee
1x 20.00 20.00

Name: chahalis

Ref: 14 Lot 36 - 7044 Colt Pl.

LR - Agreement Surcharge
1x 40.00 40.00

SubTotal: 120.00

Total: 120.00

CRD-Credit 120.00

Credit Card Confirmation : 013669

02/03/2023 10:40

CC13-LP

#16961115/497/4

Thank you for visiting us today~

Oswald, Hank

From: Oswald, Hank
Sent: Tuesday, January 17, 2023 10:56 AM
To: sriley1@tollbrothers.com
Cc: 'JIM@DECATURBUILDINGSERVICES.COM'; fogles.septic@gmail.com
Subject: O and M agreement_7044 Colt Place
Attachments: O&M agreement 4.23.18.pdf

Hi Ms. Riley:

Good morning. Fogle's came in on Friday (1/13/23) to pick-up the septic permit for 7044 Colt Place, but my coworker was not able to release the permit, because we don't have a signed/recorded Operation & Maintenance agreement. I've attached a copy of the agreement. Please complete this form, and bring it in to our office for signature prior to recording it with Land Records. We will need a copy of the receipt from Land Records prior to release of the septic permit.

Should you have any questions, please don't hesitate to ask.

Thanks,

Hank

Hank Oswald
Licensed Environmental Health Specialist
Bureau of Environmental Health
Howard County Health Department
8930 Stanford Blvd. Columbia, MD 21045
(410) 313 - 1786
www.hchealth.org

DISCLAIMER: This e-mail is intended only for the individual to whom it is addressed. It may be used only in accordance with applicable laws. If you are not the intended recipient, you are strictly prohibited from reading, disseminating, distributing, or copying this message. If you received this e-mail by mistake, please notify the sender and destroy this e-mail

LOT 36

Maura J. Rossman, M.D., Health Officer

**OPERATION AND MAINTENANCE AGREEMENT
FOR AN ON-SITE SEWAGE DISPOSAL SYSTEM
HAVING AN ADVANCED PRE-TREATMENT SYSTEM**

THIS AGREEMENT is made this 31st day of January, among Toll Brothers, George Chabalis, CM, hereinafter collectively referred to as "Owner", and the Howard County Health Department hereinafter referred to as the "County".

WHEREAS, Owner is the owner or contract owner of a parcel of land located at Lot 36, 7044 Curt Place, Dayton, MD 21036, in the 5th Election District of Howard County, Maryland, and the deed and subdivision plat of the property is recorded among the Land Records of Howard County, Maryland, Tax Map # 27, Block # 18, Parcel # 36, Deed Reference # 25500-09 and Tax Account # 603024 ("the Property").

WHEREAS, The Property is suitable for the installation of a conventional on-site sewage disposal system with an advanced pre-treatment system, utilizing best available technology to perform nitrogen reduction, in accordance with the Code of Maryland Regulations 26.04.02.07, effective November 24, 2016. The pre-treatment device being installed is Norweco Model TNTLP-750 GPD

NOW, THEREFORE, the parties hereto agree as follows:

A. Owner hereby grants to the County the right to enter upon the Property at any reasonable time with prior notice for access to the system to make periodic inspections and the Owner agrees to provide any information and data in Owner's possession reasonably requested and needed by the County.

B. Owner acknowledges and agrees that neither the County nor any of its agents or employees, either officially or individually, underwrites the operation of any system approved by them.

C. The Owner will devote reasonable care and effort to the operation and maintenance of the system in perpetuity or until a public sewer connection is made so that a system malfunction is not the result of poor maintenance, faulty operation, or neglect.

D. The Owner agrees to enter into a contract reasonably acceptable to the Owner and the County with a private entity to operate and maintain on a regularly scheduled basis an approved advanced pre-treatment system. The owner shall supply a copy of the contract to the County when it is renewed or altered.

E. This agreement shall run with the land and upon Owner's taking title to the Property shall bind the Owner, their heirs, successors, and assigns to the provisions of the agreement as long as

the property is in existence and after installation of the system. Owner further agrees that they shall inform in writing any subsequent purchaser or lessee of the Property that the system shall require maintenance or other attention. Upon taking title to the Property, the Owner agrees to cause this agreement to be recorded in the Land Records of Howard County and assure that it becomes part of the Deed for the subject property in order that prospective buyers may be aware of the special conditions affecting this property.

F. This agreement shall not be construed to limit any authority of the County to protect the public health, safety or comfort or to issue any other orders to take any other action which is now or may hereafter be within its authority.

G. This agreement may be voided at any time at the discretion of the County.

H. This agreement contains the entire agreement and understanding between the County and the Owner. There are no additional terms other than as contained in this agreement. This agreement may not be modified, except in writing signed by each of the parties or by their authorized representatives.

I. The laws of the State of Maryland govern the provisions of all transactions pursuant to this agreement.

J. Owner acknowledges and agrees that interior renovations to increase the number of bedrooms or an increase in living space shall not be permitted without approval from the County.

IN WITNESS WHEREOF, the parties have signed this agreement on the date indicated above.

William J. Owen 1/31/23
Howard County Health Department

[Signature] 1/31/23
Owner #1 Signature Date

George Chmela
Owner #1 Print Name

Owner#2 Signature Date

Owner #2 Print Name

Buyer #1 Signature Date

Buyer #1 Print Name

Buyer #2 Signature Date

Buyer #2 Print Name



BACK RIVER PRE-CAST, LLC
 PO BOX 329
 GLYNDON, MD 21071
 PH# 410-833-3394

NORWECO CERTIFICATION

PROPERTY OWNER: TOLL MID-ATLANTIC	INSTALLATION COMPANY: FOGLES SEPTIC
ADDRESS: 7044 COLT PLACE	CERTIFIED INSTALLER: JAMIE DEAVERS
CITY, ZIPCODE & COUNTY: DAYTON, 21036, HOWARD	PERMIT#
SIZE OF SYSTEM INSTALLED:	DATE INSTALLED: 02-28-23
750 GPD CONCRETE	START-UP DATE: 05-20-23
NUMBER OF BEDROOMS:	DATE OF FINAL INSPECTION:
TYPE OF INSTALLATION: NEW	DATE OF ELECTRICAL INSPECTION:
ELECTRICAL WIRING PER ELECTRICAL INSTRUCTIONS: YES	TANK LEVEL: YES
HT. OF CONTROL PANEL ABOVE FINAL GRADE: 48"	BURIAL DEPTH OF TANK: 30"
SYSTEM WIRED ON A 15-AMP DEDICATED CIRCUIT WITH STD. BREAKER: YES	RISERS 4" - 6" ABOVE GRADE: YES
LENGTH(S) OF UF WIRE PAST LAST AERATION RISER(S): 30"	VENTED LID(S) ON AERATION CHAMBER(S): YES
FEMALE PLUG(S) WIRED TO UF WIRE: YES	ANY GROUND SETTLING AROUND TANK:
CONDUIT(S) ENTERING AERATION RISER MADE WITH A WATERTIGHT CONNECTION: YES	NO
ISTHE INSIDE OF THE CONDUIT ENTERING THE CONTROL PANEL(S) AND AERATION RISER(S) SEALED WITH DUCT SEAL: YES	

ON 2ND PAGE MAKE A ROUGH SKETCH OF THE HOUSE ,WHERE THE SYSTEM IS LOCATED, WHERE THE CONTROL PANEL IS LOCATED , WHERE THE FRONT OF THE IS AND DIRECTIONS TO THE PROPERTY.

DIRECTIONS CAN START A FEW STREETS AWAY

EXAMPLE: RT. X LEFT ONTO XX STREET RIGHT ONTO PRIVATE DRIVEWAY 5TH HOUSE OF THE LEFT.

I certify that the Norweco Singlair TNT Wastewater Treatment System was installed according to the manufacture's specifications.

Matthew Geckle

May 20, 2023

Signature of BRP Representative

Vice-President

Date

RECEIPT

Howard County, MD
HOWARD COUNTY HEALTH DEPARTMENT
ASCEND ONE BUILDING
Columbia, MD 21045
8930 STANFORD BLVD

Application: WS-SP-APP-23-00007
Application Type: EnvHealth/Well and Septic/Sewage Disposal System/Application
Address: 7044 Colt PL,

Receipt No.	5600					
Payment Method	Ref Number	Amount Paid	Payment Date	Cashier ID	Received	Comments
Check	78345	\$396.00	01/11/2023	JUKING		Receipt # 72742

Work Description: Septic Permit