

FILE INQUIRY NOTES

10408 Guilford Rd + 10416 Guilford Rd

DATE	RESULTS OF REVIEW FOR FILE
2/25/21	Met with Kevin Bull (MDE), Kenny Santos (owner) and
	"Todd" (real estate developer).
	Owner says that runoff from 10390 Guilford Rd kept flooding his two properties (10408 and 10416) and creating an emergency situation - the tanks needed to be pumped every month week and kept overflowing.
	Mr. Santos and Todd removed the old tanks, which were made of concrete ^{concrete} and had cracks. They replaced them with plastic tanks in the same location - 1250 gal for 10408 and 1500 gal for 10416. For 10408, the tank was connected to an existing d-box, with unknown SDA. The 10416 tank is simply a holding tank, connected to nothing. This work was completed at the same time as SWM work by Todd and Santos to reroute the stream runoff.
	They say that because of snow, they weren't able to complete the septic work and didn't install risers, cleanouts or alarms yet. Santos says he has a contract with Fogles to have the tanks pumped every month.
	Santos submitted an application to connect his other property, 10412 10412 Guilford to public sewer in 2018 but has not received a response.
	Santos says he has only owned 10408 for a year, although

this is not shown on sdat (different owner). (ST)

2/25/21 Santos says well at 10416 is not in use. (ST)

FILE INQUIRY NOTES

10408 + 10416 Guilford Rd

DATE	RESULTS OF REVIEW FOR FILE
7/19/21	No effluent at grade for either property. (ST)
7/27/21	" (ST) 8/2/21 " (ST)
8/9/21	" (ST) 8/16/21 " (ST) 8/30/21 " (ST) 9/8/21 " (ST)
9/16/21	" (ST)
9/21/21	Sewage at grade behind 10416, around the second lid of the tank. Call Kenny Santos ^{cell} (240-882-8144) to inform him of the situation. He agreed to have the tank pumped tomorrow and have hydrated line sprinkled on the wet areas. Will reinspect tomorrow to observe outcome. (ST)
9/22/21	Both tanks pumped. Hydrated line sprinkled over area around ^{2nd} tank lid at 10416 Guilford. Sent email to Mr. Santos reminding that sewage cannot emerge to grade, and recommending more frequent pumping. (ST)
9/28/21	No effluent at grade for either property. (ST)
10/4/21	" (ST) 10/13/21 " (ST)
10/18/21	No effluent at grade for 10408. Sewage overflow at 10416 Guilford Rd, coming out of 2nd riser. Actual flow liquid flow flowing downhill into depressed spots. Affected area is triangle of 31' x 33' x 38' (see diagram below:)

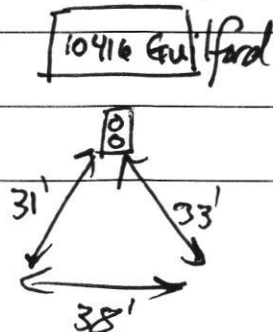

FILE INQUIRY NOTES

10408 + 10416 Guilford Rd

page 5 of 7

DATE	RESULTS OF REVIEW FOR FILE
10/18/21	(cont.) Contacted owner by cell phone and told him to pump and treat affected areas w/ hydrated lime immediately. See attached email for summary of phone conversation.
10/19/21	10416 Guilford sewage overflow was cleaned up and hydrated lime spread on affected area. (ST)
10/26/21	No sewage at grade for either property. (ST)
11/4/21	" (ST) 11/8/21 ST " (ST)
11/19/21	No sewage to grade was observed around holding tanks or yard; smell of sewage at 10416 Guilford. P
11/29/21	No sewage at grade for either property. (ST)
12/6/21	" (ST) 12/17/21 " (ST) 12/23/21 " (ST)
12/28/21	" (ST) 1/5/22 " (ST) 1/10/22 " (ST)
1/19/22	" (ST) 1/26/22 " (ST) 1/31/22 " (ST)
2/7/22	" (ST) 2/14/22 " (ST) 2/23/22 " (ST)
3/1/22	" (ST) 3/7/22 " (ST) 3/15/22 " (ST)
3/21/22	" (ST) 3/28/22 No sewage at grade for either property, port-a-potty from Gotingo set up behind 10416 Guilford Rd. (ST)
4/4/22	No sewage at grade for either property
4/11/22	" (ST) 4/18/22 " (ST) 4/25/22 " (ST) 5/2/22 " (ST)

Thomas, Susan

From: Gibson, George
Sent: Monday, April 12, 2021 11:16 AM
To: Gogolski, Maury
Cc: Davis, Daniel
Subject: RE: 10408, 10412, 10416 Guilford Road Sewer connections

Okay thanks.

From: Gogolski, Maury <mgogolski@howardcountymd.gov>
Sent: Monday, April 12, 2021 11:04 AM
To: Gibson, George <GGibson@howardcountymd.gov>
Cc: Davis, Daniel <ddavis@howardcountymd.gov>
Subject: FW: 10408, 10412, 10416 Guilford Road Sewer connections

Hey George,
As a heads up, this project will be coming down the pipeline as DA plan through Pdox instead of an ADO. See highlighted emails below.
Maury

From: Beschner, Ross <rbeschner@howardcountymd.gov>
Sent: Monday, April 12, 2021 10:35 AM
To: Gogolski, Maury <mgJustogolski@howardcountymd.gov>
Cc: John Heinrichs <jheinrichs@baylandinc.com>
Subject: RE: 10408, 10412, 10416 Guilford Road Sewer connections

Maury:

The proposed work definitely falls under a Developer Agreement (DA).

Thanks,
Ross A. Beschner, P.E.
Deputy Chief, Bureau of Utilities
Howard County Department of Public Works
Tel: 410-313-4974
Cell: 301-633-8831
rbeschner@howardcountymd.gov

From: Gogolski, Maury <mgogolski@howardcountymd.gov>
Sent: Monday, April 12, 2021 10:09 AM
To: John Heinrichs <jheinrichs@baylandinc.com>
Cc: Beschner, Ross <rbeschner@howardcountymd.gov>
Subject: RE: 10408, 10412, 10416 Guilford Road Sewer connections

Hi John,
I'm investigating your inquiry for public sewer extension for properties along Guilford Road. The attached exhibit you provided shows a conceptual sewer design, but is not dimensioned. Please provide total length of public sewer pipe,

including house connections. From my estimation, total length of pipe per Red markup is well over 200 LF, with significance being the public sewer extension exceeds ADO construction limit for total pipe length. Therefore, you will need to go through the Developer Agreement (DA) process for this Public Sewer Extension. Otherwise, please let me know if you worked out a design option with Ross to do an ADO. Ross is cc'd to this email.

Further DA process information provided upon request.

Thanks,
Maury

Maury Gogolski
Engineering Specialist II
Department of Planning and Zoning
Development Engineering Division
410-313-2360
3430 Court House Drive
Ellicott City, Maryland 21043

From: Davis, Daniel <ddavis@howardcountymd.gov>
Sent: Saturday, April 10, 2021 10:01 AM
To: Gogolski, Maury <mgogolski@howardcountymd.gov>; Gibson, George <GGibson@howardcountymd.gov>
Subject: FW: 10408, 10412, 10416 Guilford Road Sewer connections

Maury | George

Here is the attachment provided by Mr. Heinrichs that explains the location and situation he is attempting to resolve.

-daniel

Daniel L. Davis, P.E.
Chief - Bureau of Engineering | Utility Design Division

From: John Heinrichs <jheinrichs@baylandinc.com>
Sent: Tuesday, April 6, 2021 6:27 PM
To: Davis, Daniel <ddavis@howardcountymd.gov>
Cc: Hooe, Roy <RHooe@howardcountymd.gov>; Beschner, Ross <rbeschner@howardcountymd.gov>
Subject: RE: 10408, 10412, 10416 Guilford Road Sewer connections

[Note: This email originated from outside of the organization. Please only click on links or attachments if you know the sender.]

Hello Daniel,

Mr. Santos has engaged BayLand to design public sewer connections to four existing structures at the above addresses. The Health Department has determined that the existing septic systems are failing.

He also would like to provide a public water connection to 10416 Guilford Ave. I assume that the existing house is on a well. I prepared a concept sketch for proposed gravity sewer and it is attached.

I have a few questions regarding the design.

- The proposed shared gravity sewer line will be around 400 feet long. Do the ADO procedures still apply?
- Does the shared sewer main have to be public or can it remain private in a private utility easement?
- The rear portion of the property is very flat and there will not be a lot of cover on the new sewer. The first run of pipe and house connection will have to be set at minimum grades. Since the existing main is a 16" sewer it will likely surcharge the new line during peak flows. Can you give me some direction with regard to where the minimum tie-in invert elevation should be? Midpoint of the existing pipe? Crown of existing pipe?

- Does the County have a favored backflow prevention device?
- Is Amy Hart still the contact to obtain recently approved similar drawings to use as a guide? This would help reduce review comments and speed up review.
- Who would be my main contact at your office for further questions regarding the design?

Thank you for your help in getting this started correctly.

John

John Heinrichs, PE
Project Manager



BayLand Consultants & Designers, Inc.
7455 New Ridge Road, Suite T • Hanover, MD 21076

☎ 410.694.9401 Main
📱 410.961.2790 Mobile
✉ jheinrichs@baylandinc.com
🌐 www.baylandinc.com

From: Beschner, Ross <rbeschner@howardcountymd.gov>
Sent: Monday, April 05, 2021 11:54 AM
To: John Heinrichs <jheinrichs@baylandinc.com>
Cc: Davis, Daniel <ddavis@howardcountymd.gov>; Hooe, Roy <RHooe@howardcountymd.gov>
Subject: FW: 10408, 10412, 10416 Guilford Road Sewer connections

John:

As we discussed in our phone conversation today, since there is a viable gravity sewer option, a grinder pump system option is not acceptable. A tie-in to the sewer to the west (Contract No. S-321) and a public sanitary sewer main extension is required. There would also be a need to provide a public right-of-way for the public sanitary sewer main extension. Please coordinate with Daniel David in the Bureau of Utilities who is copied on this email.

Thanks,
Ross A. Beschner, P.E.
Deputy Chief, Bureau of Utilities
Howard County Department of Public Works
Tel: 410-313-4974
Cell: 301-633-8831
rbeschner@howardcountymd.gov

From: John Heinrichs <jheinrichs@baylandinc.com>
Sent: Thursday, April 1, 2021 10:28 AM
To: Hart, Amy <AHart@howardcountymd.gov>
Cc: Hooe, Roy <RHooe@howardcountymd.gov>
Subject: FW: 10408, 10412, 10416 Guilford Road Sewer connections

[Note: This email originated from outside of the organization. Please only click on links or attachments if you know the sender.]

Amy,
Roy Hooe referred me to you, see chain below. We have a client who owns 3 properties on Guilford Road in Jessup. The septic systems on the properties have failed or are failing. The Health Department has contacted him and requested that he resolve this problem as soon as possible. The properties are 10408, 10412, and 10416 Guilford Road. The owner contacted Mr. Hooe to begin the process of connecting to the public sewer in Guilford Road.

As the existing public gravity sewer is on the opposite side of Guilford Road, and the topography falls away from Guilford Road, gravity connections for the three properties is not possible. Mr. Hooe recommended using grinder pumps. Please see the concept plan attached. This plan will involve using a shared private low pressure system to pump the waste up to a transition manhole in the Guilford road right of way. From there it would flow by gravity under the paved roadway and tie into a new manhole placed on the existing sewer main.

Mr. Hooe indicated that you may be able to provide a sample drawing of a recent similar system constructed under the ADO procedure. This could be very helpful in expediting my design of proposed sewer system and the review at the Bureau of Utilities; so that the owner can begin construction as soon as possible.

Let me know if you can help me out with some recent sample plans. I am happy to come pick up paper copies if digital files are not available.

Thanks, John

John Heinrichs, PE
Project Manager



BayLand Consultants & Designers, Inc.
7455 New Ridge Road, Suite T • Hanover, MD 21076

☎ 410.694.9401 Main
📱 410.961.2790 Mobile
✉ jheinrichs@baylandinc.com
🌐 www.baylandinc.com

From: Hooe, Roy <RHooe@howardcountymd.gov>
Sent: Thursday, April 01, 2021 8:02 AM
To: John Heinrichs <jheinrichs@baylandinc.com>
Subject: RE: 10408, 10412, 10416 Guilford Road Sewer connections

Reach out to Amy Hart, she would have more requirements at ahart@howardcountymd.gov or 410-313-2723

From: John Heinrichs <jheinrichs@baylandinc.com>
Sent: Tuesday, March 30, 2021 3:20 PM
To: Hooe, Roy <RHooe@howardcountymd.gov>
Subject: RE: 10408, 10412, 10416 Guilford Road Sewer connections

[Note: This email originated from outside of the organization. Please only click on links or attachments if you know the sender.]

Roy,
Can you send me a copy of a recently approved similar set of ADO plans with grinder pumps to speed up our preparation and review time?
Thanks, John

John Heinrichs, P.E.



From: Hooe, Roy <RHooe@howardcountymd.gov>
Sent: Tuesday, March 30, 2021 7:30 AM

To: John Heinrichs <jheinrichs@baylandinc.com>
Subject: RE: 10408, 10412, 10416 Guilford Road Sewer connections

After you get everything you have to submit the ADO process.

Thanks
Roy Hooe

From: John Heinrichs <jheinrichs@baylandinc.com>
Sent: Friday, March 26, 2021 3:10 PM
To: Hooe, Roy <RHooe@howardcountymd.gov>
Subject: RE: 10408, 10412, 10416 Guilford Road Sewer connections

[Note: This email originated from outside of the organization. Please only click on links or attachments if you know the sender.]

Roy,
Thanks for the information. Looks like I will be moving forward with the design.
I have attached a sketch of the systems we are thinking of for your review.
Thanks again for your help.
John

John Heinrichs, P.E.



From: Hooe, Roy <RHooe@howardcountymd.gov>
Sent: Thursday, March 25, 2021 2:04 PM
To: John Heinrichs <jheinrichs@baylandinc.com>
Cc: Keith Tate <ktate@baylandinc.com>
Subject: RE: 10408, 10412, 10416 Guilford Road Sewer connections

If you are putting manholes in the right of way or pipe over 1.5" water and 4" sewer you need to do a ADO process. Do you have a plan that your thinking of doing I could look at?

From: John Heinrichs <jheinrichs@baylandinc.com>
Sent: Thursday, March 25, 2021 12:38 PM
To: Hooe, Roy <RHooe@howardcountymd.gov>
Cc: Keith Tate <ktate@baylandinc.com>
Subject: RE: 10408, 10412, 10416 Guilford Road Sewer connections

[Note: This email originated from outside of the organization. Please only click on links or attachments if you know the sender.]

Thanks Roy, the NWSS process looks a little simpler than I originally thought.
If I am reading the all the information correctly you will need,

- One scaled plan view with all three properties showing proposed location of the grinder pumps, force mains, and new manholes.
- Profiles of the force mains from the grinder pumps to the transition manhole and a profile of the gravity sewer to the doghouse manhole.

- An easement for a shared 2 ½" force main (plat & legal description) – 20' wide would accommodate future development of the 10408 property.

The submission will be submitted with the attached application.

Bureau of Utilities will review plans and easement for completeness and make comments if necessary.

Once the plans and easement documents are approved by the Bureau of Utilities the owner pays the Inspection fees and surety and receives the approved construction plans and his contractor can begin work.

Thanks again, this will help me prepare a better price for the engineering work to give the owner.

John

John Heinrichs, P.E.



From: Hooe, Roy <RHooe@howardcountymd.gov>
Sent: Thursday, March 25, 2021 6:57 AM
To: John Heinrichs <jheinrichs@baylandinc.com>
Subject: RE: 10408, 10412, 10416 Guilford Road Sewer connections

See attached

From: John Heinrichs <jheinrichs@baylandinc.com>
Sent: Wednesday, March 24, 2021 2:30 PM
To: Hooe, Roy <RHooe@howardcountymd.gov>
Subject: 10408, 10412, 10416 Guilford Road Sewer connections

[Note: This email originated from outside of the organization. Please only click on links or attachments if you know the sender.]

Thanks for talking to me earlier today.

John Heinrichs, PE
Project Manager



BayLand Consultants & Designers, Inc.
7455 New Ridge Road, Suite T • Hanover, MD 21076

☎ 410.694.9401 Main
📱 410.961.2790 Mobile
✉ jheinrichs@baylandinc.com
🌐 www.baylandinc.com

RE: 10408 and 10416 Guilford Rd - Weekly update Question

John Heinrichs <jheinrichs@baylandinc.com>

Tue 4/27/2021 10:44 AM

To: Thomas, Susan <sathomas@howardcountymd.gov>**Cc:** Keith Tate <ktate@baylandinc.com>; KENNY <kennysantos@verizon.net> 1 attachments (613 KB)

PRELIMINARY PLAN & PROFILES.pdf;

[Note: This email originated from outside of the organization. Please only click on links or attachments if you know the sender.]

Ms. Thomas,

There was some early confusion about this as the Bureau of Utilities originally indicated that Kenny would be able to connect into the sewer in Guilford Road using grinder pumps. However, when we advanced that concept design to them, they said if a gravity connection was available the grinder pumps would not be allowed. So, we are moving forward with connection to the 16" sewer in the rear of the property. See a draft of the proposed layout attached. This will mean trenching through some environmentally sensitive areas, (wetlands and stream buffer). Once we have a preliminary approval from the County DPW on the proposed alignment, we will be requesting authorizations from the County P&Z and the State to work in these sensitive areas.



Please feel free to call if you have further questions.

John

John Heinrichs, PE
Project Manager



BayLand Consultants & Designers, Inc.
7455 New Ridge Road, Suite T • Hanover, MD 21076

 410.694.9401 Main 410.961.2790 Mobile jheinrichs@baylandinc.com www.baylandinc.com

From: KENNY <kennysantos@verizon.net>
Sent: Tuesday, April 27, 2021 10:02 AM
To: John Heinrichs <jheinrichs@baylandinc.com>
Subject: Fw: 10408 and 10416 Guilford Rd - Weekly updates

Good morning John , please reply to her question

Thank you



Kenny Santos / President

Kennysantos@verizon.net

10772 Tucker St Beltsville, Md 20705

Office 301-595-3099

----- Forwarded Message -----

From: Thomas, Susan <sathomas@howardcountymd.gov>

To: KENNY <kennysantos@verizon.net>

Sent: Monday, April 26, 2021, 12:10:15 PM EDT

Subject: Re: 10408 and 10416 Guilford Rd - Weekly updates

Thank you Kenny, this looks good. Can you tell me which sewer they have decided to connect to - the one along Guilford Rd or behind the properties?

Best,

Susan

From: KENNY <kennysantos@verizon.net>

Sent: Monday, April 26, 2021 9:30 AM

To: Thomas, Susan <sathomas@howardcountymd.gov>

Subject: Re: 10408 and 10416 Guilford Rd - Weekly updates

[Note: This email originated from outside of the organization. Please only click on links or attachments if you know the sender.]

Good Morning Susan ,
this is the progress work done for 10408 and 10416 Guilford Rd for this past week .
For the Health Dept. see below:

Progress on your project this week:

- Finish processing survey and base sheet
- Prepare preliminary design plans for sewer and water connections
- Coordinate drawing requirements with Howard County
- Send Preliminary plans with Preliminary Water and Sewer Application information to Owner for review and comment.

Plans for Next Week:

- Prepare cover sheet, finalize Preliminary Plans, and complete check list items for submittal to County.
- Coordinate Erosion and Sediment Control with Ho. Co. Soil Conservation District and add to plans.
- Make on-line submittal through ProjectDox
- Coordinate payment of fees to begin the review process.

John

John Heinrichs, PE

Project Manager



The holding tanks were not full yet , I am anticipating probably Saturday , to have them pumped out .

Respectfully

Kenny



Kenny Santos / President

Kennysantos@verizon.net

10772 Tucker St Beltsville, Md 20705

Office 301-595-3099

On Wednesday, April 21, 2021, 03:41:46 PM EDT, Thomas, Susan <sathomas@howardcountymd.gov> wrote:

Dear Kenny,

Thank you for sending me the contract with BayLand Engineering and your conversations with utilities.

Can you please email me a weekly update, by 5pm every Friday, on the progress of the public connection? This includes anything that BayLand has done, any progress with utilities, and any pumping receipts for the two holding tanks. In addition, weekly inspections of the holding tanks will continue. I need to have evidence of progress before considering an extension.

Thank you. Please feel free to contact me if you have any questions.

Regards,

Susan

Susan M. Thomas

Environmental Health Specialist

Well & Septic Program

Bureau of Environmental Health

8930 Stanford Blvd.

Columbia, MD 21045

410-313-6287

sathomas@howardcountymd.gov

www.hchealth.org



twitter.com/HoCoHealth



facebook.com/HoCoHealth



instagram.com/hocohealth

CONFIDENTIALITY NOTICE

This message and the accompanying documents are intended only for the use of the individual or entity to which they are addressed and may contain information that is privileged, confidential, or exempt from disclosure under applicable law. If the reader of this email is not the intended recipient, you are hereby notified that you are strictly prohibited from reading, disseminating, distributing, or copying this communication. If you have received this email in error, please notify the sender immediately and destroy the original transmission.

Thomas, Susan

From: KENNY <kennysantos@verizon.net>
Sent: Tuesday, May 11, 2021 10:25 AM
To: Thomas, Susan
Subject: Re: No progress report on 5/7

[Note: This email originated from outside of the organization. Please only click on links or attachments if you know the sender.]

Susan , sorry i was out of town . I will request the invoice from Fogel's now and i will send it

Thanks

Kenny

Kenny,

Sorry, I am little late with my status report for this past week.

- Added non-tidal wetlands, wetland buffers, and stream buffers to the plans
- Submitted the plans, checklist, owners certification, and estimate to Howard County Planning and Zoning for acceptance.
- Received e-mail from County that the submittal was acceptable and notified Mr. Santos of the fee required to continue review. (See email chain below).

Next few things on the schedule

- Pay the review fee and submit paper plan sets; so, the County review can continue.
- Wait for comments from County review agencies.
- Review and respond to County comments, and revise and resubmit plans, as necessary for approval.
- Once alignment is approved and temporary environmental impacts can be determined
 - Request necessary disturbance waiver for impacts to wetlands & buffers from the County.
 - Submit plans to Soil Conservation District for review and approval.
 - Request letter of authorization for temporary disturbance to wetlands & buffers from State and Federal agencies. (Joint Permit Application)
- When plans and permits are approved the County will prepare a Developers Agreement for Mr. Santos to sign before Construction can begin.
- All of this will take some time and unforeseen issues may arise.

Contact me with any questions.

Thanks, John

John Heinrichs, P.E.



On Tuesday, May 11, 2021, 09:31:38 AM EDT, Thomas, Susan <sathomas@howardcountymd.gov> wrote:

Dear Kenny,

I didn't receive a progress report from you last Friday. Can you please send it to me.

Thanks,

Susan

Susan M. Thomas

Environmental Health Specialist

Well & Septic Program

Bureau of Environmental Health

8930 Stanford Blvd.

Columbia, MD 21045

410-313-6287

sathomas@howardcountymd.gov

www.hchealth.org





twitter.com/HoCoHealth



facebook.com/HoCoHealth



instagram.com/hocohealth

CONFIDENTIALITY NOTICE

This message and the accompanying documents are intended only for the use of the individual or entity to which they are addressed and may contain information that is privileged, confidential, or exempt from disclosure under applicable law. If the reader of this email is not the intended recipient, you are hereby notified that you are strictly prohibited from reading, disseminating, distributing, or copying this communication. If you have received this email in error, please notify the sender immediately and destroy the original transmission.

Thomas, Susan

From: KENNY <kennysantos@verizon.net>
Sent: Wednesday, May 19, 2021 12:34 PM
To: Thomas, Susan
Subject: FW: ProjectDox Payment Received for Guilford Road Properties W&S

[Note: This email originated from outside of the organization. Please only click on links or attachments if you know the sender.]

Susan,
The only good news we have is that the county has started the review process.
See email below

Kenny

Sent from Yahoo Mail on Android

----- Forwarded Message -----

From: "John Heinrichs" <jheinrichs@baylandinc.com>
To: "KENNY" <kennysantos@verizon.net>
Sent: Tue, May 18, 2021 at 3:39 PM
Subject: FW: ProjectDox Payment Received for Guilford Road Properties W&S

Kenny,

The review process at the County has started. See email below.

Let me know if you have any questions.

John

John Heinrichs, P.E.



From: pdoxsmtp@howardcountymd.gov <pdoxsmtp@howardcountymd.gov>
Sent: Tuesday, May 18, 2021 3:36 PM
To: John Heinrichs <jheinrichs@baylandinc.com>
Subject: ProjectDox Payment Received for Guilford Road Properties W&S



Payment Received

Attention JOHN HEINRICHS:

Payment has been received for this plan. It is now officially submitted.

Plan #	Guilford Road Properties W&S
Project Name	Guilford Road 10408, 10412, 10416
Task	Notify Applicant Payment Received
Project Access Login to ProjectDox	

Thomas, Susan

From: KENNY <kennysantos@verizon.net>
Sent: Monday, May 24, 2021 7:22 PM
To: Thomas, Susan
Subject: Fw: Guilford Rd

[Note: This email originated from outside of the organization. Please only click on links or attachments if you know the sender.]

Susan , I ask the engineer to give me an update, so please see the email forwarded.

Respectfully

Kenny

Sent from Yahoo Mail on Android

----- Forwarded Message -----

From: "John Heinrichs" <jheinrichs@baylandinc.com>
To: "KENNY" <kennysantos@verizon.net>
Sent: Mon, May 24, 2021 at 2:28 PM
Subject: RE: Guilford Rd

Kenny,

As you know, the plans and the check for the County review fee were submitted on the 18th.

This is a formal process and will take a few weeks. The plans will be distributed to several agencies within the County for review and comment. They typically have up to 45 days to respond.

I suspect we will have to address the disturbance in the environmentally sensitive areas (floodplain, wetlands, wetland buffers, & stream buffers).

We will also need an authorization from the State and Federal agencies for wetland disturbance.

I cannot calculate the impacts to those areas until I know that the proposed alignment is acceptable. If they want us to change the alignment the impacts will be different.

I did my best to avoid taking down any trees; so, most of our impacts should be temporary and I do not anticipate any difficulties; however, we will have to address any comments.

I will check on the status of their review around the June 1st. Until then there is not much we can do.

John

John Heinrichs, P.E.



From: KENNY <kennysantos@verizon.net>
Sent: Monday, May 24, 2021 12:17 PM
To: John Heinrichs <jheinrichs@baylandinc.com>
Subject: Guilford Rd

Good afternoon John , i was just checking with you for any updates since I have to report with Miss Susan

Thanks

Kenny



Kenny Santos/President

kennysantos@verizon.net

10772 Tucker St Beltsville, Md 20705

Office 301-595-3099

Thomas, Susan

From: KENNY <kennysantos@verizon.net>
Sent: Tuesday, June 1, 2021 12:07 PM
To: Thomas, Susan
Subject: NO NEWS

[Note: This email originated from outside of the organization. Please only click on links or attachments if you know the sender.]

Good morning Susan ,
just want to let you know , we don't have any updates for this week .
Respectfully

Kenny Santos

Kenny Santos/President
Kennysantos@verizon.net
10772 Tucker St Beltsville, Md 20705
Office 301-595-3099

Thomas, Susan

From: Thomas, Susan
Sent: Tuesday, June 21, 2022 9:17 AM
To: 'John Hieatzman'
Cc: Wolf, Kevin
Subject: RE: Specifications for septic system at 10408 Guilford

Yes, the specifications are a volume of 2100 gallons – so two tanks in series, however you would like to do it.

However, we're still waiting on Steve Krieg's "ok" before releasing this septic permit.

-Susan

From: John Hieatzman <john@foglesinc.com>
Sent: Tuesday, June 21, 2022 9:07 AM
To: Thomas, Susan <sathomas@howardcountymd.gov>
Cc: Wolf, Kevin <KWolf@howardcountymd.gov>
Subject: RE: Specifications for septic system at 10408 Guilford

[Note: This email originated from outside of the organization. Please only click on links or attachments if you know the sender.]

Hi Susan,

Do you have requirements for the holding tank(s) at 10416 Guilford Rd?

John Hieatzman
Fogle's Septic Clean, Inc.
580 Obrecht Rd
Sykesville, MD 21784
Phone: 410.795.5670
Email: john@foglesinc.com
Website: www.foglesseptic.com



From: Thomas, Susan [<mailto:sathomas@howardcountymd.gov>]
Sent: Wednesday, June 08, 2022 9:00 AM
To: John Hieatzman <john@foglesinc.com>; KENNY <kennysantos@verizon.net>
Cc: Wolf, Kevin <KWolf@howardcountymd.gov>
Subject: Specifications for septic system at 10408 Guilford

Dear John and Kenny,

Attached please find the specifications for the septic system repair at 10408 Guilford Rd.

Please feel free to contact me with questions.

Thanks,

Susan

Susan M. Thomas
Environmental Health Specialist
Well & Septic Program
Bureau of Environmental Health
8930 Stanford Blvd.
Columbia, MD 21045
410-313-6287
sathomas@howardcountymd.gov
www.hchealth.org



twitter.com/HoCoHealth



facebook.com/HoCoHealth



instagram.com/hocohealth

CONFIDENTIALITY NOTICE

This message and the accompanying documents are intended only for the use of the individual or entity to which they are addressed and may contain information that is privileged, confidential, or exempt from disclosure under applicable law. If the reader of this email is not the intended recipient, you are hereby notified that you are strictly prohibited from reading, disseminating, distributing, or copying this communication. If you have received this email in error, please notify the sender immediately and destroy the original transmission.

Thomas, Susan

From: KENNY <kennysantos@verizon.net>
Sent: Monday, June 21, 2021 12:07 PM
To: Thomas, Susan
Subject: Fw: Guilford Road Properties W&S

[Note: This email originated from outside of the organization. Please only click on links or attachments if you know the sender.]

fyi

Kenny Santos/President
Kennysantos@verizon.net
10772 Tucker St Beltsville, Md 20705
Office 301-595-3099

----- Forwarded Message -----

From: Gogolski, Maury <mgogolski@howardcountymd.gov>
To: John Heinrichs <jheinrichs@baylandinc.com>
Cc: KENNY <kennysantos@verizon.net>; Keith Tate <ktate@baylandinc.com>
Sent: Monday, June 21, 2021, 10:28:43 AM EDT
Subject: RE: Guilford Road Properties W&S

Hi John – Comments will be completed this week. I'll keep you posted.

Maury

From: John Heinrichs <jheinrichs@baylandinc.com>
Sent: Friday, June 18, 2021 11:29 AM
To: Gogolski, Maury <mgogolski@howardcountymd.gov>
Cc: KENNY <kennysantos@verizon.net>; Keith Tate <ktate@baylandinc.com>
Subject: RE: Guilford Road Properties W&S

[Note: This email originated from outside of the organization. Please only click on links or attachments if you know the sender.]

Maury,

Again, just checking on the status of the review of the water and sewer plans.

Don't mean to be a pest but our client needs to report regularly to the health department on progress.

Thanks again for your assistance and cooperation.

John

John Heinrichs, P.E.



From: Gogolski, Maury <mgogolski@howardcountymd.gov>
Sent: Wednesday, June 02, 2021 5:03 PM
To: John Heinrichs <jheinrichs@baylandinc.com>
Cc: KENNY <kennysantos@verizon.net>; Keith Tate <ktate@baylandinc.com>
Subject: RE: Guilford Road Properties W&S

Hi John - Comments are due 6/16, which is about 1 month from submission, and considered an expedited review. Standard Prelim review is 60 days. If I get to it sooner I will reach out with any concerns or comments.

Thanks for your patience,

Maury

Maury Gogolski

Engineering Specialist II

Department of Planning and Zoning

Development Engineering Division

410-313-2360

3430 Court House Drive

Ellicott City, Maryland 21043

From: John Heinrichs <jheinrichs@baylandinc.com>
Sent: Wednesday, June 2, 2021 4:51 PM

To: Gogolski, Maury <mgogolski@howardcountymd.gov>
Cc: KENNY <kennysantos@verizon.net>; Keith Tate <ktate@baylandinc.com>
Subject: Guilford Road Properties W&S

[Note: This email originated from outside of the organization. Please only click on links or attachments if you know the sender.]

Hi Maury,

Just checking on the status of the review of the Water and Sewer Plans for the referenced project.

Any idea when we will be receiving comments or approval?

Do you need anything else from me at this point?

Thanks, John

John Heinrichs, PE





Project Manager

BayLand Consultants & Designers, Inc.

7455 New Ridge Road, Suite T • Hanover, MD 21076

 410.694.9401 Main

 410.961.2790 Mobile
 jheinrichs@baylandinc.com

 www.baylandinc.com

Thomas, Susan

From: KENNY <kennysantos@verizon.net>
Sent: Thursday, July 1, 2021 11:15 AM
To: Thomas, Susan
Subject: Fw: Guilford Road Sewer
Attachments: 2021-6-29 24-5183-D COMMENT LETTER.pdf

[Note: This email originated from outside of the organization. Please only click on links or attachments if you know the sender.]

FYI



Kenny Santos/President
Kennysantos@verizon.net
10772 Tucker St Beltsville, Md 20705
Office 301-595-3099

----- Forwarded Message -----

From: John Heinrichs <jheinrichs@baylandinc.com>
To: KENNY <kennysantos@verizon.net>
Cc: Keith Tate <ktate@baylandinc.com>; Karen Reodique <kreodique@baylandinc.com>
Sent: Wednesday, June 30, 2021, 05:08:39 PM EDT
Subject: Guilford Road Sewer

Kenny,

Finally heard from the County today. See comments from the Developers Engineering Section attached.

Most of the comments are drafting related and will not affect the design.

We have begun making the requested changes to the drawings and I will be preparing a response to the comments.

There are still at least two agencies that will be reviewing the plans the Bureau of Utilities and Planning & Zoning Environmental folks (I copied you on our request for necessary disturbance earlier).

I would like to hear back from them before I resubmit the revised drawings.

I will keep you informed.

John

John Heinrichs, PE

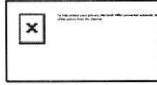

Project Manager

BayLand Consultants & Designers, Inc.

7455 New Ridge Road, Suite T • Hanover, MD 21076

 410.694.9401 Main

 410.961.2790 Mobile
 jheinrichs@baylandinc.com

 www.baylandinc.com

Thomas, Susan

From: KENNY <kennysantos@verizon.net>
Sent: Thursday, July 1, 2021 11:14 AM
To: Thomas, Susan
Subject: Fw: Guilford Road Properties W&S contract 24-5183-D
Attachments: Necessary Disturbance Request.pdf; GUILFORD ROAD PRELIMINARY DESIGN EXHIBIT.pdf

[Note: This email originated from outside of the organization. Please only click on links or attachments if you know the sender.]

Good morning Susan , see emails below to keep you in the loop

Kenny



Kenny Santos/President
Kennysantos@verizon.net
10772 Tucker St Beltsville, Md 20705
Office 301-595-3099

----- Forwarded Message -----

From: John Heinrichs <jheinrichs@baylandinc.com>
To: jschleicher@howardcountymd.gov <jschleicher@howardcountymd.gov>
Cc: KENNY <kennysantos@verizon.net>; Gogolski, Maury <mgogolski@howardcountymd.gov>
Sent: Wednesday, June 30, 2021, 04:54:12 PM EDT
Subject: Guilford Road Properties W&S contract 24-5183-D

Mr. Schleicher

Attached please find our request for a necessary disturbance of sensitive environmental areas for the referenced Public Sewer Extension project.

I have also included a copy of the preliminary plan currently under review by DPZ Development Engineering and the Bureau of Utilities for your reference.

Please let me know if you require a hard copy of the letter.

Thank you,

John Heinrichs, PE



Project Manager

BayLand Consultants & Designers, Inc.

7455 New Ridge Road, Suite T • Hanover, MD 21076

 410.694.9401 Main

 410.961.2790 Mobile

 jheinrichs@baylandinc.com

 www.baylandinc.com

Thomas, Susan

From: KENNY <kennysantos@verizon.net>
Sent: Tuesday, July 27, 2021 4:29 PM
To: Thomas, Susan
Subject: Re: Updates for week of 7/19

[Note: This email originated from outside of the organization. Please only click on links or attachments if you know the sender.]

Sorry Thursday the 5th August

Kenny Santos/President
Kennysantos@verizon.net
10772 Tucker St Beltsville, Md 20705
Office 301-595-3099

On Tuesday, July 27, 2021, 03:52:09 PM EDT, Thomas, Susan <sathomas@howardcountymd.gov> wrote:

Which Thursday are you referring to? The next Thursday coming up is 7/29.

Thanks,

Susan

From: KENNY <kennysantos@verizon.net>
Sent: Tuesday, July 27, 2021 3:42 PM
To: Thomas, Susan <sathomas@howardcountymd.gov>
Subject: Re: Updates for week of 7/19

[Note: This email originated from outside of the organization. Please only click on links or attachments if you know the sender.]

Hi Susan ,

no updates , the only thing we have is for Thursday the 23th tanks are schedule to be clean

Kenny

Kenny Santos/President

Kennysantos@verizon.net

10772 Tucker St Beltsville, Md 20705

Office 301-595-3099

On Tuesday, July 27, 2021, 03:38:30 PM EDT, Thomas, Susan <sathomas@howardcountymd.gov> wrote:

Dear Kenny,

Any updates for last week?

Thanks,

Susan

Thomas, Susan

From: KENNY <kennysantos@verizon.net>
Sent: Monday, August 9, 2021 9:20 AM
To: Thomas, Susan
Subject: Re: updates for week of 8/2

[Note: This email originated from outside of the organization. Please only click on links or attachments if you know the sender.]

Susan , good morning .

The only update i have is the cleaning of the tanks last Thursday , but they have not send me the invoice yet . as soon as i get it , will forward to you .

Kenny



Kenny Santos/President
Kennysantos@verizon.net
10772 Tucker St Beltsville, Md 20705
Office 301-595-3099

On Monday, August 9, 2021, 08:50:33 AM EDT, Thomas, Susan <sathomas@howardcountymd.gov> wrote:

Dear Kenny,

Any updates for last week?

Thanks,

Susan

Thomas, Susan

From: KENNY <kennysantos@verizon.net>
Sent: Monday, August 16, 2021 11:01 AM
To: Thomas, Susan
Subject: Fw: ProjectDox Resubmission Acceptance for 24-5183-D

[Note: This email originated from outside of the organization. Please only click on links or attachments if you know the sender.]

Good morning Susan , see email below with the latest

Kenny

Kenny Santos/President
Kennysantos@verizon.net
10772 Tucker St Beltsville, Md 20705
Office 301-595-3099

----- Forwarded Message -----

From: KENNY <kennysantos@verizon.net>
To: John Heinrichs <jheinrichs@baylandinc.com>
Sent: Monday, August 16, 2021, 10:59:07 AM EDT
Subject: Re: ProjectDox Resubmission Acceptance for 24-5183-D

Thank John for the update.

Kenny

Kenny Santos/President
Kennysantos@verizon.net
10772 Tucker St Beltsville, Md 20705
Office 301-595-3099

On Monday, August 16, 2021, 10:01:13 AM EDT, John Heinrichs <jheinrichs@baylandinc.com> wrote:

Kenny,

Not sure if you are receiving these emails (below). But wanted you to know the resubmission of the plans was accepted.

I dopped off the paper prints on Wednesday at the County office building and at the Soil Conservation District for their review.

SCD will have to sign the mylars; so, I wanted them to have a heads up.

Since it is just a trench and backfill operation they should not have much to say.

John

John Heinrichs, P.E.



From: pdoxsmtp@howardcountymd.gov <pdoxsmtp@howardcountymd.gov>

Sent: Wednesday, August 11, 2021 8:33 AM

To: John Heinrichs <jheinrichs@baylandinc.com>

Subject: ProjectDox Resubmission Acceptance for 24-5183-D

xResources and Instructions

Resubmission Acceptance

Attention JOHN HEINRICHS:

The resubmission of **24-5183-D**, is complete and has been accepted for the next review cycle. The date of the resubmission is 8/11/2021.

Please deliver three paper prints of each plan set associated with this project to Melissa Maloney within two working days if you have not already done so. Please contact the DLD project manager if you have any questions.

If applicable, please also deliver one paper print of the final water and sewer plan to the DED intake staff if you have not already done so. Please contact the DED-WS project manager if you have any questions.

Plan #	24-5183-D
Project Name	Guilford Road Properties (10408, 10412, 10416 Guilford Road)
Task	Notify Applicant Resubmit Acceptance
<u>Project Access</u> <u>Login to ProjectDox</u>	

Thomas, Susan

From: KENNY <kennysantos@verizon.net>
Sent: Tuesday, August 24, 2021 10:18 AM
To: Thomas, Susan
Subject: Guilford Rd

[Note: This email originated from outside of the organization. Please only click on links or attachments if you know the sender.]

Good morning Susan , just to let you know there was nothing new this week

Kenny



Kenny Santos/President
Kennysantos@verizon.net
10772 Tucker St Beltsville, Md 20705
Office 301-595-3099

Thomas, Susan

From: KENNY <kennysantos@verizon.net>
Sent: Wednesday, September 15, 2021 10:40 AM
To: Thomas, Susan
Subject: Re: 10408 and 10416 Guilford - updates on connecting to public sewer

[Note: This email originated from outside of the organization. Please only click on links or attachments if you know the sender.]

Susan , good morning .

We have nothing new tenants have been in vacation so probably next week we have tanks pumped out .



Kenny Santos/President
Kennysantos@verizon.net
10772 Tucker St Beltsville, Md 20705
Office 301-595-3099

On Wednesday, September 15, 2021, 09:08:00 AM EDT, Thomas, Susan <sathomas@howardcountymd.gov> wrote:

Dear Kenny,

Any updates for this week?

Thank you,

Susan

Thomas, Susan

From: KENNY <kennysantos@verizon.net>
Sent: Wednesday, September 15, 2021 10:49 AM
To: John Heinrichs
Cc: Thomas, Susan
Subject: Any update

[Note: This email originated from outside of the organization. Please only click on links or attachments if you know the sender.]

Good morning John , I have not heard anything from anybody , do you think that I should go to their offices , or that will make things worst ?

I am asking because it has been such a huge expense for me and after you complied with all their changes in the drawings , I was expecting a quicker turn around. Any suggestions?

Kenny



Kenny Santos/President
Kennysantos@verizon.net
10772 Tucker St Beltsville, Md 20705
Office 301-595-3099

Thomas, Susan

From: KENNY <kennysantos@verizon.net>
Sent: Monday, September 20, 2021 11:35 AM
To: Thomas, Susan
Subject: 10416 Guilford

[Note: This email originated from outside of the organization. Please only click on links or attachments if you know the sender.]

Good morning Susan ,
Tanks schedule to be pumped on the 23th of September



Kenny Santos/President
Kennysantos@verizon.net
10772 Tucker St Beltsville, Md 20705
Office 301-595-3099

Thomas, Susan

From: KENNY <kennysantos@verizon.net>
Sent: Thursday, September 23, 2021 7:28 AM
To: Thomas, Susan
Cc: Wolf, Kevin; Williams, Jeffrey
Subject: Re: 10416 emergency pumping inspection

[Note: This email originated from outside of the organization. Please only click on links or attachments if you know the sender.]

Will do.
Thank you Susan

Respectfully

Kenny

Sent from Yahoo Mail on Android

On Wed, Sep 22, 2021 at 3:53 PM, Thomas, Susan
<sathomas@howardcountymd.gov> wrote:

Dear Kenny,

I'm copying the below email to my supervisors to keep them in the loop.

Additionally, we may want to consider installing alarm floats in both tanks to alert you and the renters when the tanks are full before they overflow.

-Susan

From: Thomas, Susan
Sent: Wednesday, September 22, 2021 3:36 PM
To: KENNY <kennysantos@verizon.net>
Subject: 10416 emergency pumping inspection

Dear Kenny,

Thank you for your prompt response and action.

I inspected both properties today, they looked good. There was hydrated lime sprinkled over the wet areas near the second tank lid behind 10416 Guilford Rd.

Please send the invoices for the pumping as soon as you have them.

As you know, as stated in the Notice of Violation from 3/2/21, you are responsible for continuing to pump the contents of the system at a frequency that prevents sewage effluent from coming to the ground surface.

In the future, please have the tanks pumped more frequently to avoid this problem. According to my records, the tanks were last pumped on 8/4/21, which was 7 weeks ago. I would recommend pumping every 5 weeks.

If more sewage is seen at grade, this will result in a civil citation with associated fines.

Sincerely,

Susan

Susan M. Thomas

Environmental Health Specialist

Well & Septic Program

Bureau of Environmental Health

8930 Stanford Blvd.

Columbia, MD 21045

410-313-6287

sathomas@howardcountymd.gov



twitter.com/HoCoHealth



facebook.com/HoCoHealth



instagram.com/hocohealth

CONFIDENTIALITY NOTICE

This message and the accompanying documents are intended only for the use of the individual or entity to which they are addressed and may contain information that is privileged, confidential, or exempt from disclosure under applicable law. If the reader of this email is not the intended recipient, you are hereby notified that you are strictly prohibited from reading, disseminating, distributing, or copying this communication. If you have received this email in error, please notify the sender immediately and destroy the original transmission.

Thomas, Susan

From: KENNY <kennysantos@verizon.net>
Sent: Tuesday, November 30, 2021 10:14 AM
To: Thomas, Susan
Subject: Fw: Gilford Road 21-NT-3230 Santos Realty LLC/Sewer

[Note: This email originated from outside of the organization. Please only click on links or attachments if you know the sender.]

Good morning Susan,
Please read the emails below . Look like we're getting closer and closer

Sincerely

Kenny

Sent from Yahoo Mail on Android

----- Forwarded Message -----

From: "KENNY" <kennysantos@verizon.net>
To: "John Heinrichs" <jheinrichs@baylandinc.com>
Cc: "Keith Tate" <ktate@baylandinc.com>
Sent: Tue, Nov 30, 2021 at 9:10 AM
Subject: Re: Gilford Road 21-NT-3230 Santos Realty LLC/Sewer
That's great news , let's do the 10th of December at 10 AM

Thanks John

Sent from Yahoo Mail on Android

On Mon, Nov 29, 2021 at 2:30 PM, John Heinrichs
<jheinrichs@baylandinc.com> wrote:

Kenny,

MDE would like to meet at the site early next month, (see email below). They are reviewing the plan for the state and federal permits. I think they just want to confirm that the alignment makes sense and that there isn't any other current activity in the wetlands. I will be sure to let them know that you only recently purchased the property and were immediately hit with this sewer problem. You should probably plan attend the meeting as well.

Do you have any preference for the dates they mentioned below?

Call me with any questions.

John

John Heinrichs, P.E.



From: Paula Stonesifer -MDE- <paula.stonesifer@maryland.gov>
Sent: Monday, November 29, 2021 8:20 AM
To: John Heinrichs <jheinrichs@baylandinc.com>
Cc: Debra Correia -MDE- <debra.correia@maryland.gov>; Jason Traband <jtraband@baylandinc.com>
Subject: 21-NT-3230 Santos Realty LLC/Sewer

Mr. Heinrichs,

Ms. Correia and I are in receipt of your application for the project referenced in the subject line. We are available to see the site and confirm the resources on December 10th, 13th or 14th starting at 10 am. Please let us know which date works best for you as well as a good meeting location.

Thanks,

Paula



Paula Stonesifer
Natural Resources Planner
Water and Science Administration
Maryland Department of the Environment
1800 Washington Boulevard
Baltimore, Maryland 21230
paula.stonesifer@maryland.gov
410-537-3788 (O)
[Website](#) | [Facebook](#) | [Twitter](#)

[Click here to complete a three question customer experience survey.](#)

[Click here](#) to complete a three question customer experience survey.

Thomas, Susan

From: KENNY <kennysantos@verizon.net>
Sent: Sunday, December 12, 2021 8:42 PM
To: Thomas, Susan
Subject: Fw: Guilford Road Sewer MDE meeting
Attachments: MDE Encasement Detail.pdf; G2.13 Concrete Encasement.pdf

[Note: This email originated from outside of the organization. Please only click on links or attachments if you know the sender.]

Susan , meeting went very well see email with reviewed summary.

Kenny

Sent from Yahoo Mail on Android

----- Forwarded Message -----

From: "John Heinrichs" <jheinrichs@baylandinc.com>
To: "Paula Stonesifer -MDE-" <paula.stonesifer@maryland.gov>, "Debra Correia -MDE-" <debra.correia@maryland.gov>
Cc: "KENNY" <kennysantos@verizon.net>
Sent: Fri, Dec 10, 2021 at 5:33 PM
Subject: RE: Guilford Road Sewer MDE meeting

Thanks to you all for attending our site meeting this morning.

This is a brief review of the meeting.

- Met at the site 10408 Guilford Road at 10:00 am.
- Introduction were made
- Brief review of the Impacts plan
- Paula indicated that already paved surfaces could be eliminated from impact table, as those areas had already been impacted.
- Walked the alignment of the sewer in the field.
- Debra noted that the cover over the sewer where it crosses the small stream near the driveway should be 3', or sewer should be encased in concrete. Howard County standard detail for pipe encasement will be added to the construction plans.
- This stream impact also should be added to the table.
- Impacts to be revised in the table on the drawing and the concrete encasement shown.
- 11 x 17 sized digital copy of the revised drawing to be emailed to all participants within the next week.
- Should receive approval before the end of the year if we respond quickly.

These are my minutes and understanding from the meeting. Please contact me with any corrections, revisions, or additions.

Thanks again,

John

John Heinrichs, P.E.



-----Original Appointment-----

From: John Heinrichs

Sent: Wednesday, December 08, 2021 4:00 PM

To: Paula Stonesifer -MDE-; KENNY; Debra Correia -MDE-

Subject: Guilford Road Sewer MDE meeting

When: Friday, December 10, 2021 10:00 AM-11:00 AM (UTC-05:00) Eastern Time (US & Canada).

Where: 10416 Guilford Road

Just verifying meeting is still on.

Maryland's Guidelines To Waterway Construction

DETAIL 4.2(b): UTILITY CROSSING

SECTION VIEW:
ALTERNATE OPTION 1

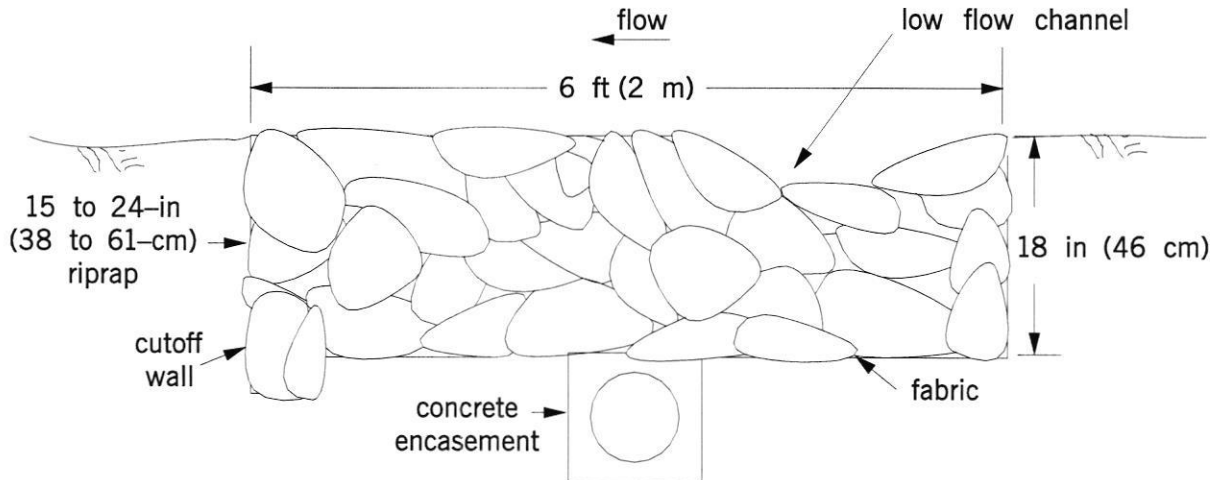

SECTION VIEW:
ALTERNATE OPTION 2

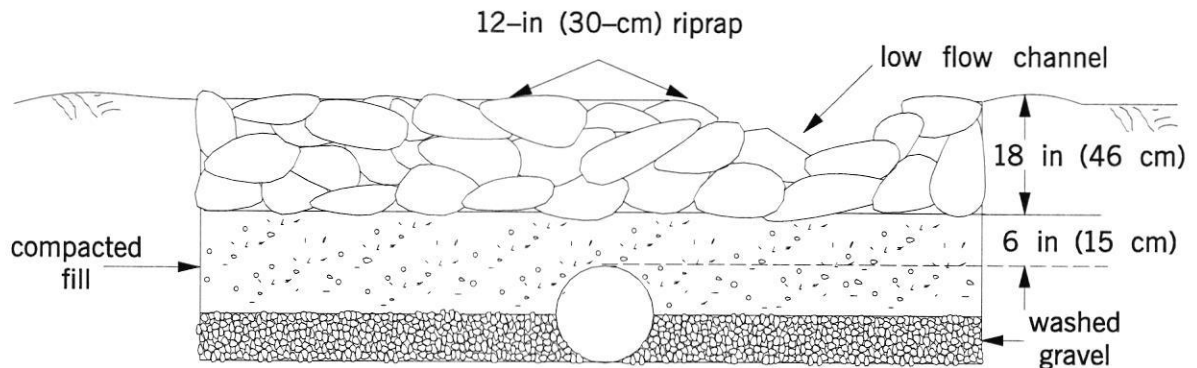

NORMAL PIPE DIAMETER	MAXIMUM PAYMENT CUBIC FT PER LINEAR FT	
	CRADLE	CONCRETE ENCASEMENT
6"	1.28	1.53
8"	1.58	2.55
10"	1.86	2.95
12"	2.33	3.63
15"	2.82	4.20
18"	4.02	5.71
21"	4.52	6.35
24"	5.95	8.22
27"	6.58	8.94
30"	7.42	9.83
33"	9.42	12.16
36"	10.53	13.09
42"	12.30	15.22
48"	16.25	19.83
54"	18.46	22.97
60"	20.80	24.95
66"	23.08	27.71

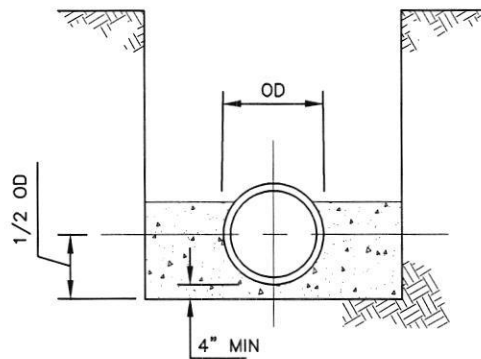
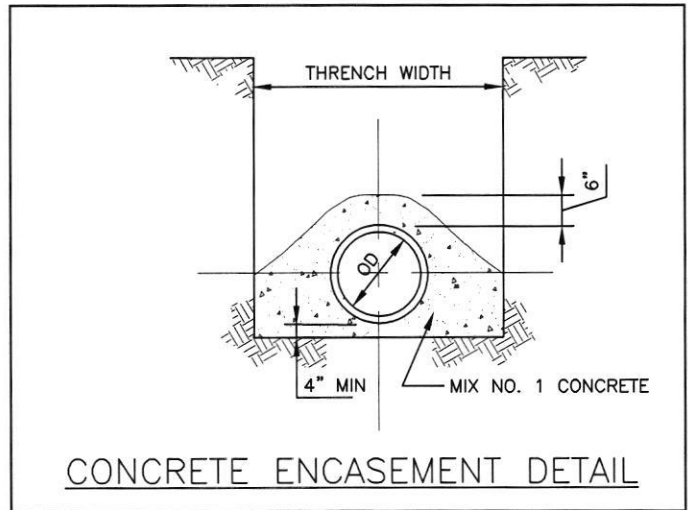

NOTES:

1. POUR CONCRETE TO UNDISTURBED EARTH.
2. CONCRETE CRADLES AND ENCASEMENT SHALL BE MIX NO. 1 CONCRETE.
3. ALL PAYMENT FOR CONCRETE ENCASEMENT OR CRADLES SHALL BE IN ACCORDANCE WITH THE TABLE ON THIS DETAIL. PAYMENT WILL NOT BE PER ACTUAL TRENCH WIDTH.
4. CONCRETE ENCASEMENTS AND CRADLES FOR WATER AND SEWER LINES ARE NOT PERMITTED WITHOUT WRITTEN AUTHORIZATION FROM THE DEPARTMENT OF PUBLIC WORKS.
5. SEE DETAIL S-3.11 AND S-3.12 FOR STREAM CROSSING DETAILS.

Revised <u>5/30/2017</u> Approved <u>5/7/2007</u> Approved	Howard County, Maryland Department of Public Works Approved: <i>Thomas E. Butler</i> Chief, Bureau of Engineering	Pipe Trench Cradle & Encasement Detail G-2.13
--	--	---

Thomas, Susan

From: KENNY <kennysantos@verizon.net>
Sent: Thursday, December 30, 2021 9:04 AM
To: Thomas, Susan
Subject: Fw: Santos Realty LLC Authorization

[Note: This email originated from outside of the organization. Please only click on links or attachments if you know the sender.]

Good morning Susan ,see the email below , that is the latest I have .
I have also checked in the tanks but they are probably another week before get pumped.

Happy holidays

Kenny

Sent from Yahoo Mail on Android

----- Forwarded Message -----

From: "KENNY" <kennysantos@verizon.net>
To: "John Heinrichs" <jheinrichs@baylandinc.com>, "Sean McKewen -MDE-" <sean.mckewen@maryland.gov>
Cc: "Paula Stonesifer -MDE-" <paula.stonesifer@maryland.gov>
Sent: Thu, Dec 30, 2021 at 8:58 AM
Subject: RE: Santos Realty LLC Authorization

Sent from Yahoo Mail on Android

On Thu, Dec 23, 2021 at 4:27 PM, John Heinrichs <jheinrichs@baylandinc.com> wrote:

Thank you and have a great holiday!

John Heinrichs, P.E.



From: Sean McKewen -MDE- <sean.mckewen@maryland.gov>
Sent: Thursday, December 23, 2021 11:55 AM
To: John Heinrichs <jheinrichs@baylandinc.com>
Cc: Paula Stonesifer -MDE- <paula.stonesifer@maryland.gov>
Subject: Santos Realty LLC Authorization

Hi John.

The Letter of Authorization for Santos Realty, LLC (21-NT-3230/202161965- work located at 10408 Guilford Road, Jessup) has been signed and a copy is attached for your information/use. A paper copy will follow in the mail.

If you have any questions, please let Paula or I know.

Sean



Sean McKewen
Western Region Chief
Nontidal Wetlands Division
Water and Science Administration
Maryland Department of the Environment
160 South Water Street
Frostburg MD 21532
sean.mckewen@maryland.gov
301-689-1493 (O)
240-362-2140 (M)
[Website](#) | [Facebook](#) | [Twitter](#)

[Click here to complete a three question customer experience survey.](#)

[Click here](#) to complete a three question customer experience survey.

Thomas, Susan

From: KENNY <kennysantos@verizon.net>
Sent: Friday, January 28, 2022 12:45 PM
To: Thomas, Susan
Subject: Fw: Guilford Road Sewer Extension - Contract 24-5183-D
Attachments: 2022-01-21 GUILFORD ROAD PROPERTIES.pdf; 2021-12-14 Guilford Road Easement Plat Rev - Santos Realty LLC.pdf; RevCostEstimate_WS.pdf

[Note: This email originated from outside of the organization. Please only click on links or attachments if you know the sender.]

FYI



Kenny Santos/President
Kennysantos@verizon.net
10772 Tucker St Beltsville, Md 20705
Office 301-595-3099

----- Forwarded Message -----

From: John Heinrichs <jheinrichs@baylandinc.com>
To: Gogolski, Maury <mgogolski@howardcountymd.gov>
Cc: KENNY <kennysantos@verizon.net>; Keith Tate <ktate@baylandinc.com>; Pickett, Jeff E <jepickett@howardcountymd.gov>
Sent: Monday, January 24, 2022, 05:32:04 PM EST
Subject: RE: Guilford Road Sewer Extension - Contract 24-5183-D

Jeff,

The requested revisions have been made to the construction plans, easement plat, and cost estimate. Digital copies are attached. See the responses below in blue.

When is the best time to come in to insert the revised documents into the original submission package for circulation? I can come in any afternoon this week except Wednesday.

Please let me know what is most convenient for you.

Thanks, John

John Heinrichs, P.E.



From: Gogolski, Maury <mgogolski@howardcountymd.gov>
Sent: Wednesday, January 19, 2022 11:35 AM
To: John Heinrichs <jheinrichs@baylandinc.com>
Cc: KENNY <kennysantos@verizon.net>; Keith Tate <ktate@baylandinc.com>; Pickett, Jeff E <jepickett@howardcountymd.gov>
Subject: RE: Guilford Road Sewer Extension - Contract 24-5183-D

John – From 'Approved Subject To' 2nd Submittal W&S Plan (see attachment) to Mylar Originals, W&S Plan was modified outside of addressing comments. For example, the easement layer was turned off, and other lines are shown along the driveway, unmarked. Also, concrete encasement was added to sewer design. Please address following comments and resubmit mylars and paper copies:

1. Show public easement line as shown on previous submissions.

Easement line is shown again.

2. Existing tree lines must be removed within public easement. Show proposed treeline 2 feet outside of public easement. Comment 17 from June 29, 2021 comment letter references this issue, was not addressed.

Limits of clearing are shown and labeled.

3. Remove newly added dashed lines along driveway, or justify their purpose and label. They should not obstruct public sewer easement.

Dashed lines have been removed. They were existing access easement to 10416 and have no bearing on this project. They are still shown and labeled on the easement plat.

4. Remove concrete encasement from sewer design, shown and labeled between manholes 3 and 4 on plan view and profile. Per Design Manual Volume II, Section 5.10.A – "*The concrete encasement of sewer or water mains will not be considered as an option for any installations.*" Concrete encasement was not proposed on previously approved plan set.

During the field walk with MDE they requested concrete encasement below the stream. Since it is in conflict with the design manual, we have removed it.

5. Existing easement label on profile, relocate to top of profile and dimension above the profile, not within. Typical profiles show location dimensions at top or above (manhole circles) profiles instead of within. As previously commented by George Gibson, remove "For Domestic & Industrial Waste Sewer" from existing 30' easement label.

The label was relocated and revised as requested. The adjacent existing Industrial Waste line was also added to the profile for clarity.

6. As previously commented by George Gibson, only three SHCs are shown on plan, not 4 as stated in proposed chart below Location Map. Proposed SHC for 10408 vacant property must be shown up to edge of easement with cleanout placed at edge of easement, not a 5' stub.

A cleanout with a plug has been shown and labeled at the edge of the easement for a future connection.

7. 10416 SHC at MH-3 – Crown of SHC at manhole must match sewer main crown into manhole, or placed above sewer main crown and meet standard manhole or drop manhole requirements.

The inverts of the SHC have been raised in MH-3 and MH-4 to match the crown of the 8" sewer main.

8. Sheet 2 label – Remove "Site" and label as "Plan View" to avoid confusion with actual site plan/site development plan (SDP).

The label has been changed as requested.

9. Update Quantities Table and Cost Estimate for additional SHC pipe for 10408 property.

Quantities table and Cost Estimate have been updated as requested.

10. Grant of Easement Exhibit Signature Block – Replace "Bureau of Engineering" with "Development Engineering".

The signature line label has been changed as requested.

Please coordinate with Jeff Pickett to pick up Approval Package to address comments. Package will be on my desk. Feel free to call to discuss.

Sincerely,

Maury

Maury Gogolski

Engineering Specialist II

Department of Planning and Zoning

Development Engineering Division

410-313-2360

3430 Court House Drive

Ellicott City, Maryland 21043

From: John Heinrichs <jheinrichs@baylandinc.com>

Sent: Wednesday, December 15, 2021 3:22 PM

To: Gogolski, Maury <mgogolski@howardcountymd.gov>

Cc: KENNY <kennysantos@verizon.net>; Keith Tate <ktate@baylandinc.com>
Subject: Guilford Road Sewer Extension - Contract 24-5183-D

[Note: This email originated from outside of the organization. Please only click on links or attachments if you know the sender.]

Maury,

Attached is a digital copy of the final submittal I dropped off downstairs at the County earlier this afternoon.

Just a single copy of everything.

Please call me if you have any concerns or questions.

Thanks, John

John Heinrichs, PE



Project Manager

BayLand Consultants & Designers, Inc.

7455 New Ridge Road, Suite T • Hanover, MD 21076

☎ 410.694.9401 Main

📱 410.961.2790 Mobile

✉ jheinrichs@baylandinc.com

🌐 www.baylandinc.com

Thomas, Susan

From: KENNY <kennysantos@verizon.net>
Sent: Thursday, February 10, 2022 10:19 AM
To: Thomas, Susan
Subject: Re: updates for 2/7/22

[Note: This email originated from outside of the organization. Please only click on links or attachments if you know the sender.]

Good morning Susan , unfortunately we don't have anything new . I am still waiting on the county responses from last email i forwarded you

Have a nice day

Kenny



Kenny Santos/President
Kennysantos@verizon.net
10772 Tucker St Beltsville, Md 20705
Office 301-595-3099

On Thursday, February 10, 2022, 09:33:36 AM EST, Thomas, Susan <sathomas@howardcountymd.gov> wrote:

Hi Kenny,

Any updates?

Thanks,

Susan

Thomas, Susan

From: KENNY <kennysantos@verizon.net>
Sent: Thursday, February 17, 2022 11:01 AM
To: Thomas, Susan
Subject: Re: updates for 2/14/22

[Note: This email originated from outside of the organization. Please only click on links or attachments if you know the sender.]

Nothing new this week , waiting on the county to send me developer's application so we can start the work.
Thank you Susan

Sent from Yahoo Mail on Android

On Thu, Feb 17, 2022 at 9:17 AM, Thomas, Susan
<sathomas@howardcountymd.gov> wrote:

Dear Kenny,

Any updates for this week?

Thanks,

Susan

Susan M. Thomas

Environmental Health Specialist

Well & Septic Program

Bureau of Environmental Health

8930 Stanford Blvd.

Columbia, MD 21045

410-313-6287

sathomas@howardcountymd.gov

Thomas, Susan

From: KENNY <kennysantos@verizon.net>
Sent: Thursday, February 24, 2022 4:01 PM
To: Thomas, Susan
Subject: Re: updates for 2/21/22

[Note: This email originated from outside of the organization. Please only click on links or attachments if you know the sender.]

Hello Susan , nothing new , i am scheduling clean up for Monday . Will send the invoice as soon is done

Thank you



Kenny Santos/President
Kennysantos@verizon.net
10772 Tucker St Beltsville, Md 20705
Office 301-595-3099

On Thursday, February 24, 2022, 03:02:52 PM EST, Thomas, Susan <sathomas@howardcountymd.gov> wrote:

Dear Kenny,

Any updates this week?

Thanks,

Susan

Thomas, Susan

From: KENNY <kennysantos@verizon.net>
Sent: Tuesday, March 1, 2022 9:51 AM
To: Thomas, Susan
Subject: Fw: Message from KM_C224e
Attachments: SKM_C224e22030109510.pdf

[Note: This email originated from outside of the organization. Please only click on links or attachments if you know the sender.]

Good morning Susan , please see attachment with DPZ letter , I am very happy about this .
Will keep you informed as we progress

Thank you for your patience

Kenny



Kenny Santos/President
Kennysantos@verizon.net
10772 Tucker St Beltsville, Md 20705
Office 301-595-3099

----- Forwarded Message -----

From: scans@gnicontracting.net <scans@gnicontracting.net>
To: "kennysantos@verizon.net" <kennysantos@verizon.net>
Sent: Tuesday, March 1, 2022, 09:43:54 AM EST
Subject: Message from KM_C224e

Thomas, Susan

From: KENNY <kennysantos@verizon.net>
Sent: Tuesday, March 15, 2022 5:26 PM
To: Thomas, Susan
Subject: Re: updates for 3/15

[Note: This email originated from outside of the organization. Please only click on links or attachments if you know the sender.]

Good afternoon Susan, we have nothing new for this week

Thanks
Sent from Yahoo Mail on Android

On Tue, Mar 15, 2022 at 3:59 PM, Thomas, Susan
<sathomas@howardcountymd.gov> wrote:

Dear Kenny,

Any updates?

Thank you,

Susan

Susan M. Thomas

Environmental Health Specialist

Well & Septic Program

Bureau of Environmental Health

8930 Stanford Blvd.

Columbia, MD 21045

410-313-6287

Thomas, Susan

From: Wolf, Kevin
Sent: Monday, April 11, 2022 1:27 PM
To: Thomas, Susan
Subject: RE: Letter of Estimated time to start and finish water and sewer city hook up .

Susan,

We need to have Mike look over this to see what his thoughts are. I think we need to force the permitted "temp" holding tanks but this will be Mike's call. Let's go over this with him tomorrow.

Kevin

From: KENNY <kennysantos@verizon.net>
Sent: Monday, April 11, 2022 1:15 PM
To: Wolf, Kevin <KWolf@howardcountymd.gov>
Cc: Thomas, Susan <sathomas@howardcountymd.gov>
Subject: Letter of Estimated time to start and finish water and sewer city hook up .

[Note: This email originated from outside of the organization. Please only click on links or attachments if you know the sender.]

April 11 2022

Mr. Kevin Wolf / Mis.Susan Thomas ,

This email/letter is in regard to my interest in informing you about the situation for connecting the public water and sewer to the properties located at 10408, 10416 and 10412 Guilford Rd Jessup MD 20794. About a year ago I decided to change failing sewer tanks after I have bought the property without going to the proper way of pulling permits to install new holding tanks . The Health Dept that you represent , has been very fear and letting me continue using this tanks as long as I could keep the cleaning of the tanks as needed . Even though its been very high cost effect for me , we have kept our word with the cleaning process . I started working in the process of the public works previous to the installation of the tanks , all this process is new to me , even though I own a drywall and painting company , this is far for my knowledge , so I hired an Engineer company to help me out and I thank God we are at the final stage with HC Public Works filling the application, providing Bond and check for all the work also new title report for all the properties currently working on it by Attorney William Callahan (301-474-7777) As soon as the title work is done the application will be submitted. I also emailed Nicholo Steward with public works and real estate service division this morning and He answered the follows:

Kenny,

Once we receive everything we've asked for, it will take us about 3 week to draft the agreements.

The agreements will need to be signed/notarized on your end and returned to us. Then, the agreements will be sent around for County signatures. Once the agreements are signed by the county, they will have to be recorded at Land Records. Unfortunately, it's difficult to estimate how long this process will take.

Nic Stewart

Thomas, Susan

From: KENNY <kennysantos@verizon.net>
Sent: Thursday, January 20, 2022 12:30 PM
To: Thomas, Susan
Subject: Fw: Guilford Road Sewer Extension - Contract 24-5183-D
Attachments: GUILFORD ROAD 2nd Submittal.pdf

[Note: This email originated from outside of the organization. Please only click on links or attachments if you know the sender.]

Good afternoon Susan , see forwarded email from yesterday
Getting closer and closer

Kenny



Kenny Santos/President
Kennysantos@verizon.net
10772 Tucker St Beltsville, Md 20705
Office 301-595-3099

----- Forwarded Message -----

From: Gogolski, Maury <mgogolski@howardcountymd.gov>
To: John Heinrichs <jheinrichs@baylandinc.com>
Cc: KENNY <kennysantos@verizon.net>; Keith Tate <ktate@baylandinc.com>; Pickett, Jeff E <jepickett@howardcountymd.gov>
Sent: Wednesday, January 19, 2022, 11:34:47 AM EST
Subject: RE: Guilford Road Sewer Extension - Contract 24-5183-D

John – From 'Approved Subject To' 2nd Submittal W&S Plan (see attachment) to Mylar Originals, W&S Plan was modified outside of addressing comments. For example, the easement layer was turned off, and other lines are shown along the driveway, unmarked. Also, concrete encasement was added to sewer design. Please address following comments and resubmit mylars and paper copies:

1. Show public easement line as shown on previous submissions.
2. Existing tree lines must be removed within public easement. Show proposed treeline 2 feet outside of public easement. Comment 17 from June 29, 2021 comment letter references this issue, was not addressed.
3. Remove newly added dashed lines along driveway, or justify their purpose and label. They should not obstruct public sewer easement.

4. Remove concrete encasement from sewer design, shown and labeled between manholes 3 and 4 on plan view and profile. Per Design Manual Volume II, Section 5.10.A – “*The concrete encasement of sewer or water mains will not be considered as an option for any installations.*” Concrete encasement was not proposed on previously approved plan set.
5. Existing easement label on profile, relocate to top of profile and dimension above the profile, not within. Typical profiles show location dimensions at top or above (manhole circles) profiles instead of within. As previously commented by George Gibson, remove “For Domestic & Industrial Waste Sewer” from existing 30’ easement label.
6. As previously commented by George Gibson, only three SHCs are shown on plan, not 4 as stated in proposed chart below Location Map. Proposed SHC for 10408 vacant property must be shown up to edge of easement with cleanout placed at edge of easement, not a 5’ stub.
7. 10416 SHC at MH-3 – Crown of SHC at manhole must match sewer main crown into manhole, or placed above sewer main crown and meet standard manhole or drop manhole requirements.
8. Sheet 2 label – Remove “Site” and label as “Plan View” to avoid confusion with actual site plan/site development plan (SDP).
9. Update Quantities Table and Cost Estimate for additional SHC pipe for 10408 property.
10. Grant of Easement Exhibit Signature Block – Replace “Bureau of Engineering” with “Development Engineering”.

Please coordinate with Jeff Pickett to pick up Approval Package to address comments. Package will be on my desk. Feel free to call to discuss.

Sincerely,

Maury

Maury Gogolski

Engineering Specialist II

Department of Planning and Zoning

Development Engineering Division

410-313-2360

3430 Court House Drive

Ellicott City, Maryland 21043

From: John Heinrichs <jheinrichs@baylandinc.com>
Sent: Wednesday, December 15, 2021 3:22 PM
To: Gogolski, Maury <mgogolski@howardcountymd.gov>
Cc: KENNY <kennysantos@verizon.net>; Keith Tate <ktate@baylandinc.com>
Subject: Guilford Road Sewer Extension - Contract 24-5183-D

[Note: This email originated from outside of the organization. Please only click on links or attachments if you know the sender.]

Maury,

Attached is a digital copy of the final submittal I dropped off downstairs at the County earlier this afternoon.

Just a single copy of everything.

Please call me if you have any concerns or questions.

Thanks, John

John Heinrichs, PE



Project Manager

BayLand Consultants & Designers, Inc.

7455 New Ridge Road, Suite T • Hanover, MD 21076

☎ 410.694.9401 Main

📱 410.961.2790 Mobile

✉ jheinrichs@baylandinc.com

🌐 www.baylandinc.com