

Approved 4/19/23

-H.O.

Record Detail * (This section is required.)

Permit Type	Permit Number	Opened Date
Building/Residential/Misc/Deck	B23001302	04/18/2023

Description of Work
SFD/construct 22x18 PAVILLION

[check spelling](#)

Address * (This section is required.)

Search Reset Clear Get Parcel & Owner

Street #	Street Name	Street Type	
6818	OWINGS OVERLOOK	--Select--	
Unit Type	Unit #	X Coordinate	Y Coordinate
--Select--		-76.96278	39.18179
City	State	Zip Code	Primary
HIGHLAND	MD	20777	Yes

Parcel * (This section is required.)

Search Reset Clear Get Address & Owner

GIS ID *	Parcel	Parcel Area	Land Value	Improved Value	Exemption Value	Plan Area
1102699	44	0.85	248000	1214200	966200	RURAL

Legal Description
IMPSLOT 24, .853 A.[]6818 OWINGS OVERLOOK WAY[]OWINGS PROP

[check spelling](#)

Block	Lot	Census Tract	Council Dist	Inspection Dist	Supervisor Dist	Map #	DAP Zone
	24	605101	5				
Plan Area	State Tax Id	Subdivision Name					
	1405595243	Owings Property					
Section	Area	Tax Map					
		40					
Grid	Zoning District	ADC Map					
40-4	RR-DEO	5051-F1					
SDP No.	Final Plan No.	WP File No.					
	F-06-112						
Record Plat No.	WS Contract No.	FDP No.	Primary				
22325			Yes				
Owner Occupied	Year Built	Historic District					
<input type="radio"/> Yes <input type="radio"/> No	2014	<input type="radio"/> Yes <input checked="" type="radio"/> No					
Historic District Registry No.	Stat Area	Flood Plain					
	5-04A	<input type="radio"/> Yes <input checked="" type="radio"/> No					
Building No							

Owner * (This section is required.)

Search Reset Clear

Name *
BAWA AMANDEEP S

Address Line 1
6818 OWINGS OVERLOOK

Address Line 2

Address Line 3

Mail City HIGHLAND	Mail State MD	Mail Zip Code 20777
Phone 240-393-8039	Primary Yes	
E-mail mexicanadeck@gmail.com		
Cell Number 2403938039	Fax Number	

Professionals (This section is not required.)

License # * 08010112470	Business Name MDP DECK AND PATIOS LLC		
License Type * MHIC Ind	First Name IVAN	Middle Name	Last Name REYES
Primary Yes	Address Line 1 3400 RITCHIE MARLBORO RD		
	Address Line 2 3400 RITCHIE MARLBORO RD		
	City UPPER MARLBORO	State MD	ZIP Code 20772-0000
	Phone 1 2403938039	Phone 2	Fax
	E-mail MARYLANDDECK@YAHOO.COM		

Applicant (This section is not required.)

Search As Owner As Lic. Prof As Contact

Type * Applicant	First Name IVAN	MI	Last Name REYES
Relationship -Select-	Full Name		
Primary Yes	Organization Name MDP DECK AND PATIOS LLC		
	Street Address 3400 RITCHIE MARLBORO RD		
	Address Line 2 3400 RITCHIE MARLBORO RD		
	City UPPER MARLBORO	State MD	Zip Code 20772-0000
	Phone 2403938039	Cell	Fax
	E-mail * MARYLANDDECK@YAHOO.COM		

Addl Info

Est Construction Cost * 9000	Housing Units * 0	Number of Buildings * 0	Public Owned No
Construction Type -Select-			

MISC PERMIT INFO

MISCELLANEOUS PERMIT INFORMATION

Capital Project-No Fee * <input type="radio"/> Yes <input checked="" type="radio"/> No	Capital Project Number <input type="text"/>	Fee Exempt * <input type="radio"/> Yes <input checked="" type="radio"/> No	Roadside Tree Project Permit * <input type="radio"/> Yes <input checked="" type="radio"/> No	Roadside Tree Project Permit # <input type="text"/>
Existing Use * Multi Family	Water Private	Sewage Private	Expiration Date 10/16/2023	

Submit Cancel

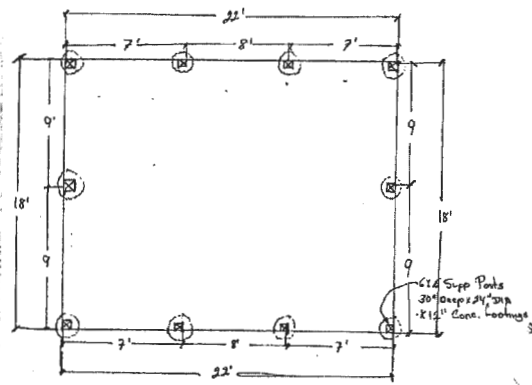

01 FOUNDATION PLAN
A-2 SCALE: 1/4" = 1'-0"

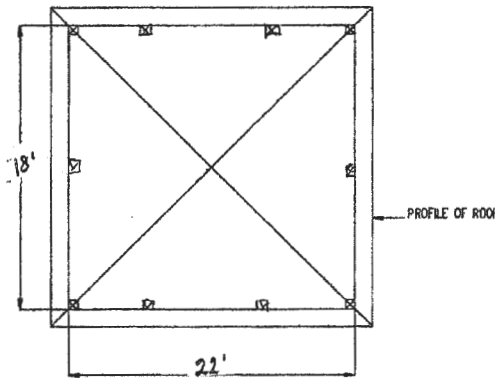

02 PROPOSED PAVILLION
A-2 SCALE: 1/4" = 1'-0"

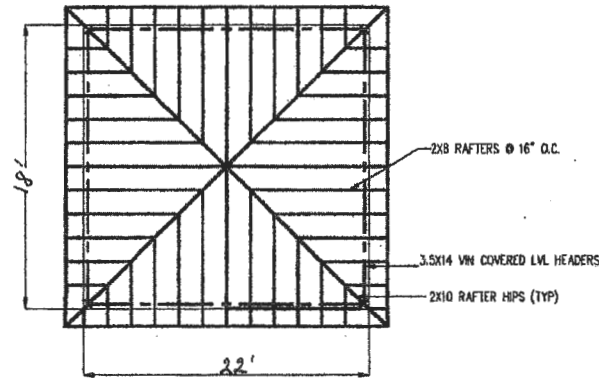

03 ROOF FRAMING
A-2 SCALE: 1/4" = 1'-0"

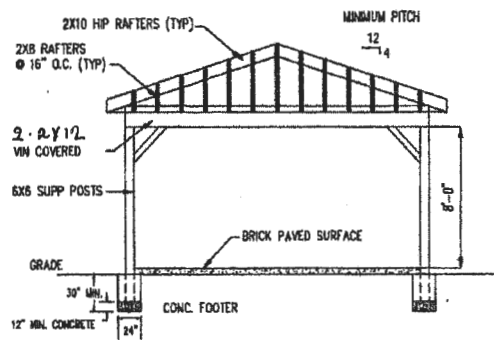

04 FRONT ELEVATION
A-2 SCALE: 1/4" = 1'-0"

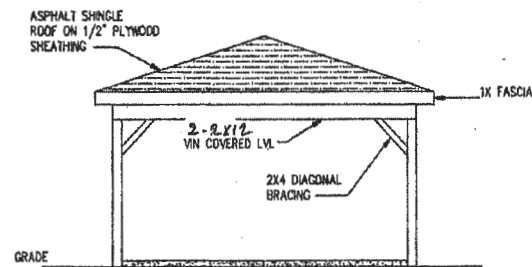

05 SIDE ELEVATION
A-2 SCALE: 1/4" = 1'-0"

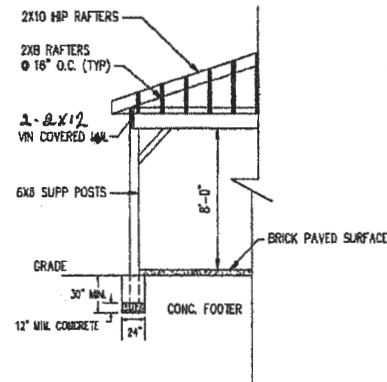

NOTE: SIMON L SHIP CONNECTIONS USED AT ROOF LEVEL FOR BRACING (TYP)

HAIRLINE NTS USED AT RAFTERS AND HEADER BEAM CONNECTION (TYP)

06 SECTION