

Oswald, Hank

From: Allen, Nancy
Sent: Monday, September 09, 2019 1:13 PM
To: Oswald, Hank
Subject: RE: Public Water and Sewer Connection Inquiry

Hello,
2605 North Rogers Ave, was connected to public water, 12/02/1980.
Not connected to public sewer.

Please let me know if you have further questions.
Thank You,
Nancy Allen
nallen@howardcountymd.gov

From: Oswald, Hank
Sent: Monday, September 9, 2019 12:53 PM
To: Allen, Nancy <nallen@howardcountymd.gov>
Subject: Public Water and Sewer Connection Inquiry

Hi Nancy:

Good afternoon. Can you tell me if 2605 North Rodgers Ave in Ellicott City is connected to public water and sewer?

Thanks,

Hank

Hank Oswald
Licensed Environmental Health Specialist
Howard County Health Department
Bureau of Environmental Health
Well & Septic Program
8930 Stanford Boulevard
Columbia, MD 21045
410.313.1786 (Office)
hoswald@howardcountymd.gov

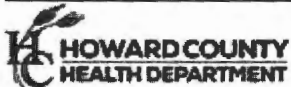

CONFIDENTIALITY NOTICE

This message and the accompanying documents are intended only for the use of the individual or entity to which they are addressed and may contain information that is privileged, confidential, or exempt from disclosure under applicable law. If the reader of this email is not the intended recipient, you are hereby notified that you are strictly prohibited from reading, disseminating, distributing, or copying this communication. If you have received this email in error, please notify the sender immediately and destroy the original transmission.

DRIP DISPOSAL SYSTEM

JOB NAME

TOM GLORIOSO
~~Huetell~~
OWNERS NAME

LOCATION

NAME TOM GLORIOSO
STREET NAME 2605 North Rodgers
CITY, STATE ZIP ELICOTT CITY, MD.

MANUFACTURED BY

AMERICAN MANUFACTURING COMPANY INC.
5517 WELLINGTON ROAD
GAINESVILLE, VA. 22065

TABLE OF CONTENTS

1. OWNERS RESPONSIBILITY
2. PROCESS DESCRIPTION
3. DATA REGISTERS
4. CONTROL WIRING
5. CENTRAL UNIT INSTALLATION
6. STARTUP SHEET
7. MONITORING AGREEMENT

OPERATION & MAINTENANCE MANUAL

OWNERS RESPONSIBILITY

The system is described in the PROCESS DESCRIPTION section of the manual. Some maintenance and troubleshooting may require specialized procedures by trained personnel. A maintenance contract providing for periodic inspection and evaluation is highly recommended. Contact American Manufacturing (1-800-345-3132) for information.

Remember that sewage and electricity can be fatally hazardous and must be handled with extreme care.

PREVENTATIVE MAINTENANCE:

1. A timer control panel controls the discharge of effluent from the septic tank effluent pump station in to the drip disposal system pump tank. The drip disposal system pump tank is a equalization pump tank which periodically doses the drip field on a timed basis. Since the pump tank provide flow equalization, excess water use may result in a high level alarm. In the event of a high level alarm press the silence button on the side of the control panel and call American or qualified contractor.
2. The entire sewage disposal system must be protected from any possible damage. The drainfield area should receive only the most passive yard type use. No use is recommended when conditions are wet. Under no conditions are any autos or large machinery to be allowed on the site. The site should be established as a healthy lawn. Wooded areas should be mulched to stabilize the site. Erosion of the site and the adjacent areas should be controlled and eliminated. Divert all surface water flows away from all portions of the system.
3. All processes in this sewage disposal system use biological treatment to renovate the wastewater. Only biodegradable typical household wastes are to be placed in the system. Never dispose of pesticides, oil based products, or solids (especially feminine hygiene products) into the system. Minimize disposal of over the counter type household products such as bleach and don't use colored toilet tissues.
4. The septic tank and pump chambers should be inspected at least once a year. Pump the septic tank when the sludge level is at 25% or approximately 12" and/or when the scum layer is on top is excessive.
5. The drip field should be inspected at least monthly in the beginning of the operation and then as necessary. After six months of good operation the system should be inspected annually.
6. **CONTROL PANEL:** The control panel comes with a wiring schematic and a description of operation. Any troubleshooting or repairs are to be performed by a factory trained electrician or representative. The switches and indicator lights are clearly marked in the control panel which controls the recirculation chamber pump / dosing chamber pump. These pumps are activated by a timer and float switches respectively. High water alarm conditions will be signaled by audio/visual methods when there is a high level condition in the pump chamber. Alarms are automatically dialed to a receiver at American but the owner should call if no response is received within 24 hours due to phone company problems.
7. A high water alarm condition in the pump chamber could be due to pump failure, excessive infiltration, or an unusually large peak flow. Prior to requesting service the owner should call the service agent to determine cause of problem.

***IF YOU HAVE ANY QUESTIONS, FEEL FREE TO CALL
AMERICAN MANUFACTURING AT 1-800-345-3132 FOR ASSISTANCE***

W-25 SYSTEM OPERATIONAL CHECK LIST

I. CONTROL LIGHTS AND MANUAL SWITCH POSITIONS

1. Circuit card LED's; green light and red light on
2. Microprocessor input; floats
3. Microprocessor output; auto run mode
4. Make sure all manual override switches are in the automatic position.
5. On the circuit card the dip switches should be on "run" and error test "off".

II. PUMP TANK LIQUID LEVEL

1. Check liquid level in pump tank to confirm switch operation.

III. PUMP AND VALVE OPERATION

1. Place pump "H-O-A" switch in the "H" position to dead head pump against valves. The flow meter should show no flow, and there should be no leaks.
2. With the pump running, place each zone valve in the hand position one at a time to check operation. With the valve open, flow should register on the flow meter. When the valve closes, the flow should stop.
3. With the pump in the manual position place the filter backwash switch in the filter one position for 10 seconds the in filter two position for 10 seconds. There should be no flow registering in the flow meter and you should hear the valves open and close.

IV. FIELD CONDITIONS

1. Walk the field to determine if wet spots are visible.

V. ZONE DOSE RATES

1. Determine how many zones are in operation and the installed flow rates from the installation records.
2. With the pump in the on position, select the first zone by placing the zone valve switch in the on position. After a 3 minute pressurization time check the flow rate by reading the flow meter for a timed minute.
3. Repeat this sequence for each zone.
4. Return all switches to the automatic position.
5. After the final zone is checked, open the field flush valve and determine that the flow rate increased to provide field flushing.

AMERICAN MANUFACTURING COMPANY, INC.

DRIP DISPOSAL SYSTEM

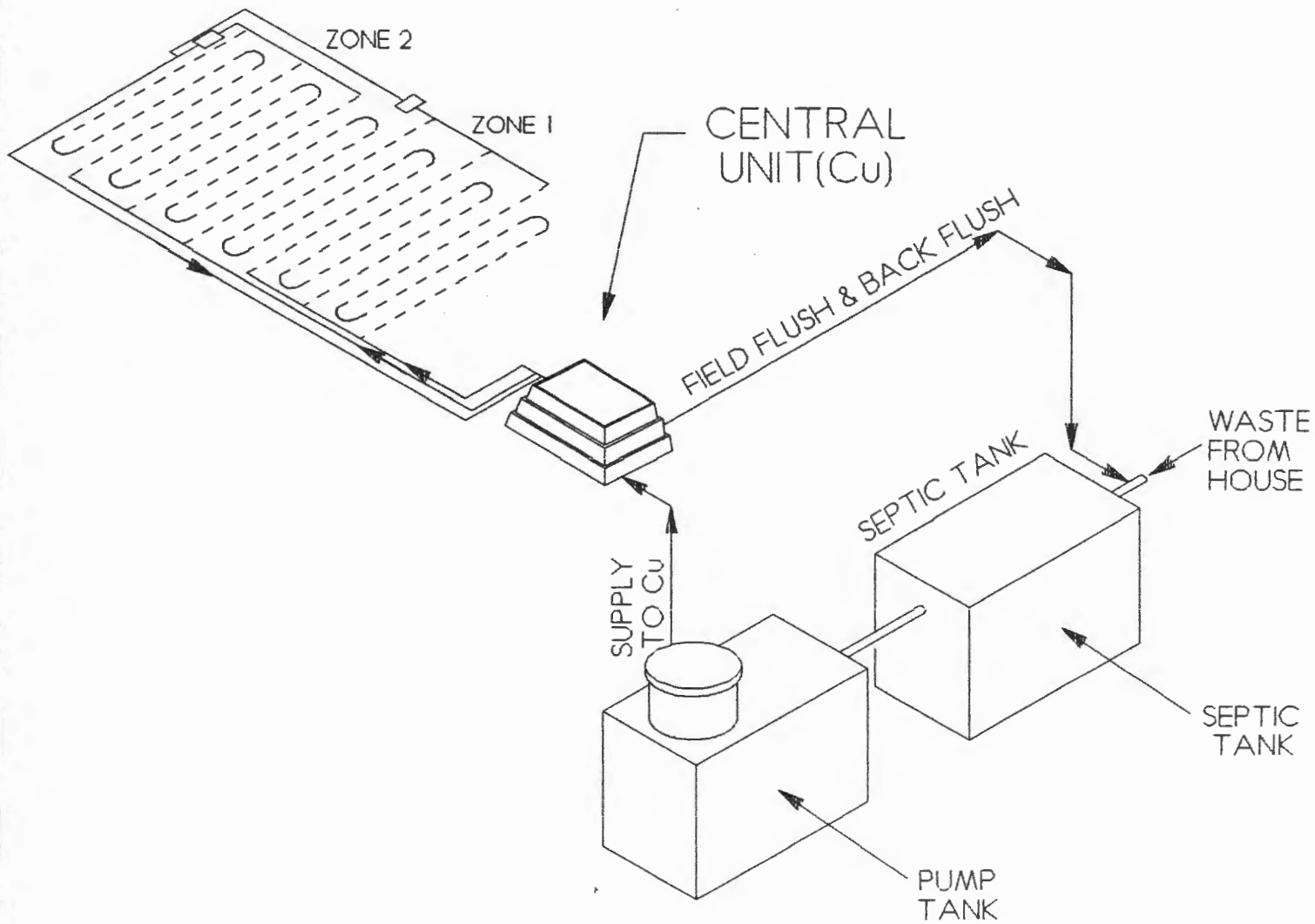

SCHEMATIC

DRIP DISPOSAL SYSTEM

PROCESS DESCRIPTION

BACKGROUND

The DRIP DISPOSAL SYSTEM waste water disposal system is a unique ALTERNATIVE fluid handling system for distributing effluent in subsurface. The system incorporates filtration, time and level controlled application, and ultra low rate distribution and drip disposal in a soil based system.

In conditions where "Low Pressure Distribution" septic effluent is required or where land application with the use of conventional soil absorption fields are not acceptable, we offer a unique system followed by subsurface distribution of the waste water effluent. The DRIP DISPOSAL SYSTEM system will accommodate virtually any type of pretreatment process, whether septic tank (anaerobic) or aerobic, from a tank or lagoon, or any type of treatment facility.

OPERATION

The DRIP DISPOSAL SYSTEM is operated via a "state of the art" controller which is activated by a sensing device (standard float switch) located in a dosing tank downstream from pretreatment (typically a septic tank). When activated by the rising level of effluent in the dosing tank, the controller will enable the disposal cycle and pump the effluent through a 115 micron disc filter.

The pump delivers unfiltered effluent to each filter. The back flushing schedule is triggered at the beginning of each dose cycle and, one filter valve closes, thus blocking the flow of unfiltered effluent to that filter. After a short delay, the flushing valve opens, thereby backflushing the filter and discharging the accumulated impurities into the pretreatment device. The closing and opening procedure of the filter and back flush valves causes a change of flow within the unit to provide filtered water from one filter to backflush the other filter. The backflush procedure lasts approximately fifteen seconds, upon where the back flushing valve closes, then the filter valve opens and the inverted flow is cut off. Only after the first filter has completed its flushing cycle, will the second filter begin its cycle of back flushing in the same manner as the first.

After the backflushing cycle the effluent passes through each filter main valve, then through the filter itself, while the filter back flushing valve remains closed. The filtered effluent flows through the outlet manifold and is discharged below the soil surface through a patented chemical-resisting pressure compensating "drip" poly-tubing.

DRIP DISPOSAL SYSTEM

The dripper lines are automatically flushed every 200 dosing cycles. This function is activated by the controller which opens the field flush valve, thus allowing the flushed effluent to be returned to the pretreatment tank. The duration of this cycle is approximately three minutes. The flushing action creates a high velocity of the effluent which produces a cleaning action over the inside walls of the dripper tubing, P.V.C. manifolds and emitters.

The construction of the RAM drip tubing is unique in that the internal diaphragm and labyrinth provided for an exact amount of effluent to be discharged from each of its emitters which are normally spaced at two foot intervals along the entire length of the RAM drip tubing. Each emitter maintains a constant flow over pressure ranges of 5 up to 60 psi. Because the effluent is distributed at an ultra low rate, large quantities of effluent may be economically distributed over large areas over controlled periods of time without saturating the surrounding soil.

If any of the below conditions occur, the controller will automatically telephone the manufacturers central service computer on any of the following conditions:

High Water
20 % Flow Variance
50 % Flow Variance

Power Out
Restoration of all Conditions

In the event of a power outage or a high water condition, an audio alarm will sound. Simultaneously, the service center can be notified via telephone link up through a digital communications receiver. Should a flow variance (plus or minus 20%) occur, a signal will be transmitted to the service center indicating this trouble. A minimum of 24 hours storage capacity is designed into the system should a power failure occur.

Since the field distribution lines require very little soil disturbance, and effluent discharge volume from each emitter hole is insignificant, installation of the system has very little site impact even in established lawns or park areas. There are no visible indications that the installation site is being used for disposal purposes. This distribution system will permit waste water disposal in land areas that are used for such purposes as parks, athletic fields, groves and highway rights of way. This system is especially suited for landscaped or wooded areas near buildings, trailer parks, apartment complexes or residential subdivisions.

r\amipro\drip\aprocesa

DRIP DISPOSAL SYSTEM MODEL DP24 - 4 ZONES

JOB NAME: _____

ZONE 1: ✓

FILE NAME: _____

ZONE 2: ✓

MODEL NUMBER: _____

ZONE 3: Future

STARTUP DATE: _____

ZONE 4: Future

LOCATION DESCRIPTION: _____

SITE SPECIFIC INPUT REGISTERS

- ◆ D500 NUMBER OF ZONES IN USE 2
- ◆ D501 ZONE DOSE TECHNIQUE (1=ALTERNATING) 1
- ◆ D503 NUMBER OF DISC FILTERS IN USE(2 OR 3) 2
- ◆ D504 SAND FILTER RETURN (0=NO/1=YES) 0
- ◆
- ◆ D200 ZONE DOSE INTERVAL
- ◆ C100 COUNTER FOR ZONE DOSE INTERVAL
- ◆ D203 SAND FILTER ZONE DOSE INTERVAL
- ◆ C103 COUNTER FOR SF DOSE INTERVAL
- ◆ D204 LOW WATER FLOAT SWITCH BOUNCE DELAY 600
- ◆ D205 DOSE ENABLE FLOAT SWITCH BOUNCE DELAY 600
- ◆ D206 HI LEVEL ALARM FLOAT SWITCH BOUNCE DELAY 600
- ◆
- ◆ D211 ZONE 1 DOSE IN .1 GALLONS
- ◆ D212 ZONE 2 DOSE IN 0.1 GALLONS
- ◆ D213 ZONE 3 DOSE IN 0.1 GALLONS
- ◆ D214 ZONE 4 DOSE IN 0.1 GALLONS
- ◆ D219 REPEAT BACKWASH TIME INTERVAL IN .01 SEC (9000=15 MIN)
- ◆ T50 TIMER FOR D219

STANDARD INPUT REGISTER VALUES

- ◆ D221 ZONE 1 FLUSH INTERVAL PER CYCLES 45
- ◆ D222 ZONE 2 FLUSH INTERVALS D221 + TOT CYCLES PER DAY 50
- ◆ D223 ZONE 3 FLUSHINTERVALS D222 + TOT CYCLES PER DAY 55
- ◆ D224 ZONE 4 FLUSHINTERVALS D223 + TOT CYCLES PER DAY 60

◆ D229	GALLONS PER MINUTE MULTIPLIER	10
◆ D230	FILTER 1 BACKFLUSH TIME IN .1 SEC	250
◆ D231	FILTER 1 OFF TIME BEFORE FILTER 2 IN .1 SEC	50
◆ D232	FILTER 2 BACKFLUSH TIME IN .1 SEC	250
◆ D233	FILTER 2 OFF TIME BEFORE FILTER 3 IN .1 SEC	50
◆ D234	FILTER 3 BACKFLUSH TIME IN .1 SEC	250
◆ D237	ALARM OUTPUT BEEPER RATE IN .1 SEC	10
◆ D239	RUN>GPM TIME, TIME BETWEEN MEASURE AFTER FILL TIME	10
◆ D240	MULTIPLIER FOR FLOW VARIENCE LO CAT	5
◆ D241	MULTIPLIER FOR FLOW VARIENCE LO FLOW VAR	8
◆ D242	MULTIPLIER FOR FLOW VARIENCE HI FLOW VAR	12
◆ D243	MULTIPLIER FOR FLOW VARIENCE HI CAT	15
◆ D261	ZONE 1 PRESSURE IN .1 SEC	(1200=2MINUTES)
◆ D262	ZONE 2 PRESSURE IN .1 SEC	(1200=2MINUTES)
◆ D263	ZONE 3 PRESSURE IN .1 SEC	(1200=2MINUTES)
◆ D264	ZONE 4 PRESSURE IN .1 SEC	(1200=2MINUTES)
◆ D298	ZONE DOSE DELAY TIME IN SEC	15
◆ D299	SAND FILTER DELAY TIME IN SEC	10

AUTOMATIC INPUT DATA REGISTERS BY MICROPROCESSOR RUN

◆ D301	ZONE 1 FIELD SETUP VALUE
◆ D302	ZONE 2 FIELD SETUP VALUE
◆ D303	ZONE 3 FIELD SETUP VALUE
◆ D304	ZONE 4 FIELD SETUP VALUE
◆ D320	ZONE 1 LOW CAT SETUP VALUE (AUTOMATIC)
◆ D321	D320 COMPARSION
◆ D322	ZONE 1 LOW FLOW SETUP VALUE (AUTOMATIC)
◆ D323	D322 COMPARSION
◆ D324	ZONE 1 HI FLOW SETUP VALUE (AUTOMATIC)
◆ D325	D324 COMPARSION
◆ D326	ZONE 1 HI CAT SETUP VALUE (AUTOMATIC)
◆ D327	D326 COMPARSION
◆ D330-D337	ZONE 2 SAME AS D320-D327
◆ D340-D347	ZONE 3 SAME AS D320-D327
◆ D350-D357	ZONE 4 SAME AS D320-D327

CUMMULATIVE SITE DATA REGISTERS

◆ D401	ZONE 1 FLOW METER DIRECT COUNTS
◆ D402	ZONE 2 FLOW METER DIRECT COUUNTS
◆ D403	ZONE 3 FLOW METER DIRECT COUUNTS
◆ D404	ZONE 4 FLOW METER DIRECT COUUNTS
◆ D411	ZONE 1 FLOW METER COUNTS TIME D229 MULITPLIER

- ◆ D412 ZONE 2 FLOW METER COUNTS TIME D229 MULTIPLE(GPM ACTUAL)
- ◆ D413 ZONE 3 FLOW METER COUNTS TIME D229 MULTIPLE(GPM ACTUAL)
- ◆ D414 ZONE 4 FLOW METER COUNTS TIME D229 MULTIPLE(GPM ACTUAL)
- ◆ D452 ZONE 1 GALLONS IN 1000'S TOTAL
- ◆ D453 ZONE 1 GALLONS IN UNITS UP TO 999 THEN READ D452
- ◆ D454 ZONE 2 GALLONS IN 1000'S TOTAL
- ◆ D455 ZONE 2 GALLONS UP TO 999 THEN ADD TO D454
- ◆ D456 ZONE 3 GALLONS IN 1000'S TOTAL
- ◆ D457 ZONE 3 GALLONS UP TO 999 THEN ADD TO D454
- ◆ D458 ZONE 4 GALLONS IN 1000'S TOTAL
- ◆ D459 ZONE 4 GALLONS UP TO 999 THEN ADD TO D454
- ◆
- ◆ D469 ZONE 1 EVENTS-NUMBER OF CYCLES
- ◆ D470 ZONE 2 FLUSH EVENTS - NUMBER OF CYCLES
- ◆ D471 ZONE 3 FLUSH EVENTS - NUMBER OF CYCLES
- ◆ D472 ZONE 4 FLUSH EVENTS - NUMBER OF CYCLES
- ◆
- ◆ D477 DISC FILTER MANUAL BACKWASH COUNTS
- ◆ D478 DISC FILTER BACKWASH BY TIME COUNTS
- ◆ D479 DISC FILTER TOTAL BACKWASHES
- ◆
- ◆ D480 HOURS PUMP RUN TIME
- ◆ D481 MINUTES PUMP RUN TIME
- ◆ D482 SECONDS PUMP RUN TIME
- ◆
- ◆ D491 ZONE 1 COMPLETE DOSES (COUNTS)
- ◆ D492 ZONE 2 COMPLETE DOSE COUNTS
- ◆ D493 ZONE 3 COMPLETE DOSE COUNTS
- ◆ D494 ZONE 4 COMPLETE DOSE COUNTS

\\amipro\drip\dp25dr

NOTES:

X0	FLOW METER	Y0	PUMP
X1	LOW LEVEL FLOAT	Y1	FILTER 1
X2	DOSE ENABLE FLOAT	Y2	FILTER 2
X3	HIGH LEVEL FLOAT	Y3	FILTER 3
X4	SETUP MODE	Y4	ZONE 1/SAND FILTER VALVE
X5	AUTO MODE	Y5	ZONE 2 VALVE
X6	TEST MODE	Y6	ZONE 3 VALVE
X7	MANUAL MODE	Y7	ZONE 4 VALVE
X10	ZRTN DISABLE	Y10	ZONE RETURN
X11	ZONE 1 FLUSH	Y11	ALARM
X12	ZONE 2 FLUSH	Y12	FAIL HI/LO
X13	ZONE 3 FLUSH	Y13	FAIL INTIAL
X14	ZONE 4 FLUSH	Y14	POWER AVAILABLE
X15	SILENCE	Y15	HIGH WATER
X16	AUTO BACKWASH	Y16	FLOW VARIANCE
X17	ERROR TEST	Y17	CATASTROPHIC

W25 ENCLOSURE

FRONT

R.SIDE

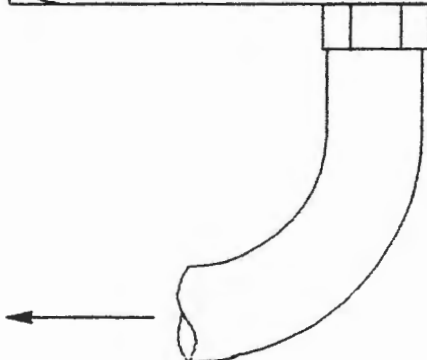
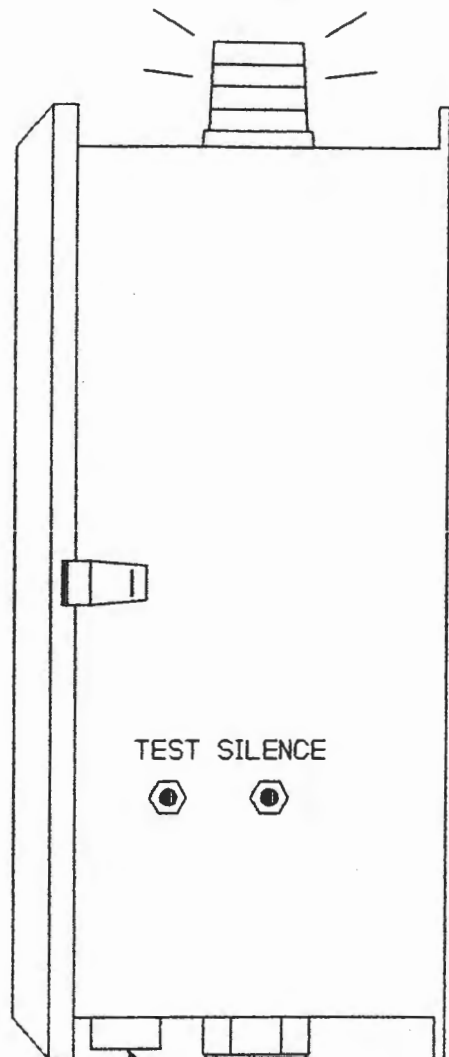
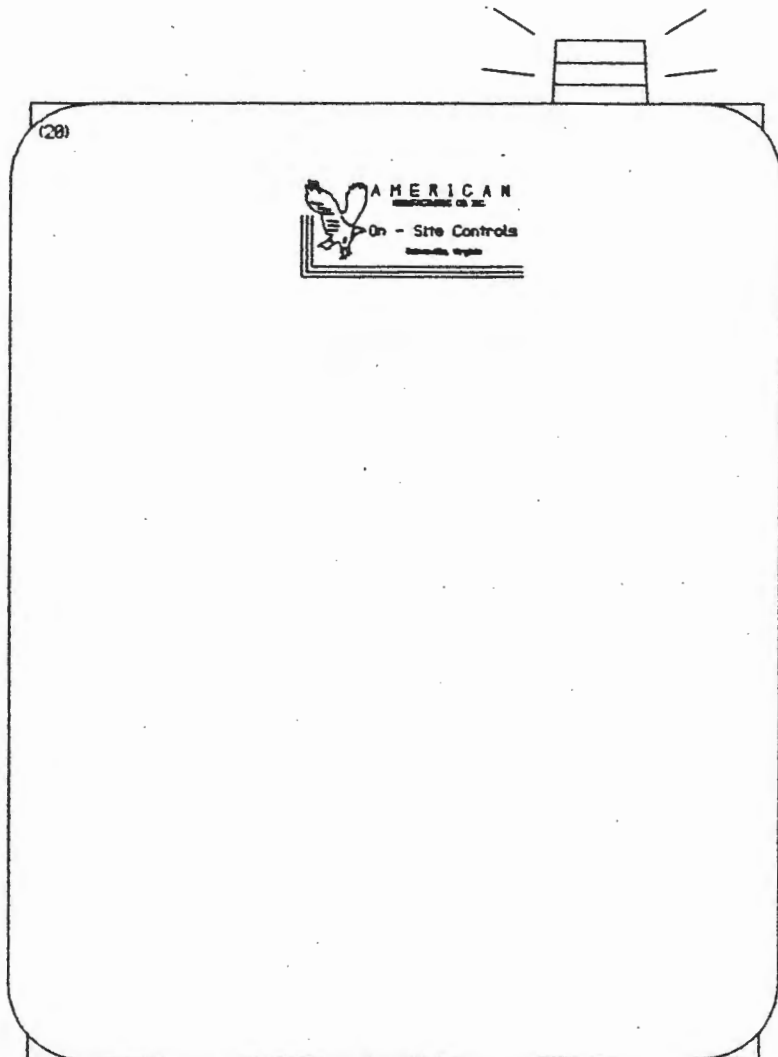

TO CENTRAL UNIT

AMERICAN MANUFACTURING CO., INC.		MODEL #DP24-SA124-AGHJLRXY	
MANASSAS, VIRGINIA 22110	B/M #B9100	DWG #X9100	DATE:7/18/95

HINGED INNER DOOR

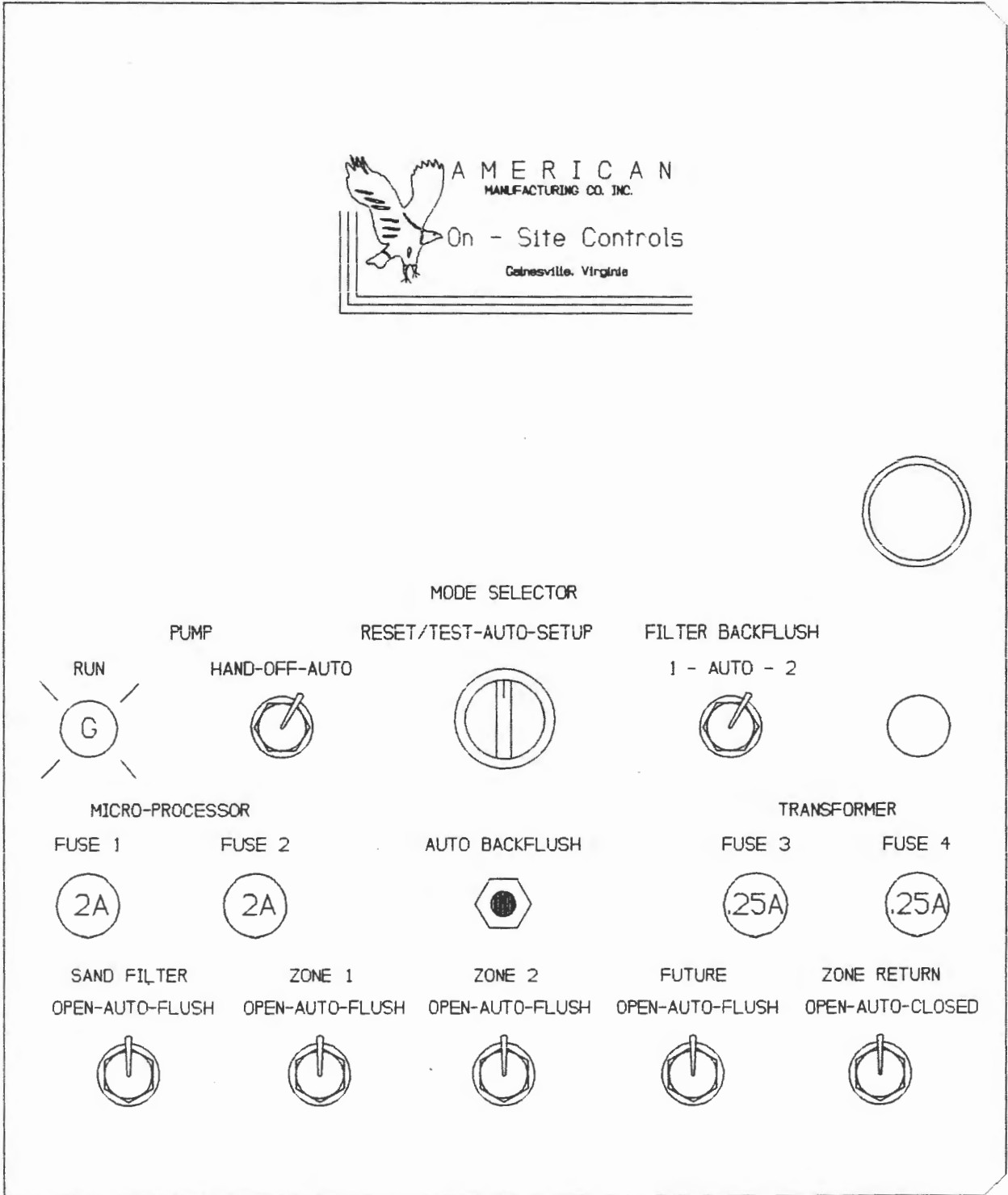
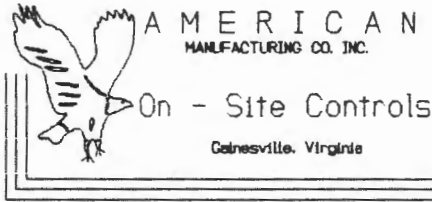

AMERICAN MANUFACTURING CO., INC.	MODEL # DP245-SA124-GHJLRXY		
MANASSAS, VIRGINIA 22110	B/M #B9101	DWG #X9101	DATE: 7/18/95

INSTALLATION SCHEMATIC DDS20 CONTROL

INSTALLATION SCHEMATIC RJ31 JACK (SINGLE LINE)

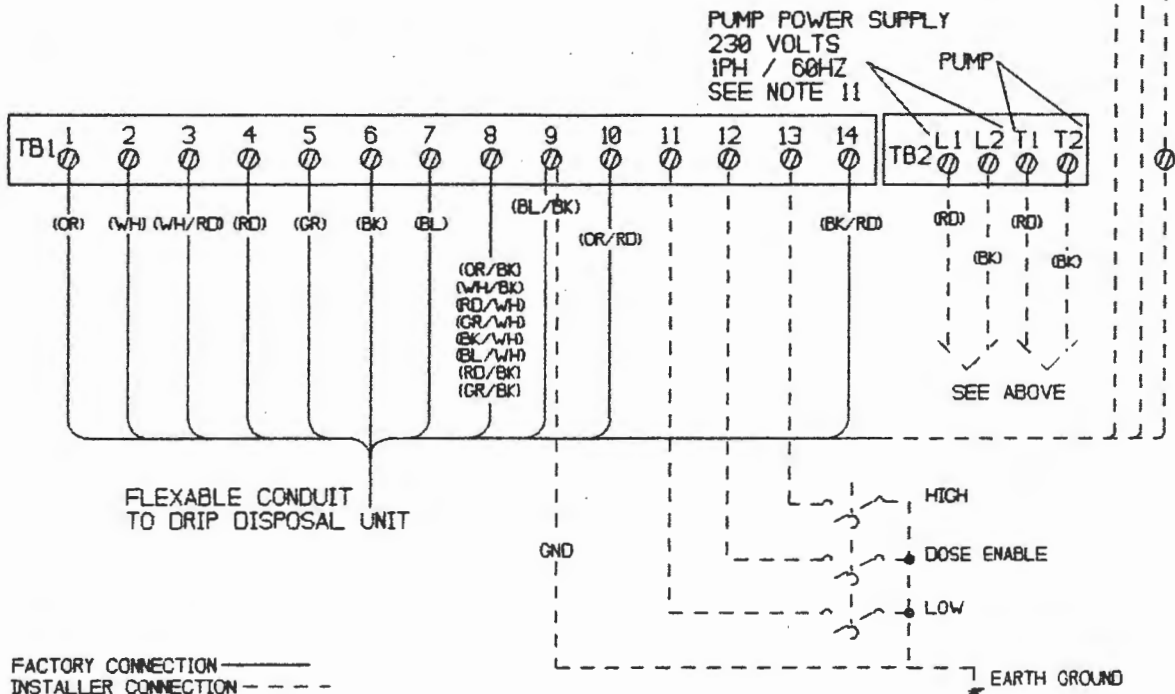
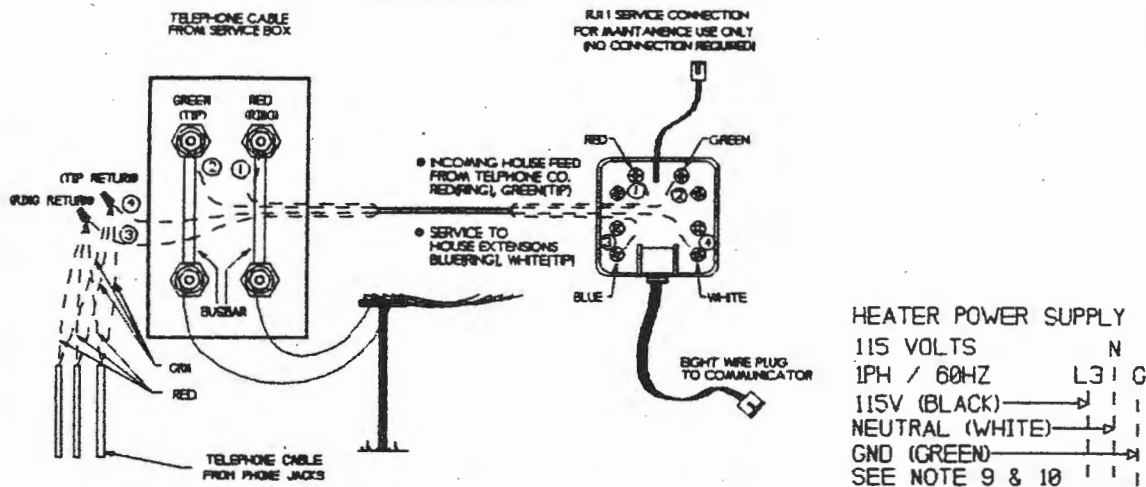

FACTORY CONNECTION ———
INSTALLER CONNECTION - - - -

INSTALLER NOTES:

- 1 AN ADDITIONAL DISCONNECT BY OTHERS REQUIRED. CONSULT NEC AND/OR LOCAL CODES.
- 2 SINGLE (1) PHASE PUMP MOTORS MUST HAVE INTEGRAL THERMAL OVERLOAD PROTECTION.
- 3 TEMPERATURE RATING OF FIELD INSTALLED COPPER CONDUCTORS MUST BE AT LEAST 140 DEGREE F. (60 DEG. C.)
- 4 TERMINAL BLOCK (TB1) TORQUE 9 IN./LBS.
- 5 TERMINAL BLOCK (TB2) TORQUE 12 IN./LBS.
- 6 (000) DENOTES BILL OF MATERIALS ITEM NO.
- 7 MUST BE CONNECTED TO SEPARATE EARTH GROUND.
- 8 MUST BE 4 CONDUCTOR WIRE IF ONLY 1 SERVICE, OTHERWISE, SEPERATE SERVICE REQUIRED.
- 9 L1 & L2 PUMP SUPPLY VOLTAGE, 2 POLE BREAKER REQUIRED.
- 10 L3 HEATER SUPPLY VOLTAGE, 1 POLE BREAKER REQUIRED.
- 11 POWER SUPPLY MUST MATCH PUMP AND TRANSFORMER VOLTAGE.

COPYRIGHT © AMERICAN MANUFACTURING COMPANY, INC.

AMERICAN MANUFACTURING CO., INC.	MODEL #DP24-SA124-AGHJLRXY		
MANASSAS, VIRGINIA 22110	B/M #B9100	DWG #X9100	DATE: 7/18/95

WIRING SCHEMATIC

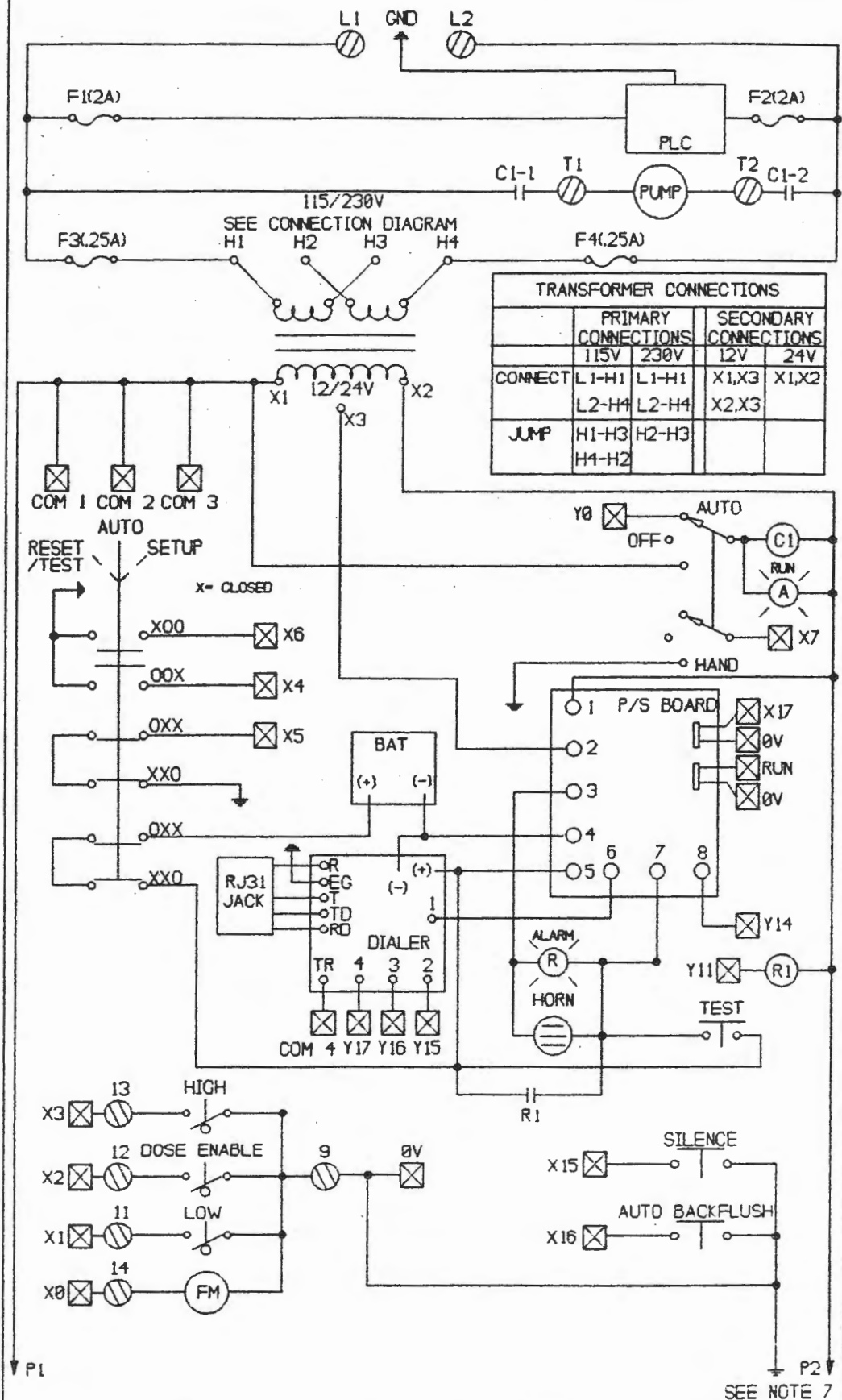

TRANSFORMER CONNECTIONS				
	PRIMARY CONNECTIONS		SECONDARY CONNECTIONS	
	115V	230V	12V	24V
CONNECT	L1-H1	L1-H1	X1,X3	X1,X2
	L2-H4	L2-H4	X2,X3	
JUMP	H1-H3	H2-H3		
	H4-H2			

AMERICAN MANUFACTURING CO., INC.	MODEL #DP24-SAL24-AGHJLRXY
MANASSAS, VIRGINIA 22110	B/M #B9100 DWG #X9100 DATE: 7/18/95

WIRING SCHEMATIC

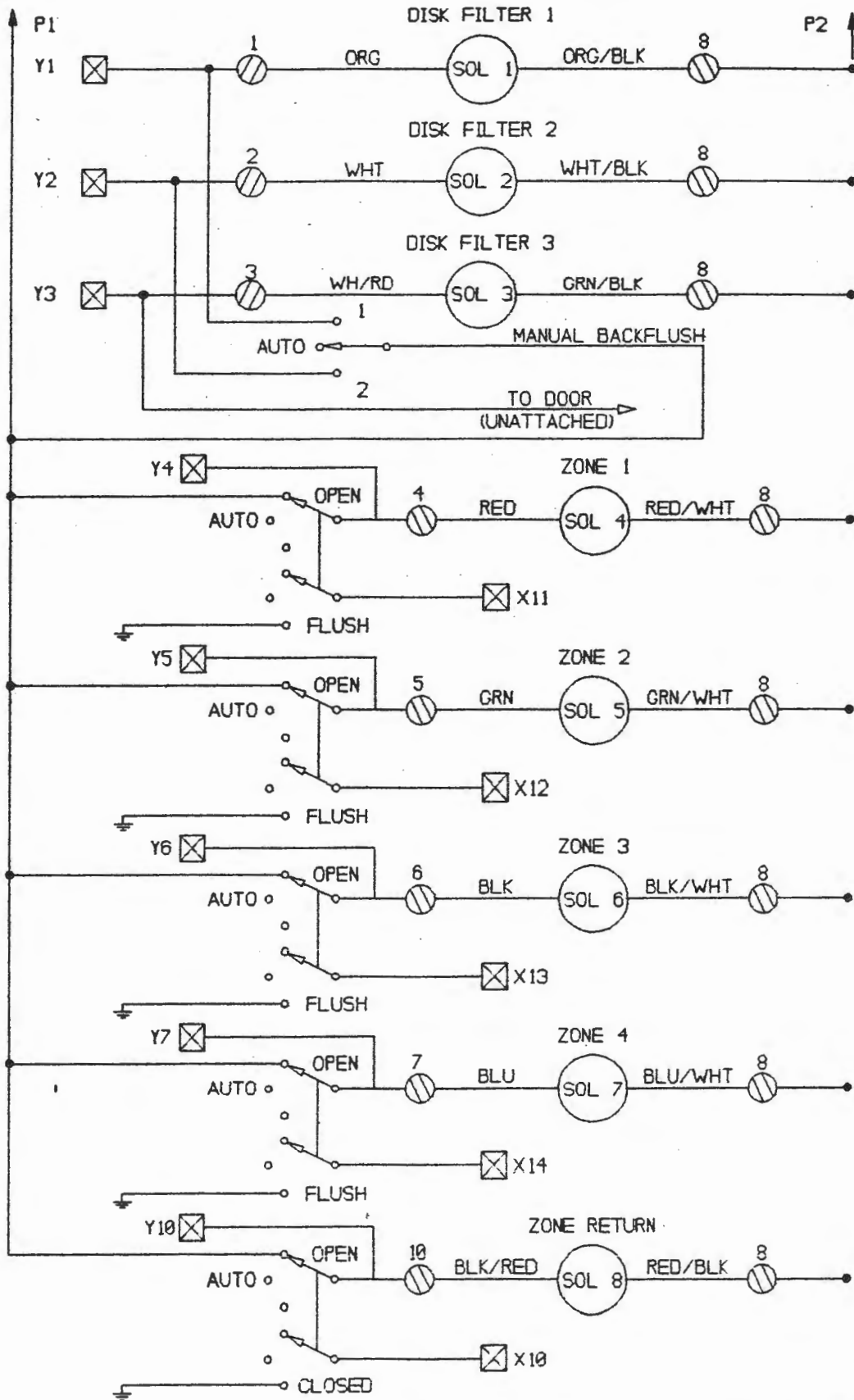

AMERICAN MANUFACTURING CO., INC.	MODEL #DP24-SA124-AGHJLRXY		
MANASSAS, VIRGINIA 22110	B/M #B9100	DWG #X9100	DATE: 7/18/95

BACKPLATE LAYOUT

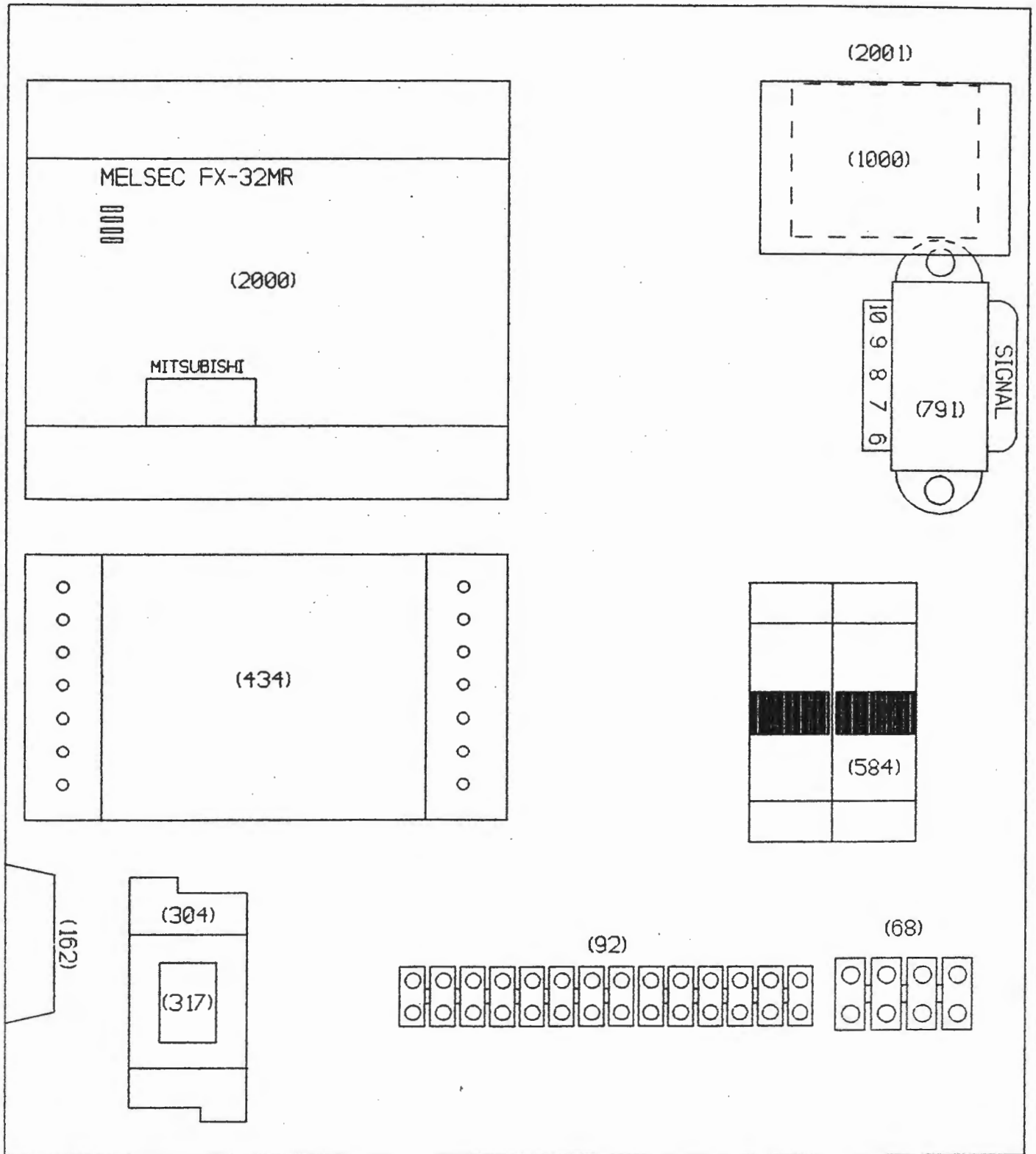

AMERICAN MANUFACTURING CO., INC.	MODEL #DP24-SA124-AGHJLXRY		
MANASSAS, VIRGINIA 22110	B/M #B9100	DWG #X9100	DATE: 7/18/95

MANASSAS, VIRGINIA 22110

AMERICAN MANUFACTURING CO., INC.

B/M #B9100

MODEL #DP24-SA127-ACHJLRXY

DWG #X9100

DATE: 7/18/95

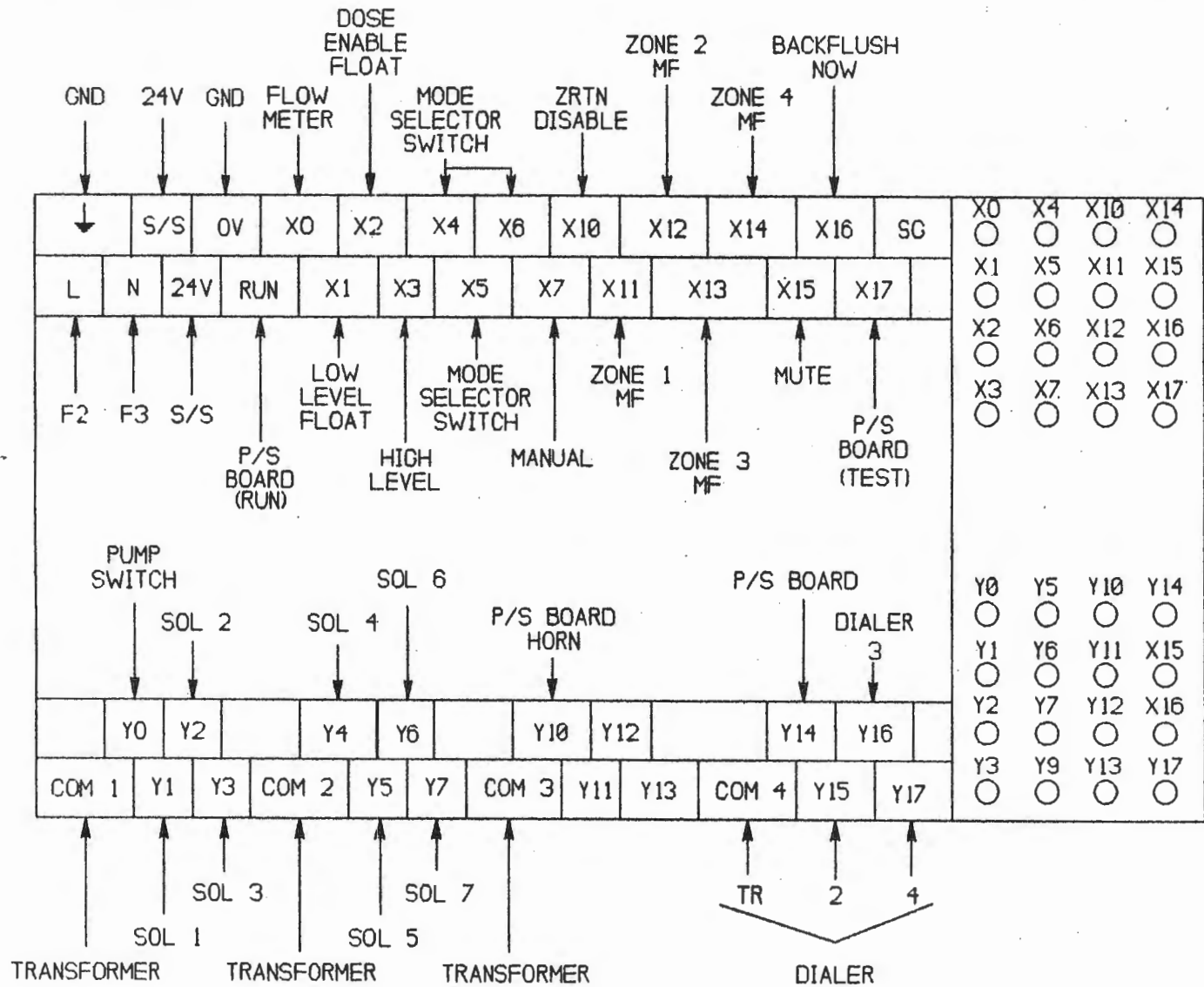

STEP 1

DIG 24" W x 36" L x 4" D AREA FOR DRP HYDRAULIC UNIT, ADJACENT TO HEADER DITCH. THERE SHALL BE A MINIMUM OF 1" POROUS MEDIUM FOR DRAINAGE.

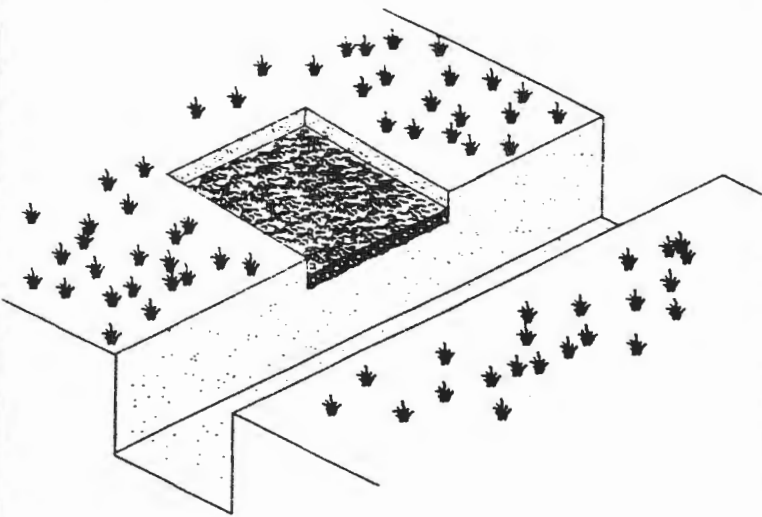

STEP 2

REMOVE HYDRAULIC UNIT FROM PACKAGING. DISCARD WOODEN PACKING MATERIAL AND PACKING SCREWS. DO NOT REMOVE OR DISCONNECT THE ELECTRICAL CABLE COILED ON UNIT!

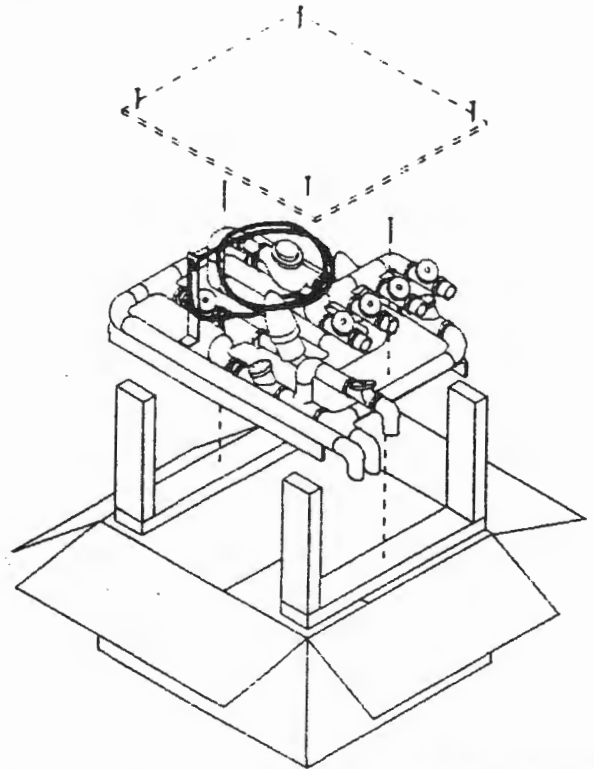

STEP 3

CENTER THE HYDRAULIC UNIT ON GRAVEL BED MAKING SURE THAT SUPPLY, RETURN, BACKFLUSH, AND ZONE SUPPLY FITTINGS WILL EXTEND OVER THE HEADER DITCH.

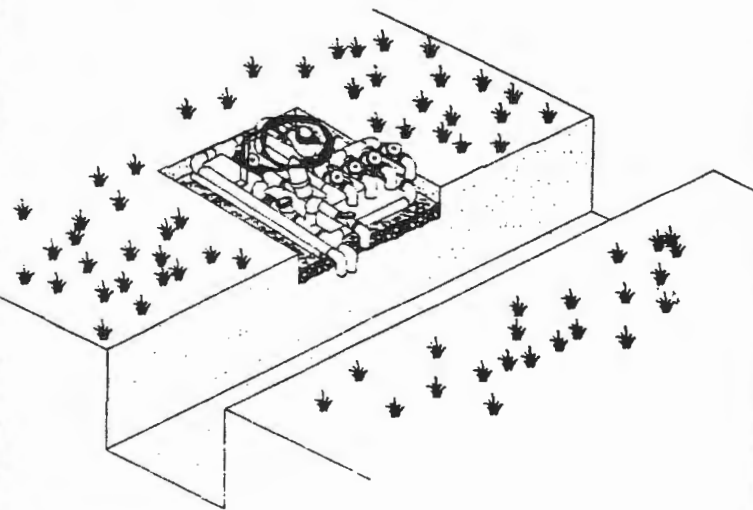

STEP 4

REMOVE ALL DIRT, STONE, AND DEBRIS FROM PIPING. SOLVENT WELD ALL FIELD FITTINGS, SUPPLY, RETURN, BACKFLUSH, AND ZONE SUPPLY, TO THE HYDRAULIC UNIT.

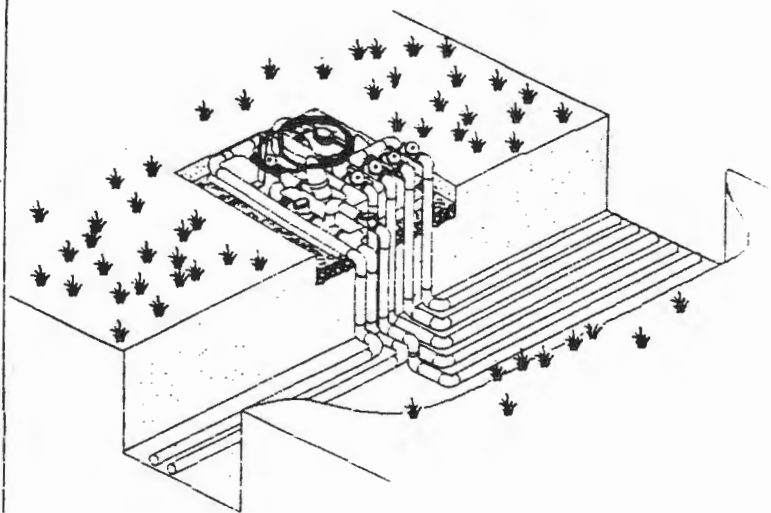

STEP 5

SET PUMP AND FLOATS.

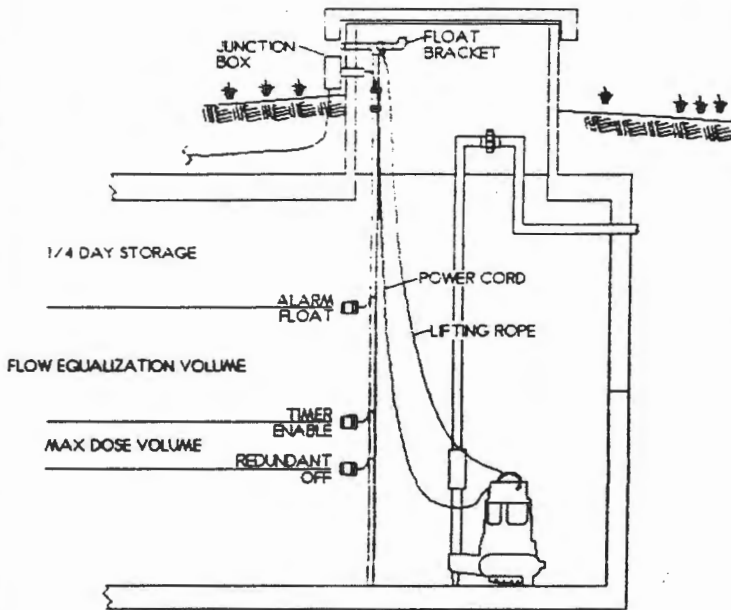

STEP 6

NOTE: CONTRACTOR WILL PROVIDE A SUITABLE ELECTRICAL DISCONNECT AND SECURELY ATTACH IT TO PANEL MOUNTING STAND.

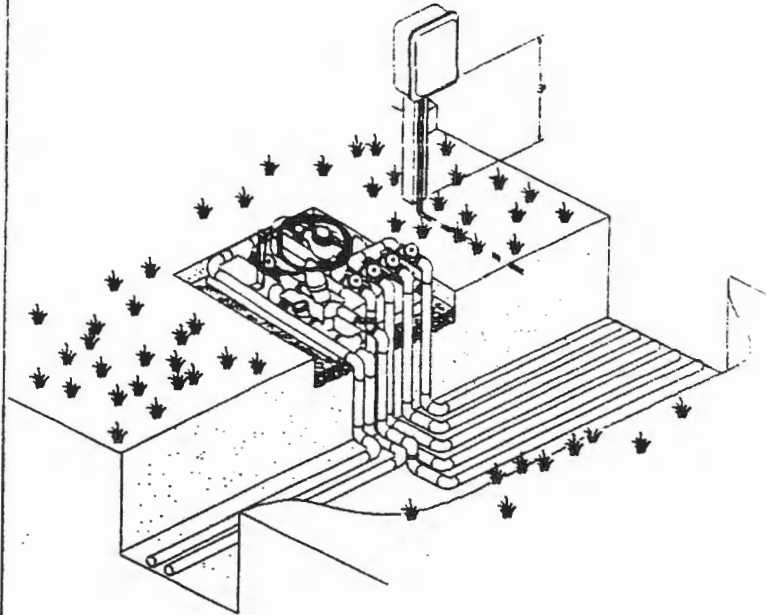

CONNECT, 4 WIRE, TELEPHONE LINE FROM HOUSEHOLD SERVICE BOX TO DRIP SYSTEM DIALER. CONNECT FLOATS AND PUMP POWER SUPPLY TO CONTROL PANEL. CONNECT PAIR OF 14 GAGE WIRES TO REMOTE ALARM IN HOUSE. INSTALL EARTH GROUND.

STEP 7

INSTALL A SCH 80 PVC CONDUIT (NOT INCLUDED) FROM CONTROL PANEL TO DRIP HYDRAULIC UNIT. MAKE SURE CONDUIT IS BURIED

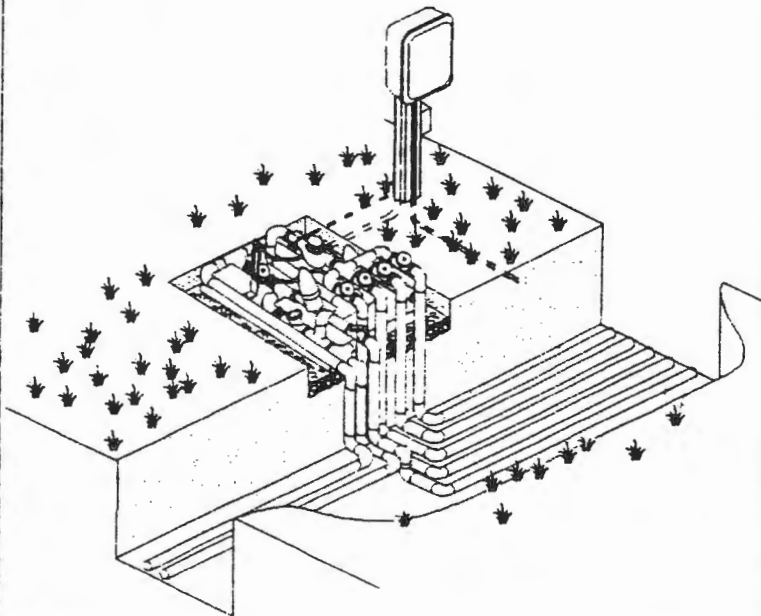

A MINIMUM OF 2' BELOW GRADE UNCOIL. DO NOT DISCONNECT ELECTRICAL CABLE ON UNIT. RUN CABLE THROUGH THE CONDUIT TO CONTROL PANEL. INSTALL A SEPERATE UF CABLE FROM DISCONNECT TO HYDRAULIC UNIT, FOR HEATER. WHEN ABOVE STEPS ARE SATISFIED, WATER TEST THE SYSTEM. CONTACT AMERICAN MFG. AT 1-800-345-3132 FOR COMPLETE SYSTEM STARTUP.

STEP 8

BACKFILL HEADER DITCH BY HAND. INSTALL VALVE BOX OVER HYDRAULIC UNIT. MOUND BACKFILL AROUND VALVE BOX UNTILL FINISH GRADE IS WITHIN 2" OF TOP OF BOX.

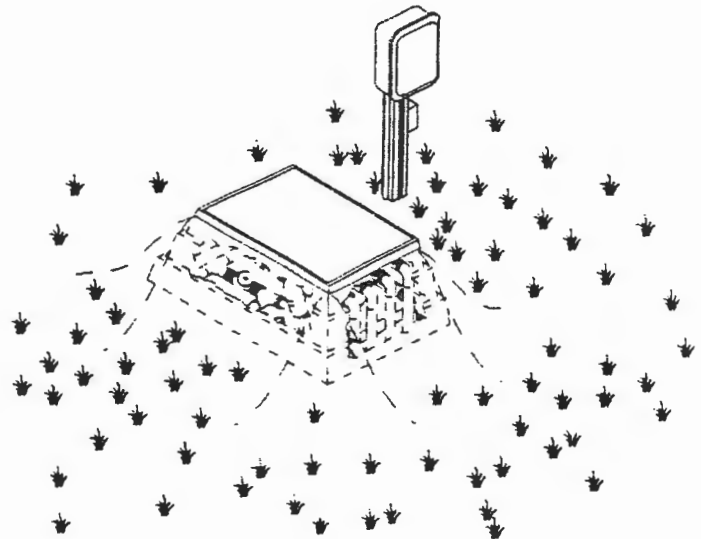

DRIP SYSTEM MODEL DP24 - 4 ZONES - STARTUP SHEET

JOB NAME GLORIOGO

DATE: 6-7-96

FILE NAME _____

FLOW METER 3629.20 *Startup Settings on 6/11/96*
all below (303-494) were good. - Begin New Reading Now)

INPUT FIELD VALUE

- D500 2 NUMBER OF ZONES IN USE
- D501 1 ALTERNATING DOSING
- D503 2 NUMBER OF DISC FILTERS IN USE
- D504 0 SAND FILTER RETURN (0=NO/1=YES)

- D200 240 Zone dose interval
- D203 _____ Sand Filter dose interval
- D211 75.0 Zone 1 dose in 0.1 gallons
- D212 75.0 Zone 2 dose in 0.1 gallons
- D213 _____ Zone 3 dose in 0.1 gallons
- D214 _____ Zone 4 dose in 0.1 gallons
- D219 9000 repeat bkwash time interval in .01 sec (3000=5 mi)
- D298 10 ZN DOSE DELAY TIME IN SEC (TYPICAL = 15)
- D299 5 SND FLTR DELAY TIME IN SEC (TYPICAL = 10)

- D301 6.0 ZONE 1 FIELD SETUP VALUE
- D302 5.5 ZONE 2 FIELD SETUP VALUE
- D303 _____ ZONE 3 FIELD SETUP VALUE
- D304 _____ ZONE 4 FIELD SETUP VALUE
- D452 _____ ZONE 1 GALLONS IN 1000'S TOTAL
- D453 _____ ZONE 1 GAL. IN UP TO 999 THEN READ D452
- D454 _____ ZONE 2 GALLONS IN 1000'S TOTAL
- D455 _____ ZONE 2 GAL. UP TO 999 THEN ADD TO D454
- D456 _____ ZONE 3 GALLONS IN 1000'S TOTAL
- D457 _____ ZONE 3 GAL. UP TO 999 THEN ADD TO D454
- D458 _____ ZONE 4 GALLONS IN 1000'S TOTAL
- D459 _____ ZONE 4 GAL. UP TO 999 THEN ADD TO D454
- D469 _____ ZONE 1 FLUSH EVENTS-NUMBER OF CYCLE
- D470 _____ ZONE 2 FLUSH EVENTS - NUMBER OF CYCLE
- D471 _____ ZONE 3 FLUSH EVENTS - NUMBER OF CYCLE
- D472 _____ ZONE 4 FLUSH EVENTS - NUMBER OF CYCLE
- D477 _____ DISC FILTER MANUAL BACKWASH COUNTS
- D478 _____ DISC FILTER BACKWASH BY TIME COUNTS
- D479 _____ DISC FILTER TOTAL BACKWASHES
- D480 _____ HOURS PUMP RUN TIME
- D481 _____ MINUTES PUMP RUN TIME
- D482 _____ SECONDS PUMP RUN TIME
- D491 _____ ZONE 1 COMPLETE DOSE COUNTS
- D492 _____ ZONE 2 COMPLETE DOSE COUNTS
- D493 _____ ZONE 3 COMPLETE DOSE COUNTS
- D494 _____ ZONE 4 COMPLETE DOSE COUNTS

LETTER OF AGREEMENT FOR MONITORING SERVICE

The controller, inside the System, is connected to a central service computer by a telephone line serving your house that is required to be connected to the System. The communicator will take precedence on the telephone service. This means that if communication from the unit is initialized, all telephone service and that line will be terminated until the communicator relinquishes the line. Normal telephone communications from the house will be restored when the controller completes its transmission. If any of the below conditions occur, the controller will automatically telephone the manufacturers central service computer on any of the following conditions:

- | | |
|--------------------|-------------------------------|
| High Water | Power Out |
| 20 % Flow Variance | Restoration of all Conditions |
| 50 % Flow Variance | |

The owner understands and will hold the contractor and manufacturer harmless for the controller which is built into the System and provides these functions:

The owner understands that it is a condition of the permit that the manufacturer is to monitor the above conditions 24 hours a day to prevent the possibility of system problems due to the nature of these conditions and that for the first three years of use American shall maintain a log of all flow variations which deviate by 20% or more from the design flow. The log shall include the following minimum information: System location, percent flow variation observed, cause of the flow variation, and duration of flow variation. Said log shall be reported to the health department on a quarterly basis and shall be provided by the 15th of the month following the end of the quarter. The log shall be available to the health department within 5 business days upon request.

The Owner shall provide American with such access to the property and system as is reasonably necessary for American to comply with the terms of this Agreement.

As soon as the central service computer is notified, a printout stating which condition occurred and the nature of the condition and where the system is located and will send the maintenance staff into action. First they will attempt to contact the owner of the system to see if they can suggest what has created the condition. If they are unable to solve the problem over the telephone, they can then dispatch a technician. Even in the event of a power failure, the system is designed to provide At least an additional 1/4 day of capacity. Once the condition has been corrected, a restoration message will be printed out by the central service computer showing that the system is functioning normal again,

American Manufacturing Company, Inc.
5517 Wellington Road
Gainesville, Va 22110



Representative

Date: 6-2-96

OWNER: TON GLORIOSO
ADDRESS: _____

By: _____

Date: 6-2-96 Serial No.: 4843

namipro\dripl\servagre