

Bureau of Environmental Health
 8930 Stanford Boulevard, Columbia, MD 21045
 Main: 410-313-2640 | Fax: 410-313-2648
 TDD 410-313-2323 | Toll Free 1-866-313-6300
www.hchealth.org
 Facebook: www.facebook.com/hocohealth

Maura J. Rossman, M.D., Health Officer

RECEIPT DATE: _____ **ONSITE SEWAGE DISPOSAL SYSTEM** P 558723

APPROVAL DATE: 7/27/16 **PERMIT:** **REPAIR** A 558066

PROPERTY ADDRESS: 7514 Browns Bridge Rd, Highland - 20777

SUBDIVISION: Greenwood Farms LOT: 10 TAX ID: 5368049

CONTRACTOR: Hatfields Equip. + Dedie. EMAIL: _____

CONTRACTOR ADDRESS: _____ PHONE: (410)984-0047

PROPERTY OWNER: Jeffrey Van Den Broek EMAIL: _____

OWNER ADDRESS: 7514 Browns Bridge Rd. PHONE: _____

SEPTIC TANK SIZE (GALLONS): _____ PUMP CHAMBER CAPACITY (GALLONS): _____ PUMP SIZE: _____

NUMBER OF BEDROOMS: _____ HOUSE SQ. FT. _____ APPLICATION RATE: _____

DISTRIBUTION SYSTEM: GRAVITY FED LOW PRESSURE DOSED

TRENCHES:	LINEAR FEET REQUIRED: _____	INLET DEPTH: _____
	TRENCH WIDTH: _____	MAXIMUM BOTTOM DEPTH: _____
	MINIMUM SPACE BETWEEN TRENCHES: _____	EFFECTIVE AREA BEGINNING DEPTH: _____
LOCATION:	TO BE STAKED BY SANITARIAN DURING PRE-CONSTRUCTION INSPECTION.	
NOTES:		

ISSUED BY: _____ ISSUE DATE: _____ EXPIRATION DATE: _____

- NOTE: CONTRACTOR MUST SCHEDULE A PRE-CONSTRUCTION INSPECTION PRIOR TO BEGINNING ANY INSTALLATION**
- NOTE: CONTRACTOR MUST SCHEDULE AN INSPECTION AND GAIN APPROVAL OF ALL COMPONENTS PRIOR TO COVERING
- NOTE: STONE MUST BE APPROVED BY HEALTH DEPARTMENT AND GRAVEL TICKET MUST BE AVAILABLE FOR REVIEW.
- NOTE: WATERTIGHT SEPTIC TANKS REQUIRED
- NOTE: ALL PARTS OF SEPTIC SYSTEM SHALL BE AT LEAST 100 FEET DOWNGRADIENT FROM ANY WATER WELL
- NOTE: MANHOLE RISERS REQUIRED ON ALL SEPTIC TANKS AND PUMP CHAMBERS
- NOTE: AN ELECTRICAL PERMIT IS REQUIRED FOR INSTALLATION OF ANY ELECTRICAL COMPONENTS OF THE SYSTEM**
 ELECTRICAL PERMIT ISSUED E _____
- NOTE: THE HCHD DOES NOT WARRANT ANY SYSTEM AND CANNOT GUARANTEE THE PERFORMANCE OF THIS SYSTEM AS DESIGNED. BY ACCEPTING THIS PERMIT, THE OWNER AND/OR APPLICANT ACKNOWLEDGE THAT THE SPECIFICATIONS DETAILED IN THIS DESIGN ARE ONE POSSIBLE OPTION AND THAT THE HCHD WILL REVIEW OTHER PROPOSALS. YOU HAVE THE OPTION TO SEEK THE ADVICE OF A QUALIFIED DESIGN CONSULTANT OR PROFESSIONAL ENGINEER FOR FURTHER GUIDANCE.**
- NOTE: MDE RECOMMENDS SEPTIC TANKS, BAT, AND OTHER PRETREATMENT UNITS BE PUMPED AT A FREQUENCY ADEQUATE TO ENSURE THAT SOLIDS ARE NOT DISCHARGED TO THE DISPOSAL AREA

NEITHER THE HOWARD COUNTY COUNCIL NOR THE HEALTH DEPARTMENT IS RESPONSIBLE FOR THE SUCCESSFUL OPERATION OF ANY SYSTEM.
PERMITTEE RESPONSIBLE FOR OBTAINING FINAL APPROVAL ON THIS PERMIT.
CALL 410-313-1771 TO SCHEDULE INSPECTIONS.

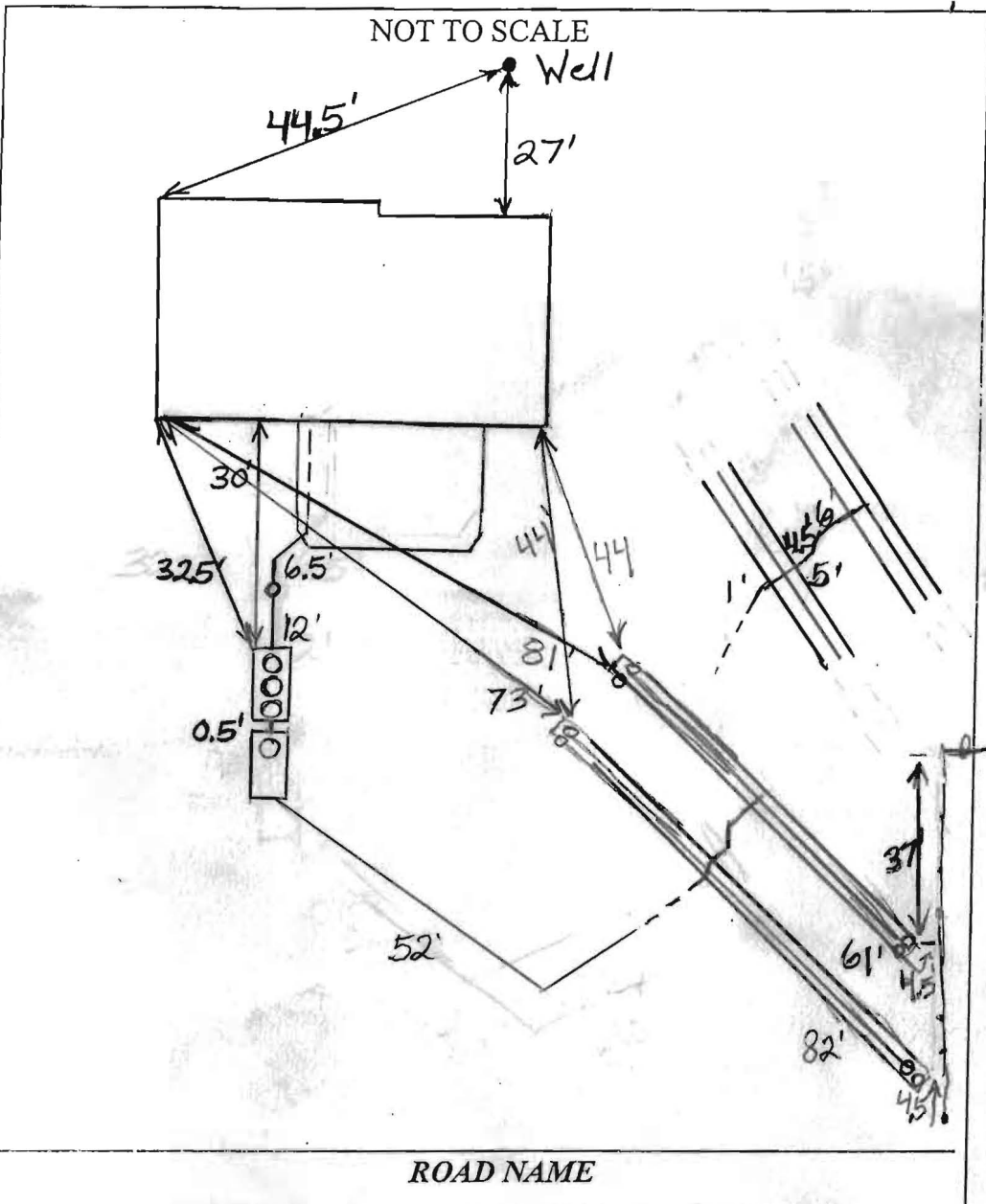

TRENCH/DRAINFIELD DATA		
WIDTH	INLET	BOTTOM
3'	3'	7'
NUMBER OF TRENCHES		2
TOTAL LENGTH		143'
ABSORPTION AREA		429' Sidewall
DISTRIBUTION BOX LEVEL		N/A
DISTRIBUTION BOX BAFFLE		N/A
DISTRIBUTION BOX PORT		N/A

SEPTIC TANK DATA	
SEPTIC TANK I LEVEL	Yes
MANUFACTURER	Norweco
CAPACITY	1300 GAL
SEAM LOC	Top
TANK LID DEPTH	2'-3'
BAFFLES	No
BAFFLE FILTER	N/A
MANHOLE LOC	Front Middle Rear
6" PORT LOC	None
WATERTIGHT TEST	No
SLOTTED	N/A
DATE ON LID	1/3/2016
PUMP/SEPTIC TANK LEVEL	Yes
MANUFACTURER	Babylon
CAPACITY	1500 GAL
SEAM LOC	Top
TANK LID DEPTH	1.5'-2.5'
BAFFLES	No
BAFFLE FILTER	No
MANHOLE LOC	Front
6" PORT LOC	None
WATERTIGHT TEST	No
SLOTTED	No
DATE ON LID	Dry

PRE-CONSTRUCTION:
 4/15/2016 Trenches tentatively laid out to make sure there is adequate room. There is probably enough room for one repair (BB)
 6/10/2016 Trench locations painted out in backyard. Install tanks further away from and downhill of existing tank. (BB)
 6/14/2016 LPD specs determined. (BB)

INSTALLATION:
 6/13/2016 Tanks set. House connection made. (BB)
 6/14/2016 Trenches installed. Need approval from Norweco and pump and alarm test. (BB)
 6/16/2016 Received approval from Norweco. Need pump and alarm test. (BB)
 7/27/2016 Pumps and alarm working. at least 2' of head in all turn-ups. (BB)

FINAL INSPECTOR B. Baper DATE OF APPROVAL 7/27/2016

Jeff-

Finished
Repair

Back River Pre-Cast, LLC

PO BOX 329
Glyndon, MD 21071
Phone # 410-833-3394
Fax # 410-833-4116

Letter of Certification

This is to certify that the Norweco Singlair TNT 600 GPD Septic Tank installed at 7514 Brown Bridge Rd., Highland, MD 20777 June 13, 2016 was installed according to the manufacture's specifications.

Installer: Jeff Reiter

Property Owner: Jeff Van Den Broek

Permit #

THIS CERTIFICATION IS FOR INSTALLATION ONLY. THE 5-YEAR OPERATIONS & MAINTENANCE AGREEMENT FROM DATE OF INSTALLATION WILL ONLY GO INTO EFFECT AFTER BACK RIVER PRE-CAST, LLC RECEIVES FINAL AND FULL PAYMENT FOR THE SYSTEM.



MATTHEW GECKLE

Vice-President

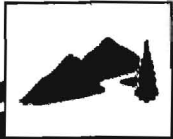

CANAAN VALLEY INSTITUTE

May 17, 2016

Jeffrey Vandebroek
7514 Browns Bridge Road
Highland, MD 20777

RE: FY 2016 Howard County Bay Restoration Fund OSDS Upgrade Program

Dear Mr. Vandebroek:

Thank you for your application to participate in the Howard County Bay Restoration Fund OSDS Upgrade Program. The Howard County Health Department has verified that your existing septic system is failing and in need of repair. Based on your 2014 income tax return form, you are eligible to receive funding to cover **100%** of the cost to upgrade your system to one of the MDE approved BAT units listed below. The approved price includes the cost of the unit, installation of the unit, and 5 years of operation and maintenance. The price does not include the cost of permits.

<u>System</u>	<u>Vendor</u>	<u>Contact</u>	<u>Phone</u>
Orengo (Advantex AX20)	Atlantic Solutions	Robert Johnson	877-214-9283
HOOT 600 BNR	Mayer Bros, Inc	Nancy Mayer	410-796-1434
Norweco Singlair TNT	Back River Precast LLC	Matthew Geckle	410-833-3394
SeptiTech	Maryland Concrete, Inc	Rodney Glace	443-491-3598

In order to receive your OSDS upgrade, **you MUST follow these steps:**

1. **Sign this letter** on the bottom of page 2 **and return it** in the envelope provided within **2 weeks of the date of this letter.**
2. File a septic repair permit application with the Howard County Health Department **within 2 weeks of the date of this letter.** The permit application fee is \$396.00 (\$165 for tank approval only).
3. Obtain the Agreement and Easement for Installation of Best Available Technology Systems with Bay Restoration Funds from the Howard County Health Department; have it signed by a Howard County Health Department Bureau Director or Designee. Then take it to the Circuit Court and have it recorded in Land Records **within 2 weeks of the date of this letter.**
4. Prepare your property and schedule installation of the system. The system must be installed **within 6 weeks of the date the Agreement and Easement is recorded.**

494 RiverStone Road | Davis, WV 26260
Phone: (304) 259.4739 or (800) 922.3601 | Fax: (304) 259.4759
www.canaanvi.org

The system vendor may provide a contractor to install your BAT unit. CVI will provide payment directly to the vendor. The vendor may also require proof of insurance from your contractor.

If your system is not installed within the 8 week timeframe listed in the steps on page 1, the funds may be released and used elsewhere. If you cannot complete installation in within this timeframe, please contact me to request an extension. Please note that failure to request an extension may result in termination of your grant and your system must be installed no later than June 27, 2016 in order to retain your funding.

For more information on septic repair permitting, contact:

Jeff Williams
Program Supervisor, Well and Septic
410-313-1771

Please sign and return this original letter and keep a copy for your records. If you have any questions, please contact me at 304-940-3443 or by email at kristin.mielcarek@canaanvi.org.

Sincerely,

Kristin Mielcarek, Watershed Circuit Rider

Accepted by: Jeffrey Vandebroek, Property Owner

I have read and agree to the conditions of this Agreement Letter.

Signature

Date

494 RiverStone Road | Davis, WV 26260
Phone: (304) 259.4739 or (800) 922.3601 | Fax: (304) 259.4759
www.canaanvi.org



Bureau of Environmental Health

8930 Stanford Boulevard, Columbia, MD 21045

Main: 410-313-2640 | Fax: 410-313-2648

TDD 410-313-2323 | Toll Free 1-866-313-6300

www.hchealth.org

Facebook: www.facebook.com/hocohealth

Twitter: [HowardCoHealthDep](https://twitter.com/HowardCoHealthDep)

Maura J. Rossman, M.D., Health Officer

AGREEMENT AND EASEMENT FOR INSTALLATION OF BEST AVAILABLE TECHNOLOGY SYSTEMS WITH BAY RESTORATION FUNDS.

THIS AGREEMENT is made this ____ day of _____, among _____, hereinafter referred to as "Owner," the Howard County Health Department hereinafter collectively referred to as the "County," and the Department of the Environment, hereinafter referred to as the "Department."

WHEREAS, Owner owns a tract of land located on _____, in the Election District of Howard County, Maryland, and the deed to same is recorded among the Land Records of Howard County, Maryland, in Columbia and in Liber _____ Folio _____.

WHEREAS, the Bay Restoration Fund (BRF) may provide a grant for the cost attributable to upgrading an onsite sewage disposal system to the Best Available Technology (BAT) for the removal of nitrogen.

WHEREAS, the BRF may also provide a grant for the cost difference between a traditional onsite sewage disposal system and a system that utilizes the BAT for the removal of nitrogen.

WHEREAS, Owner understands that participation in the Bay Restoration Fund is voluntary.

NOW, THEREFORE, the parties hereto agree as follows:

- A. Owner hereby grants to the Department and the County the right to enter upon the property at any reasonable time for access to the system to make periodic inspections and the Owner agrees to provide any information and data requested and needed by the Department to develop accurate and thorough test results.
- B. Owner acknowledges and agrees that a MDE certified and manufacturer-approved installer will install the BAT system.
- C. Owner acknowledges and agrees the manufacturer or manufacturer's authorized service provider will provide for Operation and Maintenance of the BAT for a period of 5 years as a condition of sale of the BAT. After the initial 5 year period an Operation and Maintenance contract with a certified service provider must be maintained in perpetuity by the property owner.
- D. Owner acknowledges and agrees that the manufacturer appointed Operation and Maintenance provider will have access to the BAT system at all times.
- E. Owner acknowledges and agrees that the manufacturer or manufacturer's authorized service provider will have access to sample the effluent of the BAT system. Owner acknowledges and agrees that the proposed installation of a BAT system funded by the BRF is voluntary. Owner agrees that there shall be no liability on the part of the County or Department to Owner if this BAT system fails, and that the County and the Department do not warrant or guarantee that the BAT system will adequately or properly function.
- F. Owner acknowledges and agrees that neither the County nor the Department nor any of its

agents or employees, either officially or individually, underwrites the operation of any system approved by them.

- G. The Owner will devote such care and effort to the maintenance of the BAT system so that any malfunction is not the result of poor maintenance, faulty operation, or neglect.
- H. The Canaan Valley Institute agrees to grant up to \$_____ toward the cost of installation of the BAT system, and financial responsibility is limited to this amount. Operating costs will be at the Owners expense.
- I. The Owner acknowledges that the BRF grant can only be used for that portion of the OSDS attributable to (BAT) for the removal of nitrogen.
- J. Owner acknowledges in the event the total project cost is greater than \$25,000 the proposal will have to be approved by the Maryland State Board of Public Works.
- K. The Owner agrees to contact both the Water Management Administration, On-Site Systems Division of the Wastewater Permits Program and the County at least forty-eight (48) hours prior to system installation, so that the Department has the opportunity to be present at the time of installation or thereafter for inspection.
- L. The Owner must install BAT system according to the manufacturer recommended plans and specifications approved by the Department.
- M. The Owner agrees and acknowledges that if installation deviates substantially from the approved plans or changes such that performance of the system is compromised or reduced, BRF funding will not be provided.
- N. This agreement shall run with the land and binds the Owner, his heirs, successors, assigns. Owner further agrees that he shall inform in writing any purchaser or lessee of the property that the system may require maintenance or other attention. The Owner agrees to record this agreement in the land records of Howard County.
- O. This agreement shall not be construed to limit any authority of the Department to protect the public health, safety or comfort or to issue any other orders to take any other action that is now or may hereafter be within its authority.
- P. This agreement may be voided at the discretion of the Department if the system construction is not completed within six (6) months of the effective date of this agreement.
- Q. This agreement contains the entire agreement and understanding between the County and the Owner and the Department. There are no additional terms other than as contained in this agreement. This agreement may not be modified except in writing signed by each of the parties or by their authorized representatives.
- R. The laws of the State of Maryland govern the provisions of all transactions pursuant to this agreement.

IN WITNESS WHEREOF, the parties have signed and sealed this agreement on the date indicated above.

DATE: _____

Owner

DATE: _____

Howard County Health Department

3/14/60 - ck out
inside 11:00

PERMIT

SEWAGE DISPOSAL SYSTEM

P 02042

A 00600

MARYLAND STATE DEPARTMENT OF HEALTH
HOWARD COUNTY

ELLCOTT CITY

DISTRICT 5

DATE 3/12/60

INDEXED

William T. Cumberland

IS PERMITTED TO INSTALL ALTER

ADDRESS Brown's Bridge Rd.

PHONE Atlas 6-2403

A SEWAGE DISPOSAL SYSTEM LOCATED AT

SUBDIVISION Greenwood Farms

ROAD ⁷⁵⁷⁴ Brown Bridge

LOT 10

PROPERTY OWNER William T. Cumberland John Francis Springer

ADDRESS

SPECIFICATIONS

DRAIN FIELD DEPTH FEET, BOTTOM AREA 580 SQ. FT.

SEEPAGE PITS ABSORBENT SIDE-WALL AREA SQ. FT.

SEPTIC TANK CAPACITY 750 GALLONS

FOR GARBAGE GRINDER, INCREASE DISPOSAL AREA 22% & TANK CAPACITY 50%

OTHER System must be installed in area that passed perc. test.

PLANS APPROVED BY Raymond Hodges

DATE 3/19/59

FILL SEPTIC TANK AND DISTRIBUTION BOX WITH WATER BEFORE CALLING FOR AN INSPECTION. COVER NO WORK UNTIL INSPECTED AND APPROVED.

NEITHER THE HOWARD COUNTY COMMISSIONERS NOR THE HEALTH DEPARTMENT IS RESPONSIBLE FOR THE SUCCESSFUL OPERATION OF ANY SYSTEM.

ELDG. PERMIT SIGNED
AND RETURNED 8/2/65
Louis H. Gilmer
enclosed expecting copy not
release holder

ELDG. PERMIT SIGNED
AND RETURNED 8/15/66
Louis H. Gilmer

000600

