

Bureau of Environmental Health
 8930 Stanford Blvd. Columbia, MD 21045
 (410) 313-2640 Fax (410) 313-2648
 TDD (410) 313-2323 Toll Free 1-866-313-6300
 website: www.hchealth.org

Maura J. Rossman, M.D., Health Officer

RECEIPT DATE: 11/13/14
 INSTALLATION APPROVAL DATE: 4/28/2015

ONSITE SEWAGE DISPOSAL SYSTEM

P 555315
 A _____

PERMIT

Repair- BRF

PROPERTY ADDRESS: 8549 Old Frederick Road
 SUBDIVISION: _____ LOT: _____ TAX ID: 02-252368
 CONTRACTOR: Fogle's Septic Clean Inc. EMAIL: kevin@foglesinc.com
 CONTRACTOR ADDRESS: 580 Obrecht Road, Sykesville, MD 21784 PHONE: 410-795-5670
 PROPERTY OWNER: Nicole Jenson EMAIL: _____
 OWNER ADDRESS: 8549 Old Frederick Road, Ellicott City, MD 21043 PHONE: 410-751-3510

SEPTIC TANK SIZE (GALLONS): _____
 BAT UNIT: Norweco STATIC HEAD (FEET): N/A
 NUMBER OF BEDROOMS: 3 HOUSE SQ. FT. <3501 APPLICATION RATE: 1.2
 DISTRIBUTION SYSTEM: GRAVITY FED LOW PRESSURE DOSED

TRENCHES:	LINEAR FEET REQUIRED: <u>62'</u>	INLET DEPTH: <u>4'</u>
	TRENCH WIDTH: <u>2'</u>	MAXIMUM BOTTOM DEPTH: <u>10'</u>
	MINIMUM SPACE BETWEEN TRENCHES: <u>N/A</u>	EFFECTIVE AREA BEGINNING DEPTH: <u>5.5'</u>
	LOCATION: Install tank 10' off highest area closest to house.	
NOTES:	Install 1 x 62' trench above existing failed trench. Any improvement to house w/ BR addition will require more trench.	

ISSUED BY: Kevin Wolf ISSUE DATE: 12/3/14 EXPIRATION DATE: 12/3/15

- NOTE: CONTRACTOR MUST SCHEDULE A PRE-CONSTRUCTION INSPECTION PRIOR TO BEGINNING ANY INSTALLATION
- NOTE: CONTRACTOR MUST SCHEDULE AN INSPECTION AND GAIN APPROVAL OF ALL COMPONENTS PRIOR TO COVERING
- NOTE: STONE MUST BE APPROVED BY HEALTH DEPARTMENT AND GRAVEL TICKET MUST BE AVAILABLE FOR REVIEW.
- NOTE: WATERTIGHT SEPTIC TANKS REQUIRED
- NOTE: ALL PARTS OF SEPTIC SYSTEM SHALL BE AT LEAST 100 FEET DOWNGRADIENT FROM ANY WATER WELL
- NOTE: MANHOLE RISERS REQUIRED ON ALL SEPTIC TANKS AND PUMP CHAMBERS
- NOTE: AN ELECTRICAL PERMIT IS REQUIRED FOR INSTALLATION OF ANY ELECTRICAL COMPONENTS OF THE SYSTEM

**NEITHER THE HOWARD COUNTY COUNCIL NOR THE HEALTH DEPARTMENT IS RESPONSIBLE FOR THE SUCCESSFUL OPERATION OF ANY SYSTEM.
 PERMITTEE RESPONSIBLE FOR OBTAINING FINAL APPROVAL ON THIS PERMIT.
 CALL 410-313-1771 TO SCHEDULE INSPECTIONS.**

NOT TO SCALE

48' to Dist. ← Box

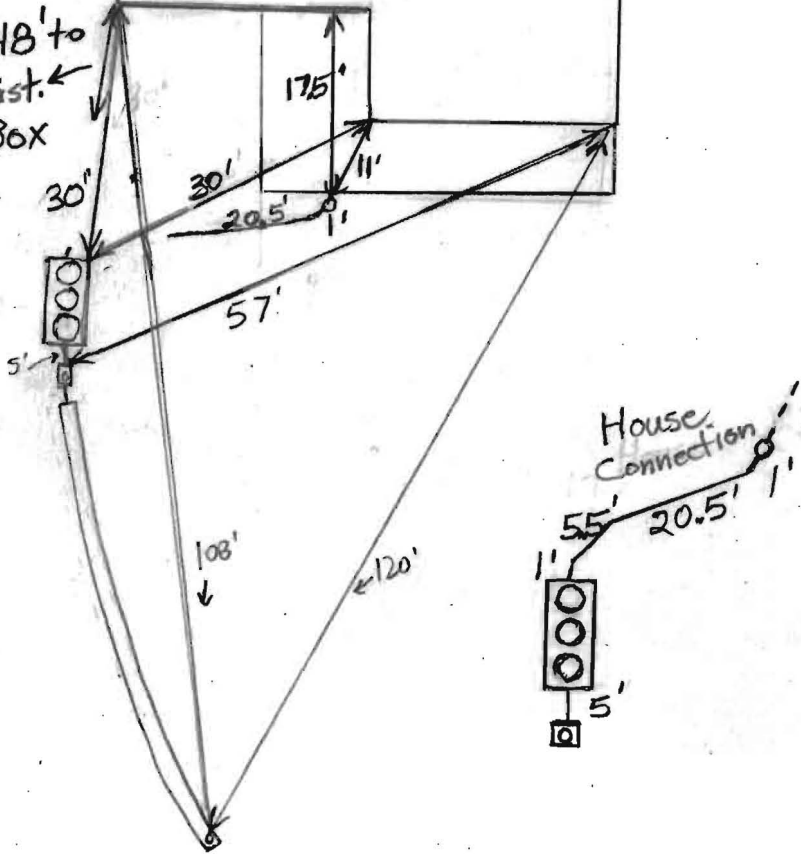

ROAD NAME

TRENCH/DRAINFIELD DATA

WIDTH	INLET	BOTTOM
2'		
NUMBER OF TRENCHES 1		
TOTAL LENGTH _____		
ABSORPTION AREA _____		
DISTRIBUTION BOX LEVEL N/A		
DISTRIBUTION BOX BAFFLE N/A		
DISTRIBUTION BOX PORT Yes		

SEPTIC TANK DATA

SEPTIC TANK I LEVEL	Yes
MANUFACTURER	Norweco
CAPACITY	INT 500 GAL
SEAM LOC	Top
TANK LID DEPTH	3'
BAFFLES	No
BAFFLE FILTER	Yes
MANHOLE LOC	FRONT, MID, + REAR
6" PORT LOC	None
WATERTIGHT TEST	N/A
SLOTTED	Yes
DATE ON LID	N/A

~~RUMP/SEPTIC TANK LEVEL N/A~~

MANUFACTURER	_____
CAPACITY	_____ GAL
SEAM LOC	_____
TANK LID DEPTH	_____
BAFFLES	_____
BAFFLE FILTER	_____
MANHOLE LOC	_____
6" PORT LOC	_____
WATERTIGHT TEST	_____
SLOTTED	_____
DATE ON LID	_____

PRE-CONSTRUCTION:

12/3/14 Layout given for tank and trench location

INSTALLATION:

4/17/15 Upon arrival on-site (late pm), BAT unit set. No other work completed. Ex. system still in use. (K) 4/21/15 D-box installed and connected to tank. Part of trench dug. Fogle's not on site. (C)

4/21/15 Trench finished and left open. 4' to stone, 2" wide. Existing tank still in use. Fogle's will pump + collapse tomorrow after connecting new tank to house. (C)

4/22/2015 Connection made from house to BAT unit. Need start-up certification from Norweco inspector. (BB)

4/27/2015 Received start-up certification from Norweco/

FINAL INSPECTOR

B. Baker

DATE OF APPROVAL

4/28/2015

Back River inspector. (BB) 4/28/2015 Start-up done with Fogle's. (BB)

Back River Pre-Cast, LLC

PO BOX 329
Glyndon, MD 21071
Phone # 410-833-3394
Fax # 410-833-4116

Letter of Certification

This is to certify that the Norweco Singlair TNT 600 GPD Septic Tank installed at 8549 Old Frederick Rd., Ellicott City, MD 21043 was installed on April 17, 2015 according to the manufacture's specifications.

Installer: Ricky Colson

Property Owner: Nicole Jensen



MATTHEW GECKLE

Vice-President

**AGREEMENT AND EASEMENT FOR INSTALLATION
OF BEST AVAILABLE TECHNOLOGY SYSTEMS
WITH BAY RESTORATION FUNDS.**

THIS AGREEMENT is made this 20th day of January 2015, among Nicole M. Jensen, hereinafter referred to as "Owner," the Howard County Health Department hereinafter collectively referred to as the "County," and the Department of the Environment, hereinafter referred to as the "Department."

WHEREAS, Owner owns a tract of land located on 8549 Old Frederick Rd. Ellicott City, MD 21043 in the 02 Election District of Howard County, Maryland, and the deed to same is recorded among the Land Records of Howard County, Maryland, in Columbia and in Liber 10200 Folio 00333

WHEREAS, the Bay Restoration Fund (BRF) may provide a grant for the cost attributable to upgrading an onsite sewage disposal system to the Best Available Technology (BAT) for the removal of nitrogen.

WHEREAS, the BRF may also provide a grant for the cost difference between a traditional onsite sewage disposal system and a system that utilizes the BAT for the removal of nitrogen.

WHEREAS, Owner understands that participation in the Bay Restoration Fund is voluntary.

NOW, THEREFORE, the parties hereto agree as follows:

- 20
40
55
- A. Owner hereby grants to the Department and the County the right to enter upon the property at any reasonable time for access to the system to make periodic inspections and the Owner agrees to provide any information and data requested and needed by the Department to develop accurate and thorough test results.
 - B. Owner acknowledges and agrees that a MDE certified and manufacturer-approved installer will install the BAT system.
 - C. Owner acknowledges and agrees the manufacturer or manufacturer's authorized service provider will provide for Operation and Maintenance of the BAT for a period of 5 years as a condition of sale of the BAT. After the initial 5 year period an Operation and Maintenance contract with a certified service provider must be maintained in perpetuity by the property owner.
 - D. Owner acknowledges and agrees that the manufacturer appointed Operation and Maintenance provider will have access to the BAT system at all times.
 - E. Owner acknowledges and agrees that the manufacturer or manufacturer's authorized service provider will have access to sample the effluent of the BAT system. Owner acknowledges and agrees that the proposed installation of a BAT system funded by the BRF is voluntary. Owner agrees that there shall be no liability on the part of the County or Department to Owner if this BAT system fails, and that the County and the Department do not warrant or guarantee that the BAT system will adequately or properly function.
 - F. Owner acknowledges and agrees that neither the County nor the Department nor any of its agents or employees, either officially or individually, underwrites the operation of any system approved by them.
 - G. The Owner will devote such care and effort to the maintenance of the BAT system so that any malfunction is not the result of poor maintenance, faulty operation, or neglect.

100% RECORDED

- H. The Canaan Valley Institute agrees to grant up to \$ _____ toward the cost of installation of the BAT system, and financial responsibility is limited to this amount. Operating costs will be at the Owners expense.
- I. The Owner acknowledges that the BRF grant can only be used for that portion of the OSDS attributable to (BAT) for the removal of nitrogen.
- J. Owner acknowledges in the event the total project cost is greater than \$25,000 the proposal will have to be approved by the Maryland State Board of Public Works.
- K. The Owner agrees to contact both the Water Management Administration, On-Site Systems Division of the Wastewater Permits Program and the County at least forty-eight (48) hours prior to system installation, so that the Department has the opportunity to be present at the time of installation or thereafter for inspection.
- L. The Owner must install BAT system according to the manufacturer recommended plans and specifications approved by the Department.
- M. The Owner agrees and acknowledges that if installation deviates substantially from the approved plans or changes such that performance of the system is compromised or reduced, BRF funding will not be provided.
- N. This agreement shall run with the land and binds the Owner, his heirs, successors, assigns. Owner further agrees that he shall inform in writing any purchaser or lessee of the property that the system may require maintenance or other attention. The Owner agrees to record this agreement in the land records of Howard County.
- O. This agreement shall not be construed to limit any authority of the Department to protect the public health, safety or comfort or to issue any other orders to take any other action that is now or may hereafter be within its authority.
- P. This agreement may be voided at the discretion of the Department if the system construction is not completed within six (6) months of the effective date of this agreement.
- Q. This agreement contains the entire agreement and understanding between the County and the Owner and the Department. There are no additional terms other than as contained in this agreement. This agreement may not be modified except in writing signed by each of the parties or by their authorized representatives.
- R. The laws of the State of Maryland govern the provisions of all transactions pursuant to this agreement.

IN WITNESS WHEREOF, the parties have signed and sealed this agreement on the date indicated above.

DATE: 1.20.15

Nicole M. Jensen
 Owner Nicole M. Jensen

DATE: 1/20/2015

Paul Nifon
 Howard County Health Department

LR - Agreement
 Recording Fee 20.00
 Grantor/Grantee Name:
 JENSEN
 Reference/Control #:
 121
 LR - Agreement
 Surcharge 40.00
 =====
 SubTotal: 60.00
 =====
 Total: 120.00
 01/20/2015 09:45
 CC13-ES
 #3748679 CC0503 -
 Howard Co
 Columbia/CC05.03.08 -

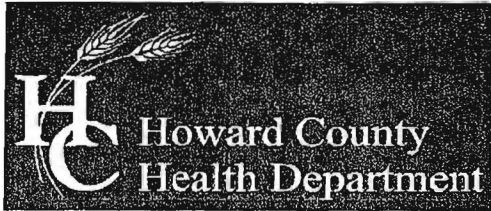

Bureau of Environmental Health

8930 Stanford Boulevard, Columbia, MD 21045

Main: 410-313-2640 | Fax: 410-313-2648

TDD 410-313-2323 | Toll Free 1-866-313-6300

www.hchealth.org

Facebook: www.facebook.com/hocohealth

Twitter: HowardCoHealthDep

Maura J. Rossman, M.D., Health Officer

**OPERATION AND MAINTENANCE AGREEMENT
FOR AN ON-SITE SEWAGE DISPOSAL SYSTEM
HAVING AN ADVANCED PRE-TREATMENT SYSTEM**

THIS AGREEMENT is made this 20th day of January, 2015, among Nicole M. Jensen, hereinafter collectively referred to as "Owner", and the Howard County Health Department hereinafter referred to as the "County".

WHEREAS, Owner is the owner or contract owner of a parcel of land located at 8549 Old Frederick Rd; Ellicott City, MD 21043, in the 02 Election District of Howard County, Maryland, and the deed to same is recorded or shall be recorded among the Land Records of Howard County, Maryland in Liber 10200 Folio 00333

WHEREAS, The Lot is suitable for the installation of a conventional on-site sewage disposal system with an advanced pre-treatment system, utilizing best available technology to perform nitrogen reduction, in accordance with the Code of Maryland Regulations 26.04.02.07, effective January 1, 2013. The pre-treatment device being installed is Norweco Singular TNT

NOW, THEREFORE, the parties hereto agree as follows:

A. Owner hereby grants to the County the right to enter upon the Lot at any reasonable time for access to the system to make periodic inspections and the Owner agrees to provide any information and data in Owner's possession reasonably requested and needed by the County to develop accurate and thorough test results.

B. Owner acknowledges and agrees that neither the County nor any of its agents or employees, either officially or individually, underwrites the operation of any system approved by them.

C. The Owner will devote reasonable care and effort to the operation and maintenance of the system in perpetuity or until a public sewer connection is made so that a system malfunction is not the result of poor maintenance, faulty operation, or neglect.

D. The Owner agrees to enter into a contract reasonably acceptable to the Owner and the County with a private entity to operate and maintain on a regularly scheduled basis an approved advanced pre-treatment system. The owner shall supply a copy of the contract to the County when it is renewed or altered.

E. This agreement shall run with the land and upon Owner's taking title to the Lot shall bind the Owner, their heirs, successors, and assigns to the provisions of the agreement as long as the property is in existence and after installation of the system. Owner further agrees that they shall

20
40
45

inform in writing any subsequent purchaser or lessee of the Lot that the system shall require maintenance or other attention. Upon taking title to the Lot, the Owner agrees to cause this agreement to be recorded in the Land Records of Howard County and assure that it becomes part of the Deed for the subject property in order that prospective buyers may be aware of the special conditions affecting this property.

F. This agreement shall not be construed to limit any authority of the County to protect the public health, safety or comfort or to issue any other orders to take any other action which is now or may hereafter be within its authority.

G. This agreement may be voided at any time at the discretion of the County.

H. This agreement contains the entire agreement and understanding between the County and the Owner. There are no additional terms other than as contained in this agreement. This agreement may not be modified, except in writing signed by each of the parties or by their authorized representatives.

I. The laws of the State of Maryland govern the provisions of all transactions pursuant to this agreement.

J. Owner acknowledges and agrees that interior renovations to increase the number of bedrooms or an increase in living space shall not be permitted without approval from the County.

IN WITNESS WHEREOF, the parties have signed and sealed this agreement on the date indicated above.

Nicole M. Jensen 1/20/15
Owner Nicole M. Jensen Date

Owner Date

Beet Nya 1/20/2015
Howard County Health Department

LR - Agreement
Recording Fee 20.00
Grantor/Grantee Name:
JENSEN
Reference/Control #:
122
LR - Agreement
Surcharge 40.00
SubTotal: 60.00
Total: 120.00
01/20/2015 09:45
CC13-ES
#3748670 CC0503 -
Howard Co
Columbia/CC05.03.08 -
Register 08

Wolf, Kevin

From: Williams, Jeffrey
Sent: Thursday, November 20, 2014 11:04 AM
To: Jensen, Nicole
Cc: Wolf, Kevin
Subject: RE: Bay Restoration Application

Sounds good. They will submit their application for a repair to us and we will schedule with them to do the work. We typically try to respond within a few days on repairs. The actual date scheduled may be a week or so further out depending on the contractor's availability. Thanks
Jeff

From: Jensen, Nicole [mailto:NMJENSE@carrollk12.org]
Sent: Thursday, November 20, 2014 9:10 AM
To: Williams, Jeffrey
Subject: RE: Bay Restoration Application

Hi Jeff!

Hope you're having a good week.

I just wanted to touch base with you to make sure there's nothing more I need to do at this time to keep moving forward with my septic system issues.

Last I heard from Fogle's they were applying for the permit for septic repair. They did come to my property to assess the land and they said that I would next hear back from them when they were ready to do the "perk" test.

I understand these things take time, so I'm not concerned, I just wanted to touch base to make sure the ball is still rolling in the right direction.

Thanks and have a great day!

Nicole Jensen

443.622.5306

Work: 410-751-3510

8549 Old Frederick Road

Ellicott City, MD 21043

From: Williams, Jeffrey [mailto:jewilliams@howardcountymd.gov]
Sent: Friday, October 17, 2014 1:32 PM
To: Jensen, Nicole
Subject: RE: Bay Restoration Application

Sorry I hadn't gotten back to you. I had emailed Utilities to confirm no public sewer, but I haven't heard back from them. To avoid further delays, I would suggest that you find a septic contractor to come to our office and apply for a septic repair. That will get the ball rolling and we can figure out the BAT unit in the process. I believe you have already done your BRF application with Kristin from Canaan Valley Institute, correct?

Jeff

From: Jensen, Nicole [mailto:NMJENSE@carrollk12.org]
Sent: Friday, October 17, 2014 9:41 AM
To: Williams, Jeffrey
Subject: RE: Bay Restoration Application

Thank you so much for this info, Jeff. Again, I really appreciate your help because this seems so incredibly overwhelming and confusing to me!

I just wanted to touch base with you to see if you had found out any additional information or if there is anything I should be doing at this point. Every time I run water in my home (laundry, showers, dishes, etc.) the backyard floods, so I have the constant reminder that something needs to be done before too long so I at least want to make sure I'm taking steps in the right direction!

Thanks again and I hope you have a nice weekend!

Nicole
Nicole Jensen
8549 Old Frederick Road
Ellicott City, MD 21043
443.622.5306

From: Williams, Jeffrey [mailto:jewilliams@howardcountymd.gov]
Sent: Friday, October 10, 2014 8:46 AM
To: Jensen, Nicole
Subject: RE: Bay Restoration Application

Let me confirm with utilities that you do not have the ability to connect to public sewer. If they confirm that you cannot, the next step will be for you to hire a septic contractor to apply for a repair permit with our office. One of our Sanitarians will schedule with the contractor to find a suitable area in the yard for septic and oversee installation.

Assuming that this is the way things go, you may apply for BRF money to install a Best Available Technology (BAT) unit instead of a traditional septic tank, though it is not required. If you have a cesspool, you will need to install some sort of tank. A traditional septic tank is a concrete tank under the ground where the sewage goes from the house. The liquid leaves there to go to a subsurface drainfield to drain into the soil. A traditional tank flows by gravity and allows the solids to settle out and provides some organic treatment to break down solids and biologic components.

A BAT unit replaces the traditional tank and is essentially the same thing except it has an extra chamber with an electrically powered aerobic process that reduces nitrogen in the wastewater. On a repair, you are not required to install a BAT unit, though it is required on new construction and expansions. The BRF can typically pay for the initial cost of the BAT unit (roughly \$12,000). However, we are on a waiting list right now with funding. We anticipate getting some additional money in December.

Let me see what utilities says and I will get back to you. Thanks
Jeff

From: Jensen, Nicole [mailto:NMJENSE@carrollk12.org]
Sent: Thursday, October 09, 2014 3:58 PM
To: Williams, Jeffrey
Subject: RE: Bay Restoration Application

Thanks for getting back to me, Jeff!

I'm sorry to sound so clueless but I could really use any help you can offer. My house was built in 1947 and Fogle's Septic company has told me that it's a cess pool, not technically a septic system and that it has definitely failed because it floods over into the yard every time we run any household water. They also told me that people on my side of Old Frederick Road couldn't tap into the county sewer and that we had to stay septic but I'm not sure how valid that information is. I'll contact whoever I need to contact if there's more information that I need to provide but I honestly don't know who to call or what to say exactly so I do very much appreciate your help. So what next?

Thanks again!
Nicole Jensen
8549 Old Frederick Road
Ellicott City, MD 21043
443.622.5306

From: Williams, Jeffrey [mailto:jewilliams@howardcountymd.gov]
Sent: Thursday, October 09, 2014 10:49 AM
To: Jensen, Nicole
Subject: RE: Bay Restoration Application

Hello Nichole. Sorry for the phone tag. Have you determined from the county Bureau of Utilities whether you have access to the public sewer? It looks on the county map available to me that it just misses your section of the street. If you don't have access, you could repair your septic system and based on why it is failing, you could install a BAT unit with BRF grant money. However, in an onsite repair, you are not required to install a BAT and if the existing tank is ok, you might not need to replace the tank at all.

If you do have the ability to connect to the public sewer, the BRF could help pay for that connection. Can we start with some information on how the system is failing and if you know if public sewer is available? If you don't know I can look into it with Utilities. Thanks

Jeff Williams
Program Supervisor, Well & Septic Program
Bureau of Environmental Health
Howard County Health Dept.
410-313-4261
jewilliams@howardcountymd.gov

CONFIDENTIALITY NOTICE

This message and the accompanying documents are intended only for the use of the individual or entity to which they are addressed and may contain information that is privileged, confidential, or exempt from disclosure under applicable law. If the reader of this email is not the intended recipient, you are hereby notified that you are strictly prohibited from reading, disseminating, distributing, or copying this communication. If you have received this email in error, please notify the sender immediately and destroy the original transmission.

From: Jensen, Nicole [mailto:NMJENSE@carrollk12.org]
Sent: Friday, September 26, 2014 1:22 PM
To: kristin.mielcarek@canaanvi.org; Williams, Jeffrey
Subject: Bay Restoration Application

Thank you for the information. I am attaching the application.

Nicole Jensen
8549 Old Frederick Road
Ellicott City, MD 21043
443.622.5306
njensen971@gmail.com