

U.S. EQUIVALENT COORDINATE TABLE			METRIC EQUIVALENT COORDINATE TABLE		
POINT	NORTH	EAST	POINT	NORTH	EAST
40	595422.199500	1294532.868500	40	181485.049378	394574.407468
41	595270.126500	1294594.782100	41	181438.697435	394593.278771
183	595540.397720	1294440.493789	183	181521.074134	394546.251599
184	595660.029505	1294449.797616	184	181557.540108	394549.087412
205	595622.044582	1294928.352785	205	181546.196977	394694.951319
220	594932.285401	1295043.381760	220	181335.723262	394730.012220

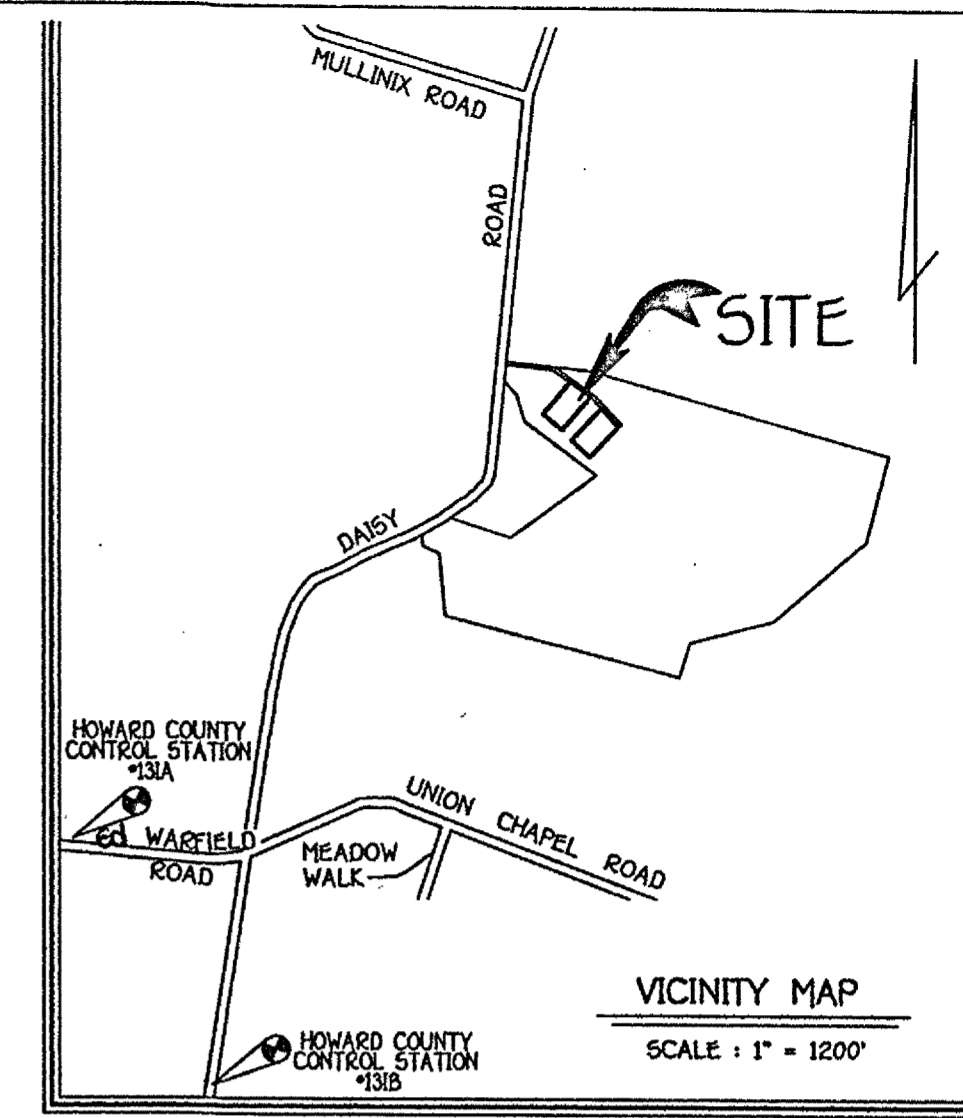
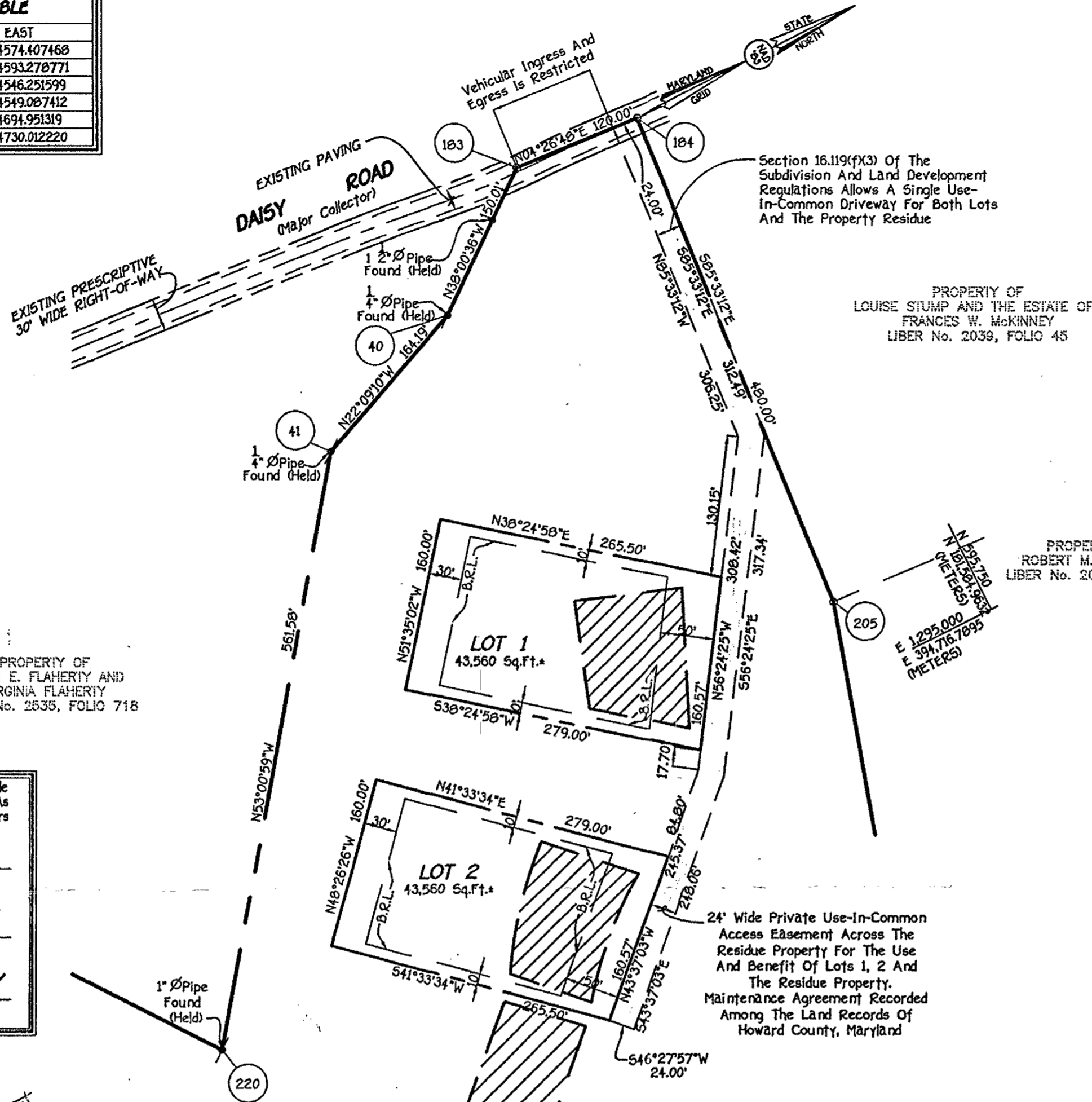

E 1294.500  
E 394,568.3697  
(METERS)  
N 595,720  
N 1294,928  
(METERS)

PROPERTY OF  
HUGH E. FLAHERTY AND  
VIRGINIA FLAHERTY  
LIBER No. 2535, FOLIO 718

PROPERTY OF  
ROBERT M. WARFIELD  
LIBER No. 2039, FOLIO 45

**GENERAL NOTES:**

- This Area Designates A Private Sewerage Easement Of 10,000 Square Feet As Required By The Maryland State Department Of The Environment For Individual Sewage Disposal. Improvements Of Any Nature In This Area Are Restricted Until Public Sewerage Is Available. These Easements Shall Become Null And Void Upon Connection To A Public Sewerage System. The County Health Officer Shall Have The Authority To Grant Variances For Encroachments Into The Private Sewerage Easement. Recordation Of A Modified Easement Shall Not Be Necessary.
- Subject Property Zoned RC-DEO Per 10/18/93 Comprehensive Zoning Plan.
- Coordinates Based On Nad '83, Maryland Coordinate System As Projected By Howard County Geodetic Control Stations No. 131A And No. 131B.  
Sta. 131A N 180654.5053 m E 393726.7507 m  
Sta. 131B N 180183.6976 m E 393986.0560 m
- This Plat Is Based On Field Run Monumented Boundary Survey Performed On Or About June, 1995, By Fisher, Collins And Carter, Inc.
- B.R.L. Denotes Building Restriction Line.
- Denotes Iron Pin Set Capped "F.C.C. 106".
- Denotes Iron Pipe Or Iron Bar Found.
- Denotes Angular Change In Bearing Of Boundary Or Rights-Of-Way.
- Denotes Concrete Monument Set With Aluminum Plate "F.C.C. 106".
- Denotes Concrete Monument Or Stone Found.
- Refuse Collection, Snow Removal And Road Maintenance To Be Provided At The Junction Of Use-In-Common Access Easement And The Road R/W And Not Onto The Use-In-Common Driveway.
- Driveway(s) Shall Be Provided Prior To Residential Occupancy To Insure Safe Access For Fire And Emergency Vehicles Per The Following (Minimum) Requirements:  
a) Width - 12 Feet (4 Feet Serving More Than One Residence;  
b) Surface - Six (6") Inches Of Compacted Crusher Run Base With Tar And Chip Coating. (1 - 1/2" Minimum);  
c) Geometry - Maximum 15% Grade, Maximum 10% Grade Change And 45-Foot Turning Radius;  
d) Structures (Culverts/Bridges) - Capable Of Supporting 25 Gross Tons (H25-Loading);  
e) Drainage Elements - Capable Of Safely Passing 100 Year Flood With No More Than 1 Foot Depth Over Surface;  
f) Structure Clearances - Minimum 12 Feet;  
g) Maintenance - Sufficient To Insure All Weather Use. No Clearing, Grading Or Construction Is Permitted Within Wetland Or Stream Buffers. Unless, Approved By The Department Of Planning And Zoning Of Howard County, Maryland.
- All Lot Areas Are More Or Less (±).
- Distances Shown Are Based On Surface Measurement And Not Reduced To Nad '83 Measurement.
- Lots 1 And 2 Are Created In Accordance With Section 104.E.6. Of The Zoning Regulations.
- This Plat Is Subject To Section 15.514(b) Of The Agricultural Preservation Program.
- This Subdivision Is Exempt From The Requirements Of The Forest Conservation Program Per Section 16.1202(b)(vii) Of The Subdivision And Land Development Regulations. Landscaping Requirements For These Lots Are In Accordance With The Alternative Compliance Provisions Of Section 16.124 Of The Howard County Code And The Landscape Manual As A Result Of The Lot's Site Location Within The Farm's Interior And Surrounding Existing Woods.
- Lots Shown On This Plat Comply With Minimum Ownership Width And Lot Areas As Required By The Maryland State Department Health Regulations.
- There Are No Non-Tidal Wetlands Existing Within The Limits Of Proposed Lots 1 And 2.

The Requirements §3-108, The Real Property Article, Annotated Code Of Maryland, 1988 Replacement Volume, As Supplemented As Far As They Relate To The Making Of This Plat And The Setting Of Markers Have Been Complied With

*Terrell A. Fisher* 10/6/98  
Terrell A. Fisher, L.S. #10692  
(Registered Land Surveyor) Date

*James L. Phelps* 10/5/98  
James L. Phelps  
(Witness) Date

*Corá S. Phelps* 10/5/98  
Corá S. Phelps  
(Owner) Date

E 1295.000  
E 394,716.7899  
(METERS)  
N 594,720  
N 1295,000  
(METERS)

RESIDUE  
PROPERTY OF  
JAMES L. PHELPS AND  
CORÁ S. PHELPS  
LIBER No. 4443, FOLIO 356  
(MAP: 8, PARCEL: 7 OF THE  
HOWARD COUNTY LAND PRESERVATION  
EASEMENT #H096-02E)

**OWNER**  
Mr. James L. Phelps and  
Mrs. Corá S. Phelps  
P.O. Box 2050  
3440 Ellicott Center Drive  
Ellicott City, Maryland 21041-0014

**DEVELOPER**  
Mr. Jim Phelps  
c/o Regional Underwriters Service Company  
P.O. Box 2050  
3440 Ellicott Center Drive  
Ellicott City, Maryland 21041-0014

**FISHER, COLLINS & CARTER, INC.**  
CIVIL ENGINEERING CONSULTANTS & LAND SURVEYORS  
CENTENNIAL SQUARE OFFICE PARK - 10272 BALTIMORE NATIONAL PIKE  
ELICOTT CITY, MARYLAND 21042  
(410) 461 - 2255

**TOTAL SHEET AREA TABULATION**

Total Number Of Buildable Lots To Be Recorded	2
Total Number Of Open Space Lots To Be Recorded	0
Total Number Of Lots To Be Recorded	2
Total Area Of Buildable Lots To Be Recorded	2.000 AC.
Total Area Of Open Space Lots To Be Recorded	0.000 AC.
Total Area Of Lots To Be Recorded	2.000 AC.
Total Area Of Roadway To Be Recorded	0.000 AC.
Total Area To Be Recorded	2.000 AC.

Approved: For Private Water And Private Sewerage Systems, Howard County Health Department.

*Joyce M. Boyd* 10/6/98  
Howard County Health Officer Date

Approved: Howard County Department Of Planning And Zoning.

*James S. Butler* 10/23/98  
Chief, Development Engineering Division Date

*James S. Butler* 10/29/98  
Director Date

**OWNER'S CERTIFICATE**

James L. Phelps And Corá S. Phelps, Husband And Wife, Owners Of The Property Shown And Described Hereon, Hereby Adopt This Plan Of Subdivision, And In Consideration Of The Approval Of This Final Plat By The Department Of Planning And Zoning, Establish The Minimum Building Restriction Lines And Grant Unto Howard County, Maryland, Its Successors And Assigns: (1) The Right To Lay, Construct And Maintain Sewers, Drains, Water Pipes And Other Municipal Utilities And Services In And Under All Roads And Street Rights-Of-Way And The Specific Easement Areas Shown Hereon; (2) The Right To Require Dedication For Public Use The Beds Of The Streets And/OR Roads And Floodplains And Open Space Where Applicable And For Good And Other Valuable Consideration, Hereby Grant The Right And Option To Howard County To Acquire The Fee Simple Title To The Beds Of The Streets And/OR Roads And Floodplains, Storm Drainage Facilities And Open Space Where Applicable; (3) The Right To Require Dedication Of Waterways And Drainage Easements For The Specific Purpose Of Their Construction, Repair And Maintenance; And (4) That No Building Or Similar Structure Of Any Kind Shall Be Erected On Or Over The Said Easements And Rights-Of-Way. Witness My Hand This 5<sup>th</sup> Day Of October, 1998.

*James L. Phelps*  
James L. Phelps  
Corá S. Phelps  
Corá S. Phelps

*James L. Phelps*  
Witness  
*James L. Phelps*  
Witness

**SURVEYOR'S CERTIFICATE**

I Hereby Certify That The Final Plat Shown Hereon Is Correct; That It Is A Subdivision Of Part Of The Lands Conveyed By Louise W. Stump; John C. Poulton, Personal Representative Of The Estate Of Robert M. Warfield, Deceased, Late Of Howard County, Maryland; And Laura McLane McKinney, Executrix Of The Estate Of Frances W. McKinney, Deceased, Late Of Fayette County, Kentucky To James L. Phelps And Corá S. Phelps By Deed Dated September 22, 1998 And Recorded In The Land Records Of Howard County, Maryland In Liber No. 4443 At Folio 356, And That All Monuments Are In Place Or Will Be In Place Prior To Acceptance Of The Streets In The Subdivision By Howard County, Maryland As Shown, In Accordance With The Annotated Code Of Maryland, As Amended, And Monumentation Is In Accordance With The Howard County Subdivision Regulations.

*Terrell A. Fisher* 10/6/98  
Terrell A. Fisher, Professional Land Surveyor No. 10692 Date

Recorded As Plat No. 13390 On 10/4/98  
Among The Land Records Of Howard County, Maryland.

**ROBERT WARFIELD PROPERTY**

LOTS 1 AND 2  
ZONED: RC-DEO

TAX MAP No. 14 GRID #7 PART OF PARCEL No. 7  
FOURTH ELECTION DISTRICT  
HOWARD COUNTY, MARYLAND

0' 100' 150' 200'  
Scale: 1" = 100'

DATE: OCTOBER 1, 1998  
SHEET 1 OF 1  
F99-06

F-99-06

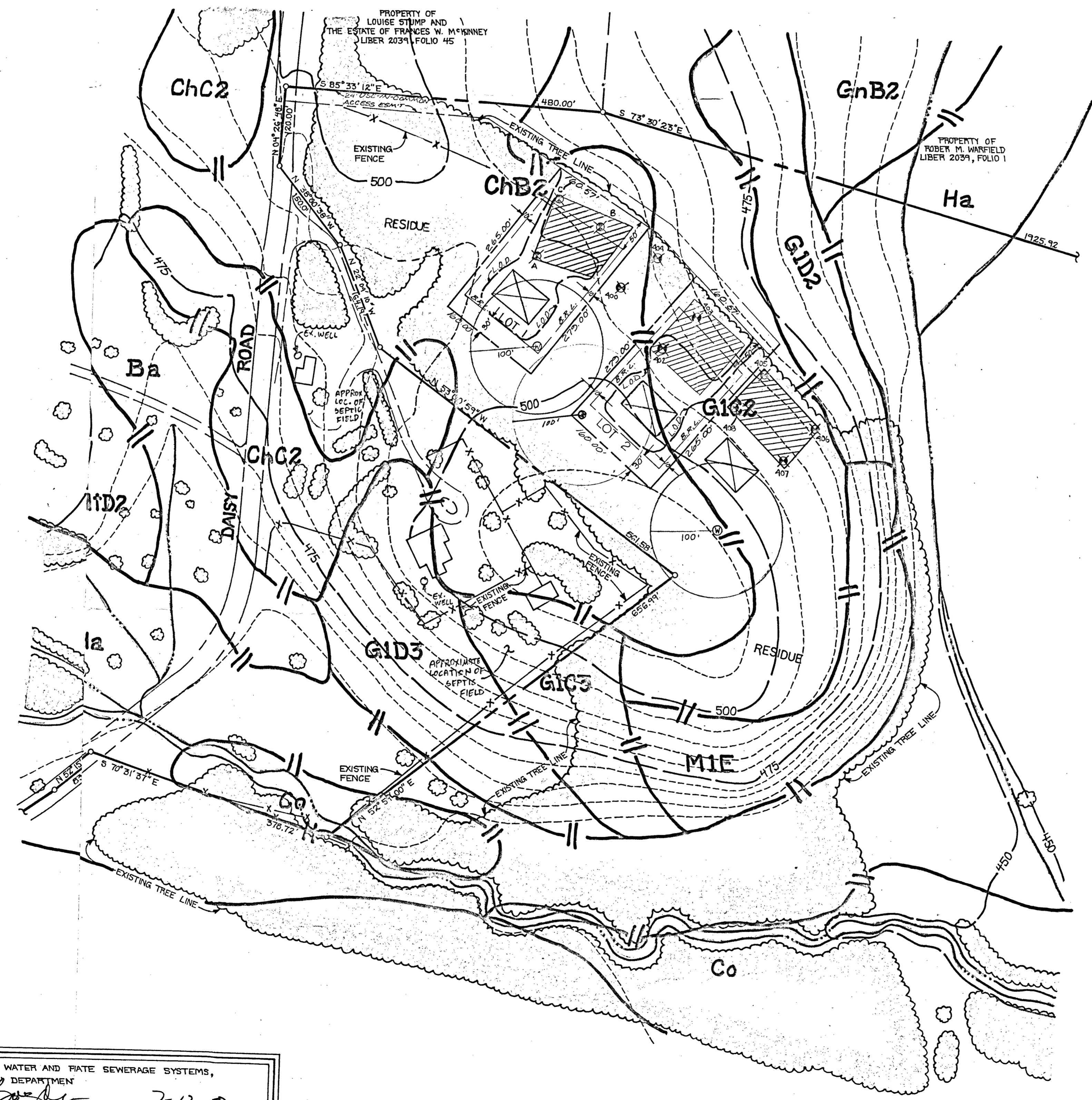
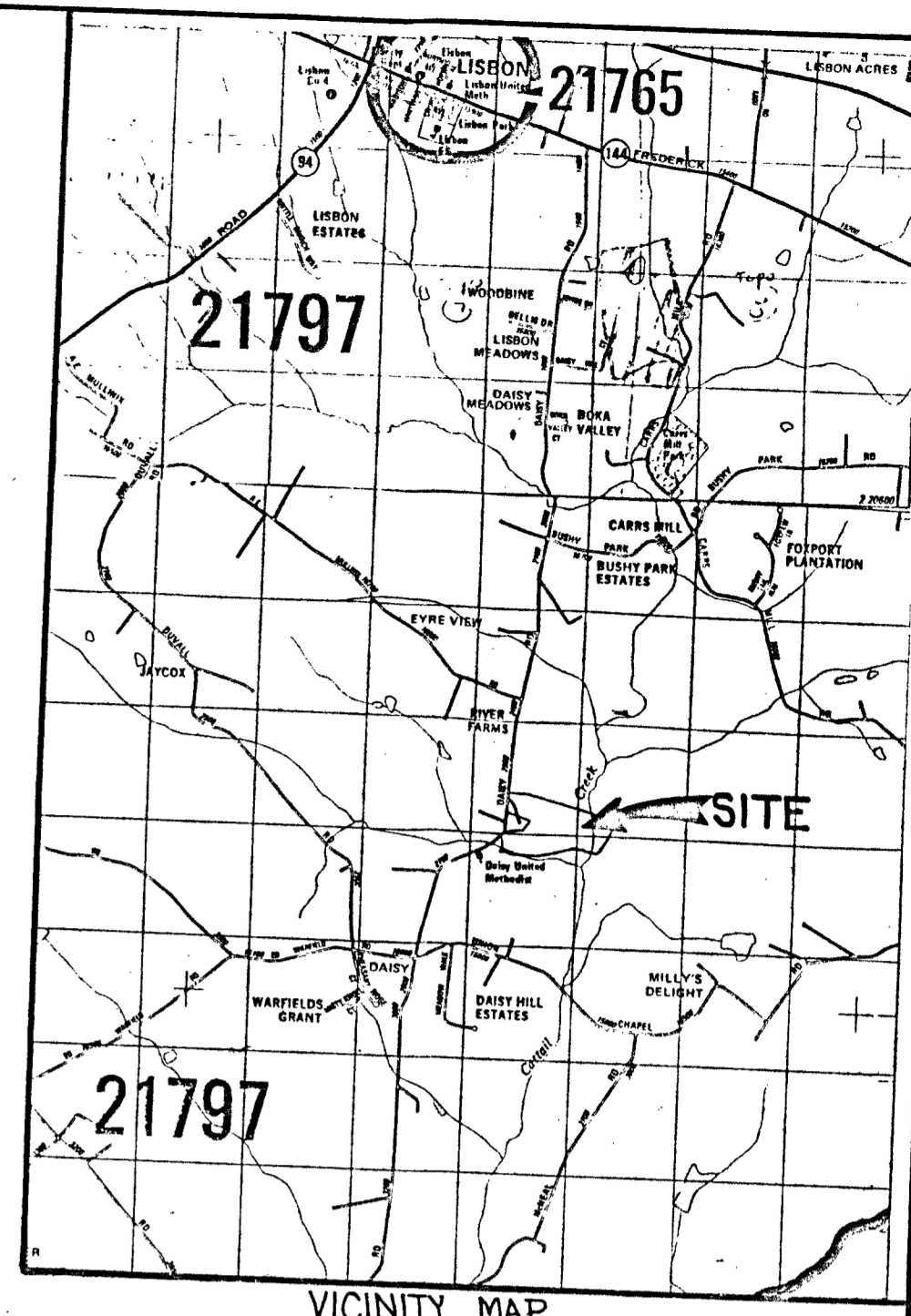

**GENERAL NOTES:**

1. [Hatched symbol] THIS AREA DESIGNATES A PRIVATE SEWERAGE EASEMENT OF 10,000 SQUARE FEET AS REQUIRED BY THE MARYLAND STATE DEPARTMENT OF THE ENVIRONMENT FOR INDIVIDUAL SEWERAGE DISPOSAL IMPROVEMENTS OF ANY NATURE IN THIS AREA ARE RESTRICTED UNTIL PUBLIC SEWERAGE IS AVAILABLE. THESE EASEMENTS SHALL BECOME NULL AND VOID UPON CONNECTION TO A PUBLIC SEWERAGE SYSTEM. THE COUNTY HEALTH OFFICER SHALL HAVE THE AUTHORITY TO GRANT VARIANCES OF ENCROACHMENT INTO THE PRIVATE SEWERAGE EASEMENT. RECORDATION OF A MODIFIED SEWERAGE EASEMENT SHALL NOT BE NECESSARY.
2. THE LOT SHOWN HEREON COMPLY WITH THE MINIMUM OWNERSHIP WIDTH AND LOT AREA AS REQUIRED BY THE MARYLAND STATE DEPARTMENT OF THE ENVIRONMENT.
3. ALL WELLS AND SEPTIC SYSTEM WITHIN 100 FEET OF THE PROPERTY HAVE BEEN SHOWN.
4. (W) DENOTES WELL LOCATION.
5. (P) DENOTES PERC HOLE LOCATION.
6. TOTAL NO. OF PROPOSED BUILDABLE LOTS = 2
7. TOTAL AREA OF PROPOSED BUILDABLE LOTS = 2.0 AC.

**LANDSCAPING REQUIREMENTS**  
 LOTS 1 AND 2 ARE 100% WOODED LOTS.  
 THEREFORE, 100% CREDIT IS REQUESTED ALONG THE FOUR LOT LINES OF EACH OF LOTS 1 AND 2.

**FISHER, COLLINS & CARTER, INC.**  
 CIVIL ENGINEERING CONSULTANTS &  
 LAND SURVEYORS  
 CENTENNIAL SQUARE OFFICE PARK  
 10272 BALTIMORE NATIONAL PIKE  
 ELLICOTT CITY, MARYLAND 21042  
 410-461-2855

APPROVED FOR PRIVATE WATER AND SEWERAGE SYSTEMS,  
 HOWARD COUNTY HEALTH DEPARTMENT  
*[Signature]*  
 COUNTY HEALTH OFFICER  
 DATE: 7-13-78

*[Signature]*  
 E. G. C. S.

**PERCOLATION TEST CERTIFICATION**  
**TOPOGRAPHIC AND SOILS PLAN**  
**ROBERT WARFIELD PROPERTY**  
 LOTS 1 AND 2  
 TAX MAP 14 PART OF PARCEL 7 GRID 7  
 FOURTH ELECTION DISTRICT  
 HOWARD COUNTY, MARYLAND  
 JULY, 1978  
 SCALE: 1"=100'

DAISY ROAD



594500  
1294750

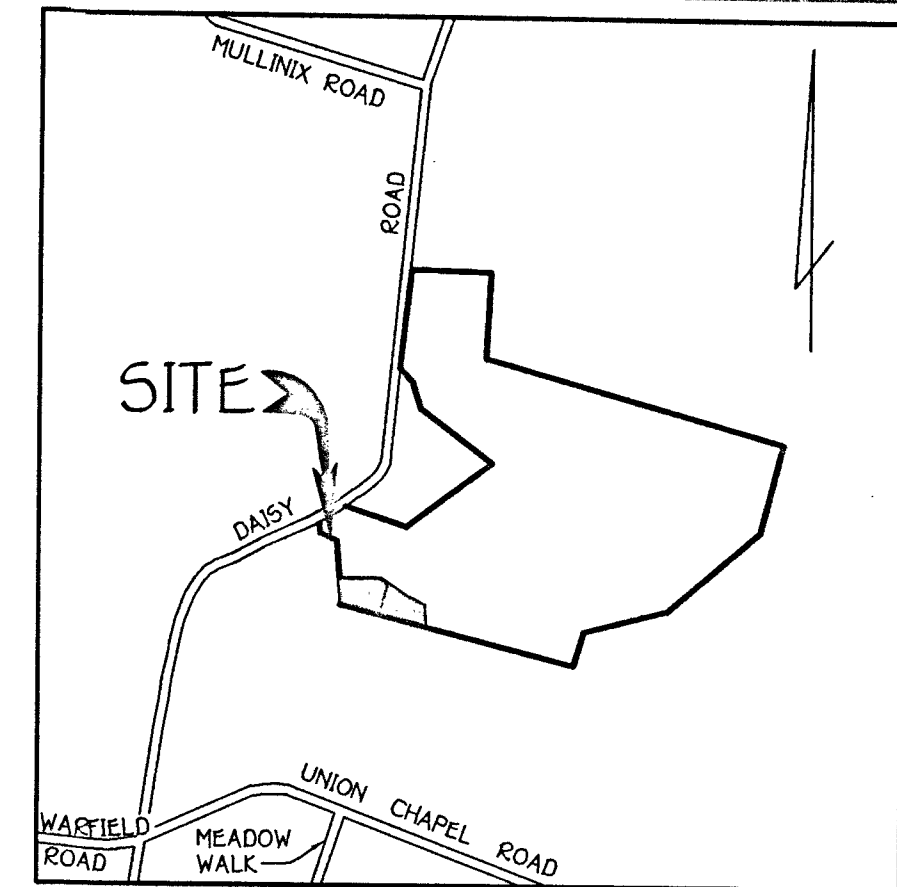

VICINITY MAP  
SCALE: 1" = 1200'

PROPERTY OF M. WARFIELD, LOUISE W. STUMP AND THE ESTATES OF FRANKS W. MCKINNEY  
LIBER 2039, FOLIO 34

PROPERTY OF TRUSTEES OF DAISY METHODIST CHURCH  
LIBER 771, FOLIO 427

LOT 1  
59,640 Sq.Ft.±

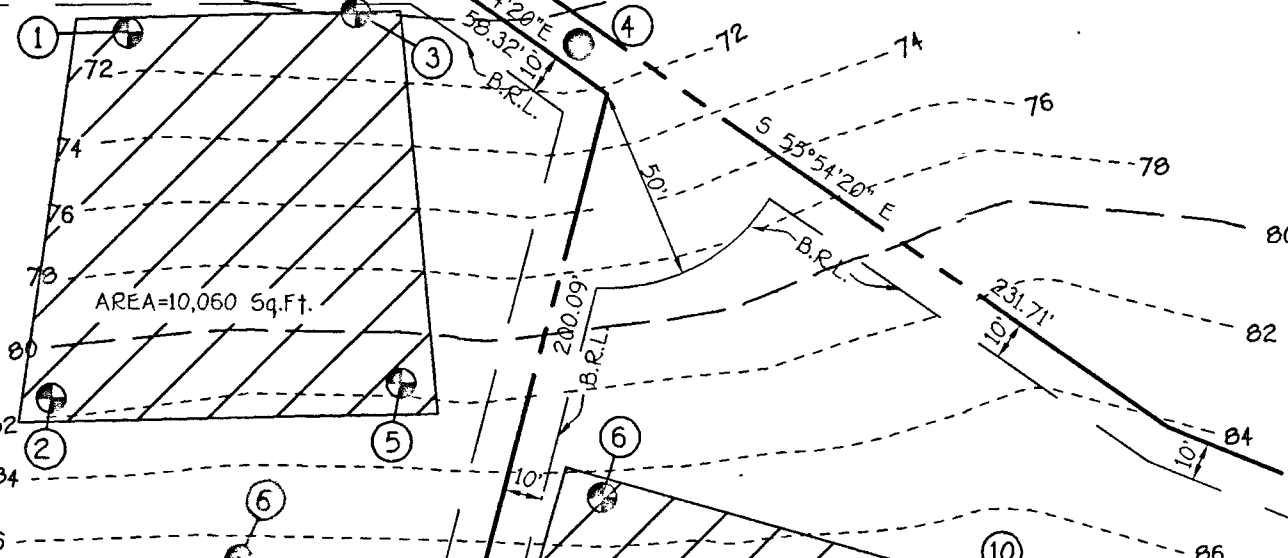

LOT 2  
46,970 Sq.Ft.±

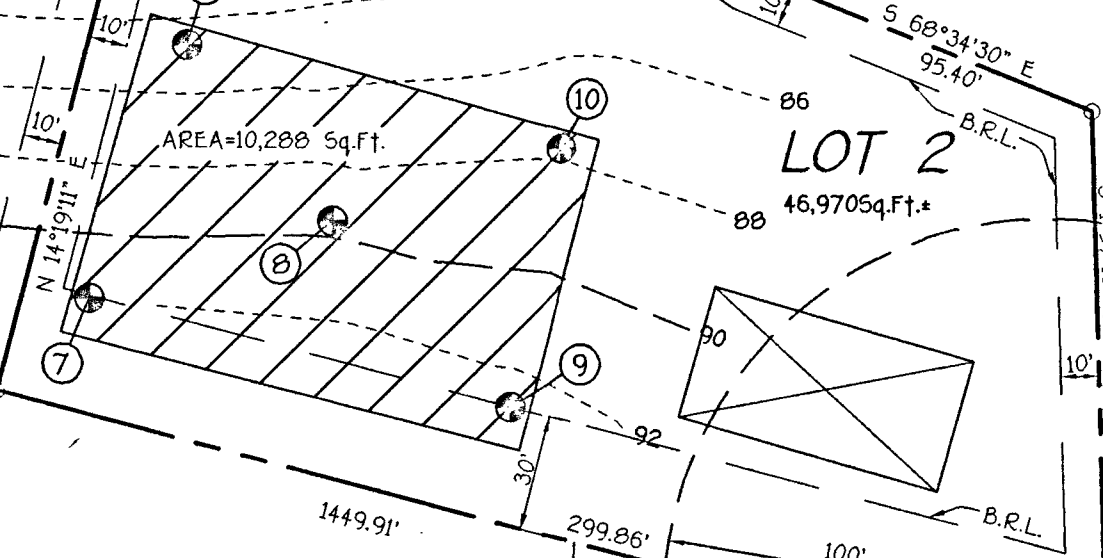

GENERAL NOTES:

1. THIS AREA DESIGNATES A PRIVATE SEWERAGE EASEMENT OF 10,000 SQUARE FEET AS REQUIRED BY THE MARYLAND STATE DEPARTMENT OF THE ENVIRONMENT FOR INDIVIDUAL SEWERAGE DISPOSAL. IMPROVEMENTS OF ANY NATURE IN THIS AREA ARE RESTRICTED UNTIL PUBLIC SEWERAGE IS AVAILABLE. THESE EASEMENTS SHALL BECOME NULL AND VOID UPON CONNECTION TO A PUBLIC SEWERAGE SYSTEM. THE COUNTY HEALTH OFFICER SHALL HAVE THE AUTHORITY TO GRANT VARIANCES FOR ENCROACHMENT INTO THE PRIVATE SEWERAGE EASEMENT. RECORDATION OF A MODIFIED SEWERAGE EASEMENT SHALL NOT BE NECESSARY.
2. THE LOT SHOWN HEREON COMPLY WITH THE MINIMUM OWNERSHIP WIDTH AND LOT AREA AS REQUIRED BY THE MARYLAND STATE DEPARTMENT OF THE ENVIRONMENT.
3. ALL WELLS AND SEPTIC SYSTEM WITHIN 100 FEET OF THE PROPERTY HAVE BEEN SHOWN.
4. (W) DENOTES WELL LOCATION.
5. (P) DENOTES PERC HOLE LOCATION.
6. (F) DENOTES FAILED PERC HOLE LOCATION.
7. (10) DENOTES HEALTH DEPARTMENT PERCOLATION NUMBERING SYSTEM.
8. OWNER & DEVELOPER:

ESTATE OF ROBERT WARFIELD  
C/O MR. JOHN POULTON  
OBER, KALER, GRIMES, AND SHRIVER  
120 E. BALTIMORE STREET  
BALTIMORE, MARYLAND 21202

9. ALL WELLS TO BE DRILLED PRIOR TO RECORD PLAT SUBMITTAL FOR SIGNATURE BY HOWARD COUNTY HEALTH DEPARTMENT.

*Stirling B. Russell*

PERC CERTIFICATION PLAT  
ROBERT WARFIELD PROPERTY  
LOTS 1 AND 2

APPROVED FOR PRIVATE WATER AND PRIVATE SEWERAGE SYSTEMS,  
HOWARD COUNTY HEALTH DEPARTMENT.  
*Stirling B. Russell*  
COUNTY HEALTH OFFICER (LH) DATE 2-6-98

PROPERTY OF JOSEPH J. JUNGGOUST, ETAL.  
LIBER 580, FOLIO 600

TAX MAP 14 ZONED: RC-DEO PARCEL(S): P/O 7  
FOURTH ELECTION DISTRICT HOWARD COUNTY, MARYLAND  
SCALE: 1"=50' DATE: JANUARY 12, 1998  
REVISED: JANUARY 29, 1998

FISHER, COLLINS & CARTER, INC.  
CIVIL ENGINEERING CONSULTANTS & LAND SURVEYORS  
CENTRAL SQUARE OFFICE PARK - 10272 BALTIMORE NATIONAL PIKE  
ELLCOTT CITY, MARYLAND 21042  
(410) 461 - 2895

DAISY ROAD

R=542.30' L=12.86'  
R=542.30' L=12.98'



594500  
1294750

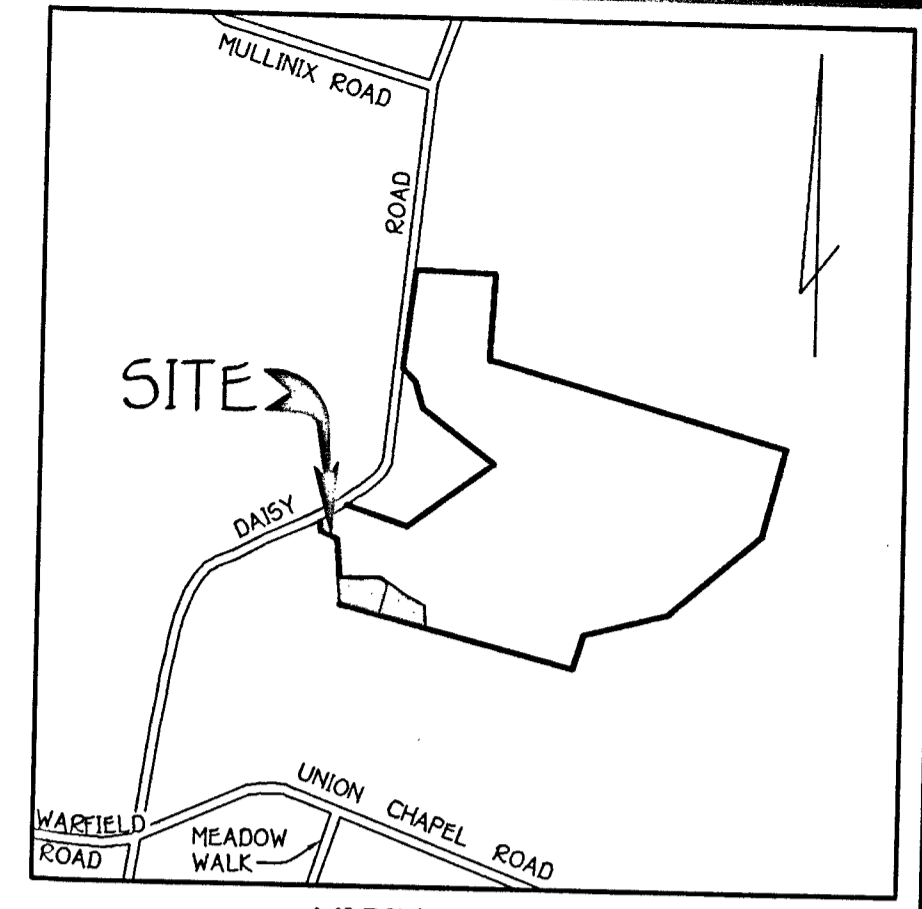

VICINITY MAP  
SCALE: 1" = 1200'

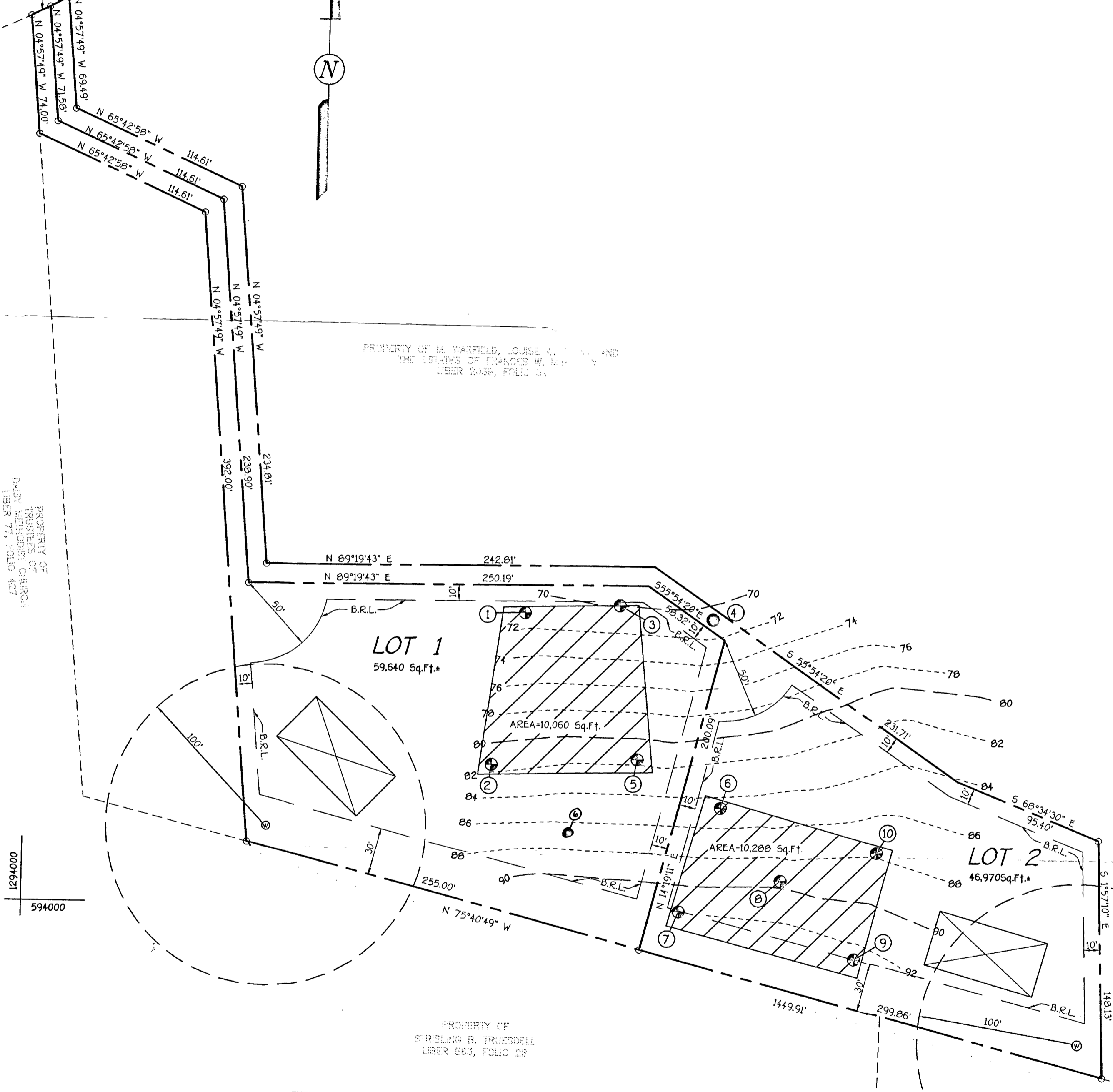

GENERAL NOTES:

1. THIS AREA DESIGNATES A PRIVATE SEWERAGE EASEMENT OF 10,000 SQUARE FEET AS REQUIRED BY THE MARYLAND STATE DEPARTMENT OF THE ENVIRONMENT FOR INDIVIDUAL SEWERAGE DISPOSAL. IMPROVEMENTS OF ANY NATURE IN THIS AREA ARE RESTRICTED UNTIL PUBLIC SEWERAGE IS AVAILABLE. THESE EASEMENTS SHALL BECOME NULL AND VOID UPON CONNECTION TO A PUBLIC SEWERAGE SYSTEM. THE COUNTY HEALTH OFFICER SHALL HAVE THE AUTHORITY TO GRANT VARIANCES FOR ENCROACHMENT INTO THE PRIVATE SEWERAGE EASEMENT. RECORDATION OF A MODIFIED SEWERAGE EASEMENT SHALL NOT BE NECESSARY.
2. THE LOT SHOWN HEREON COMPLY WITH THE MINIMUM OWNERSHIP WIDTH AND LOT AREA AS REQUIRED BY THE MARYLAND STATE DEPARTMENT OF THE ENVIRONMENT.
3. ALL WELLS AND SEPTIC SYSTEM WITHIN 100 FEET OF THE PROPERTY HAVE BEEN SHOWN.
4. (W) DENOTES WELL LOCATION.
5. (P) DENOTES PERC HOLE LOCATION.
6. (F) DENOTES FAILED PERC HOLE LOCATION.
7. (10) DENOTES HEALTH DEPARTMENT PERCOLATION NUMBERING SYSTEM.
8. OWNER & DEVELOPER:

ESTATE OF ROBERT WARFIELD  
C/O MR. JOHN POULTON  
OBER, KALER, GRIMES, AND SHRIVER  
120 E. BALTIMORE STREET  
BALTIMORE, MARYLAND 21202

9. ALL WELLS TO BE DRILLED PRIOR TO RECORD PLAT SUBMITTAL FOR SIGNATURE BY HOWARD COUNTY DEPARTMENT OF PLANNING AND ZONING. HEALTH DEPARTMENT.



PERC CERTIFICATION PLAT  
ROBERT WARFIELD PROPERTY  
LOTS 1 AND 2

TAX MAP 14 ZONED: RC-DEO PARCEL(S): P/O 7  
FOURTH ELECTION DISTRICT HOWARD COUNTY, MARYLAND  
SCALE: 1"=50' DATE: JANUARY 12, 1998  
REVISED: JANUARY 29, 1998

APPROVED FOR PRIVATE WATER AND PRIVATE SEWERAGE SYSTEMS,  
HOWARD COUNTY HEALTH DEPARTMENT.  
*Joseph M. Jones*  
COUNTY HEALTH OFFICER (10)  
DATE 2-6-98

FISHER, COLLINS & CARTER, INC.  
CIVIL ENGINEERING CONSULTANTS & LAND SURVEYORS  
CENTENNIAL SQUARE OFFICE PARK - 10272 BALTIMORE NATIONAL PKE.  
ELLICOTT CITY, MARYLAND 21042  
(410) 461-2055