

INSP 1

~~INSP 1~~ 4/21/09 INSP 4 _____

INSP 2 4/29/09 INSP 5 _____

INSP 3 4/30/09 INSP 6 _____

ISSUE DATE: 4/30/2009

PERMIT

*(logged into
put firm)*

P 530982

APPROVAL DATE: 4/30/09

A BRF

Tax ID # 04-328566

ON-SITE SEWAGE DISPOSAL SYSTEM HOWARD COUNTY HEALTH DEPARTMENT BUREAU OF ENVIRONMENTAL HEALTH

Chief Septic _____ IS PERMITTED TO INSTALL ALTER

ADDRESS: PO Box 119 Mt. Airy MD PHONE NUMBER: 410-635-3237

SUBDIVISION: _____ LOT NUMBER: _____

ADDRESS: 16058 Ed Warfield Rd. PROPERTY OWNER: Tim McIntosh

SEPTIC TANK CAPACITY (GALLONS): 1500 OUTLET BAFFLE FILTER REQUIRED

PUMP CHAMBER CAPACITY (GALLONS): N/A COMPARTMENTED TANK REQUIRED

NUMBER OF BEDROOMS: _____

SQUARE FEET PER BEDROOM: _____

LINEAR FEET OF TRENCH REQUIRED: _____

TRENCHES:	Trench to be _____ feet wide. Inlet _____ feet below original grade. Bottom maximum depth _____ feet below original grade. Effective area begins at _____ feet below original grade. _____ feet of stone below distribution pipe.
LOCATION:	Install Advantex tank after existing tank in line with existing drywell. Old tank to be pumped and collapsed.
NOTES:	This permit under the BRF BAT for the installation of an AdvanTex AX 20 model 3a unit.

PLANS APPROVED: K. Wolf DATE: 4/29/2009

- NOTE: PERMIT VOID AFTER 2 YEARS
- NOTE: CONTRACTOR RESPONSIBLE FOR SCHEDULING A PRE-CONSTRUCTION INSPECTION FOR ALL INSTALLATIONS
- NOTE: WATERTIGHT SEPTIC TANKS REQUIRED
- NOTE: ALL PARTS OF SEPTIC SYSTEM SHALL BE 100 FEET FROM ANY WATER WELL
- NOTE: MANHOLE RISERS REQUIRED ON ALL SEPTIC TANKS AND PUMP CHAMBERS UNLESS SPECIFICALLY AUTHORIZED

**NEITHER THE HOWARD COUNTY COUNCIL NOR THE HEALTH DEPARTMENT IS
RESPONSIBLE FOR THE SUCCESSFUL OPERATION OF ANY SYSTEM
PERMITTEE RESPONSIBLE FOR OBTAINING FINAL APPROVAL ON THIS PERMIT
CALL 410-313-2640 FOR INSPECTION OF SEPTIC SYSTEM**

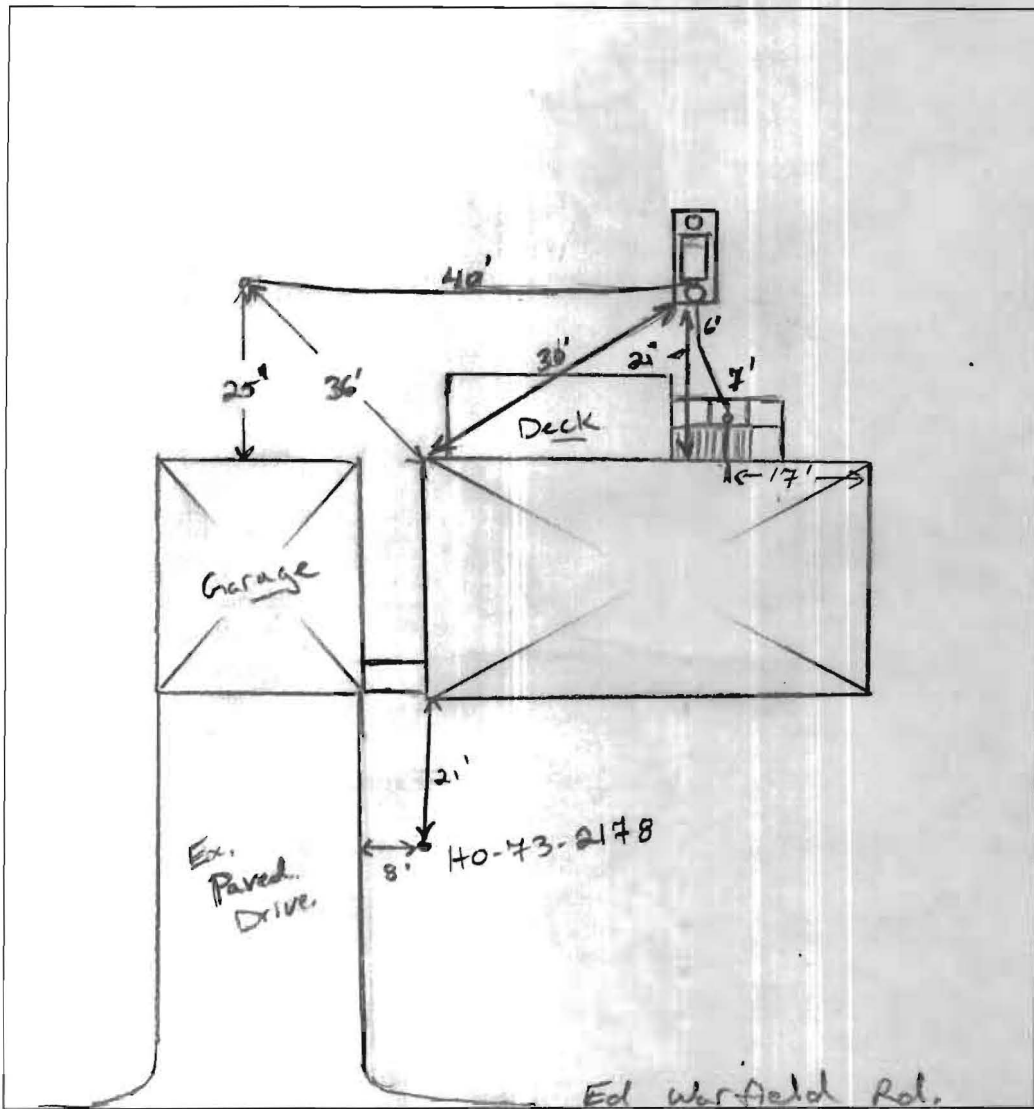

TRENCH/DRAINFIELD DATA

(If Installed/Needed)

WIDTH _____ INLET _____ BOTTOM _____

NUMBER OF TRENCHES _____

TOTAL LENGTH _____

ABSORPTION AREA _____

DIST. BOX LEVEL _____

DIST. BOX BAFFLE _____

DIST. BOX PORT _____

AdvanTex AX 20 Model 3a.

BAY RESTORATION FUND

MANUFACTURER Boystar

CAPACITY 1500 GAL

SEAM LOC Top

TANK LID DEPTH 3'

BAFFLES Yes

BAFFLE FILTER Yes

MANHOLE LOC Front / Rear

6" PORT LOC None

WATERTIGHT TEST _____

~~STARTUP~~ TEST OK

~~High 16.0~~ ALARM TEST OK

DATE ON LID Yes

(4/21/09) Received phone call from contractor to set up insp. for today. I told him that we received the correct Agreement & easement forms but have not received engineered drawing of ATU to be installed.

(4/30/09) Contractor had installed the ATU on 4/21/09 after I spontaneously told him that we did not receive all the info to release the permit. Engineered drawing received 4/29/09 so permit taped up and ready for release. Installation looks good. start up test and looks good. Waiting for letter of approval from AdvanTex.

FINAL INSPECTOR J. Hall

DATE OF APPROVAL 4-30-09

Tim McIntosh
16058 Edwarfield Rd
Woodbine MD
21797

Scale 1:30

Howard County Health Department
Bureau of Environmental Health
7178 Columbia Gateway Drive
Columbia, Maryland 21046

Approved Septic System Plan
Howard County Health Department

BRF

[Signature]
Signature

4/28/09
Date

Site plan ok to
set BAT Advantex
AX 20 mech 3c unit

4' Top Dry well



Advantex 1500
3' to top



Old Septic tank

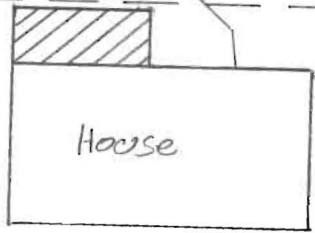

75' to the Road

SITE INSPECTION SHEET

OWNER: Jim McIntosh PHONE #: _____
ADDRESS: 16058 Ed Warfield CONTRACTOR: _____
WELL TAG #: HO-43-217B
SUBDIVISION: _____ LOT: _____ COUNTY #: 13
PROPOSAL: BRF site visit

LOCATION DIAGRAM

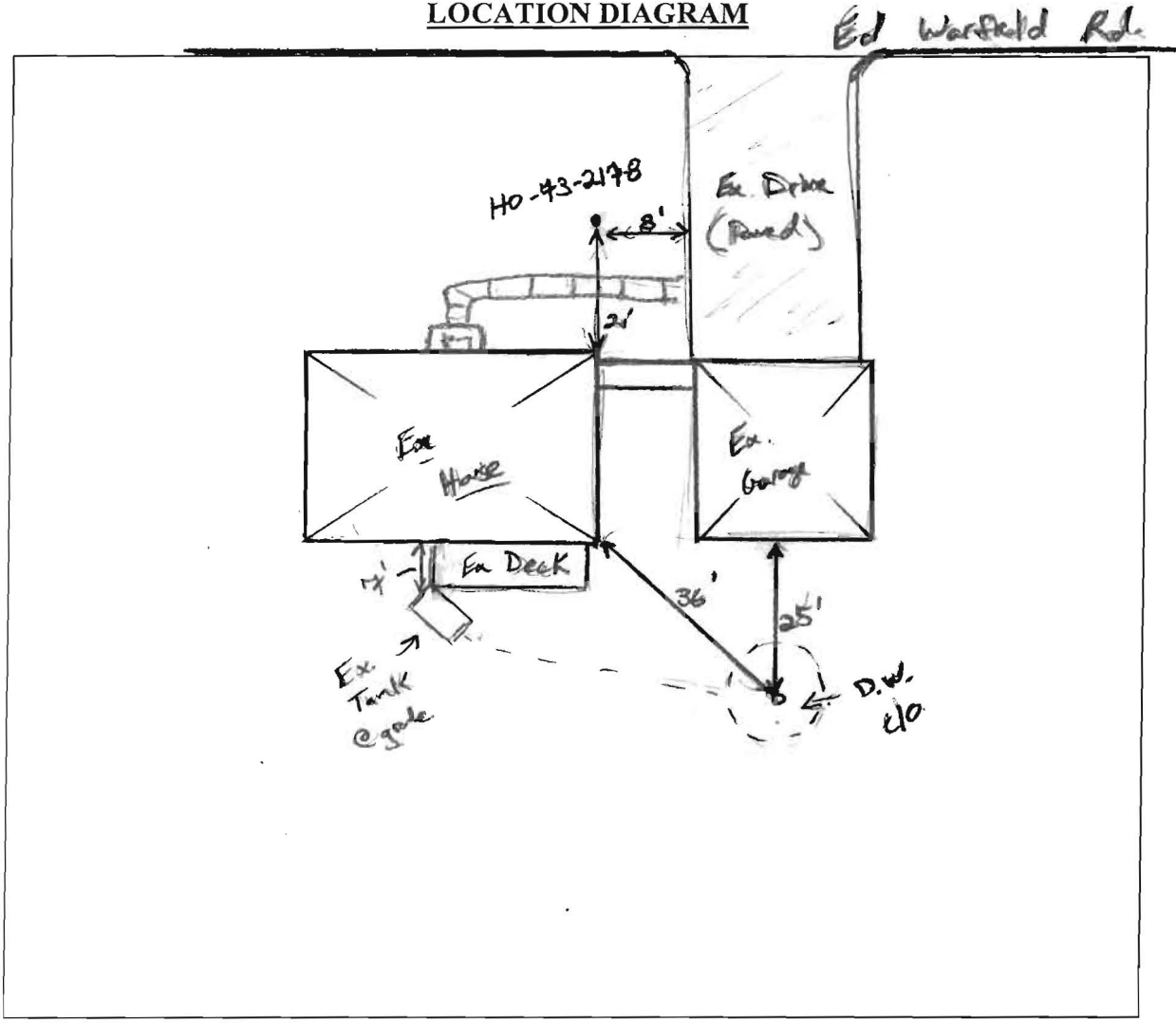

COMMENTS: Existing well up to code. Existing Septic tank @ grade. Could not open clo to DWS. New BAT tank will probably encroach w/ in 100' of well Radius. (KW)

DATE: 4/16/09 INSPECTOR: K. Wolf



* KEEP W/ FILE !!

AdvanTex® Field Maintenance Report Start-Up Summary Report

Atlantic Solutions, MD
(401) 293-0176

Property Owner/Tracking # Tim McIntosh		Operator Owen Townley		Installed Date 4/28/2009	
Site Address 16058 Ed Warfield Road, Woodbine MD 21797					Start-Up Date 4/28/2009
Phone Number (301) 231-1739	Permit #	Model 3A	Bedrooms 3	Occupants 2	Occupancy Date
Designer/Engineer Atlantic Solutions		Phone 401-293-0176		Authorized Installer Chief Septics	
Phone 401-293-0176		Electrical		Phone 410-635-3237	

Primary Treatment

If using a single Processing Tank, complete the following:

Processing Tank

Septic Volume (6000 gal.) Reclro Volume (500 gal.)

Construction Concrete Fiberglass Other

Manufacturer: Baystar

If using a separate Septic Tank and Reclro Tank, complete the following:

Septic Tank (_____ gal.)

Construction Concrete Fiberglass Other

Manufacturer: _____

Reclro Tank (_____ gal.)

Construction Concrete Fiberglass Other

Manufacturer: _____

Pump Model: PF300S11

Floats set property at 11 in. 13 in. 24 in.

Secondary Treatment

RSV setting: 14 in.

Residual head measurement:

Pod #1 4'0" in. Pod #2 _____ in. Pod #3 _____ in.

Discharge Tank/Basin (_____ gal.)

Construction Concrete Fiberglass PVC (Basin)

Manufacturer: _____

Pump Model: _____

Floats set property at _____ in. _____ in. _____ in.

Discharge pump flow rate (drawdown test): (_____ gpm)

Discharge pump dose volume: _____ gal./dose

Comments _____

Signature [Signature]

Date 4/28/2009

Fax completed form to 1-866-384-7404

Control Panel

Panel ID (RTU or UL #) 116417	"On" Timer Setting 0.3	"Off" Timer Setting 19.7
----------------------------------	---------------------------	-----------------------------

Filter Pods

Pod #1 Serial No. 408086	Pod #2 Serial No.	Pod #3 Serial No.
-----------------------------	-------------------	-------------------

Other System Components

Disinfection equipment (manufacturer): _____

Disposal system (type of):

GRAVITY

Declarations (Initial)

OT Orenco's Start-Up Procedure was followed.

OT All lids are secured.

OT Circuit breakers are on and control panel is latched.

OT "For Service Call" label with phone # was affixed to panel.

OT Homeowner Package was reviewed with:

Builder on (date) 4/28/2009

Resident on (date) _____

The system is ready for use Yes No (explain)

1500 GALLON SEPTIC TANK

TWO COMPARTMENT

used with AdvanTex Treatment System

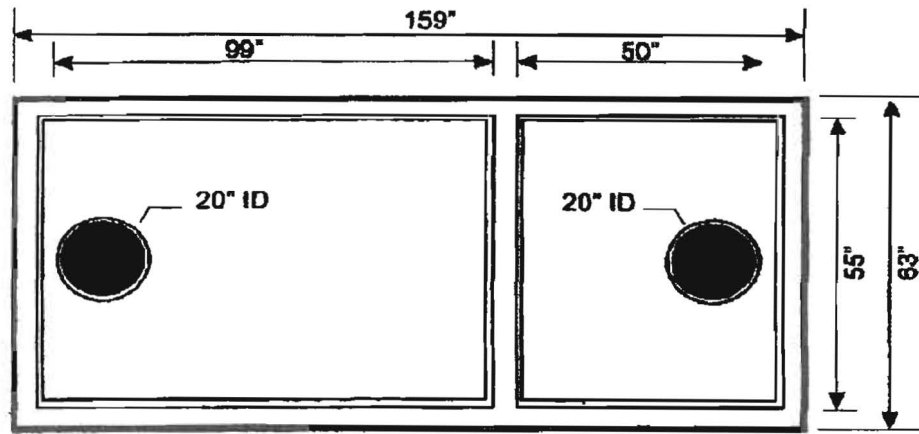

TOP VIEW

ORENCO RISER ADAPTER POURED IN TOP SLAB
MUST USE ORENCO RISERS AND COVERS
SEALED WITH CONSEAL CS-101

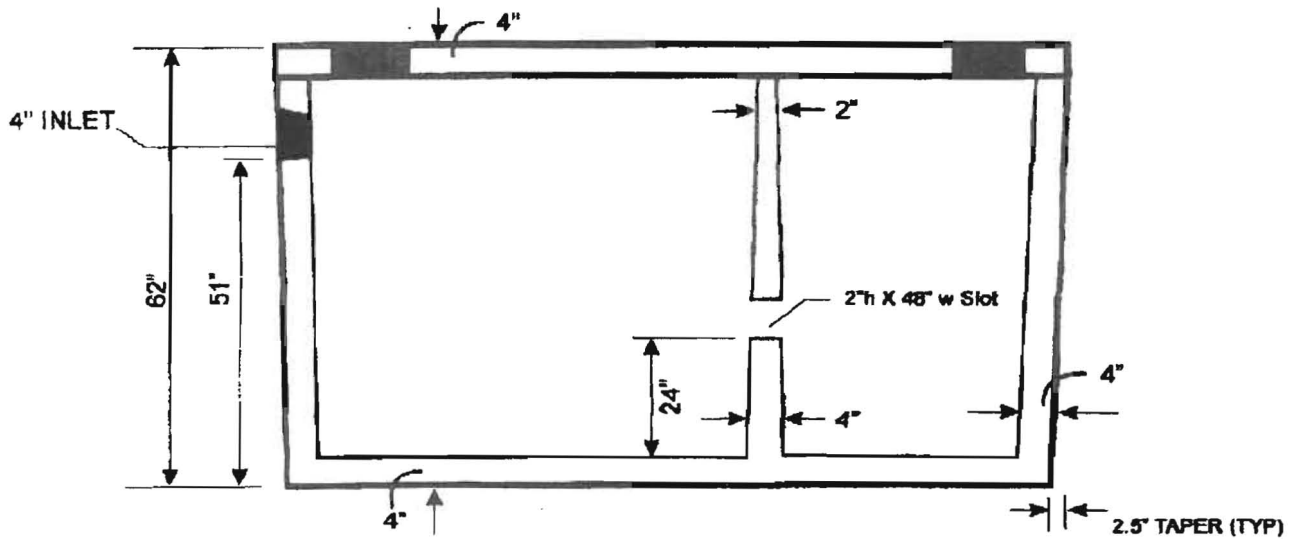

SECTION VIEW

Since  **BAYSTAR** 1989
PRECAST CORPORATION

925 Skidders Turn Road
P.O. Box 959
Owings, Maryland 20736-0959

800.481.0683
410.257.8777
301.886.8777
fax: 410.257.1312

GENERAL NOTES:

1500 GALLON SEPTIC TANK

TWO COMPARTMENT

used with Advantex Treatment Systems

CONCRETE STRENGTH 4000 PSI AT 28 DAYS
REINFORCING DETAIL: 6X6 #10 GAUGE WIRE MESH;
TOP HAS #3 BARS 6" O.C.; SIDES AND BOTTOM HAVE #3
BARS 12" O.C.

Date Appr.
041808

1500 2C Advantex

Drawing not
to scale

AdvanTex™ Treatment System AX 20 Series - Mode 3a

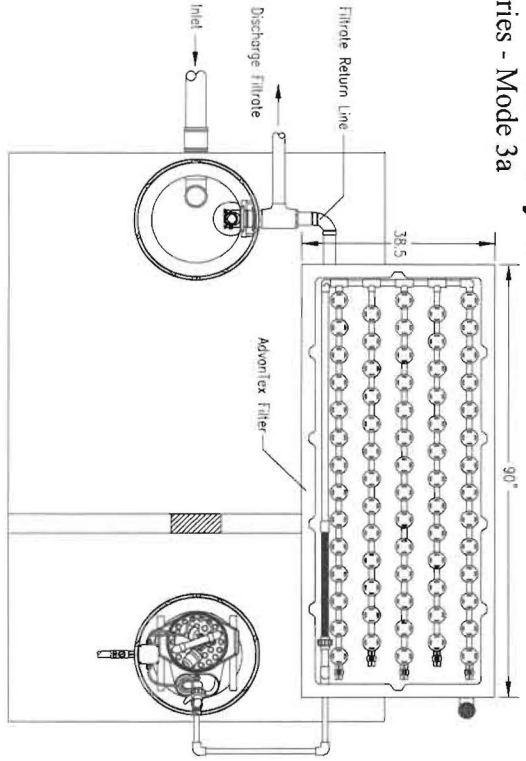

Top View

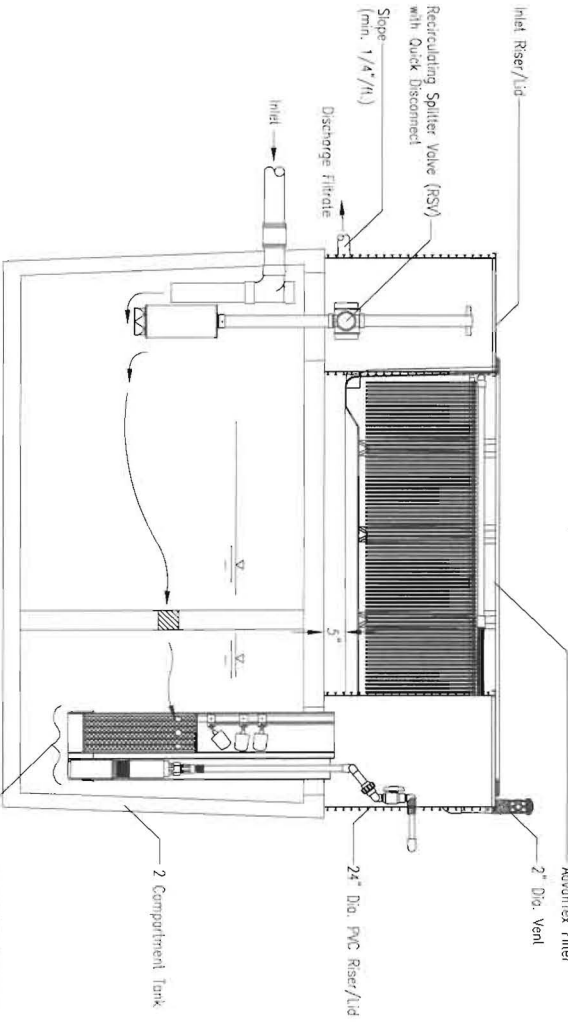

Side View

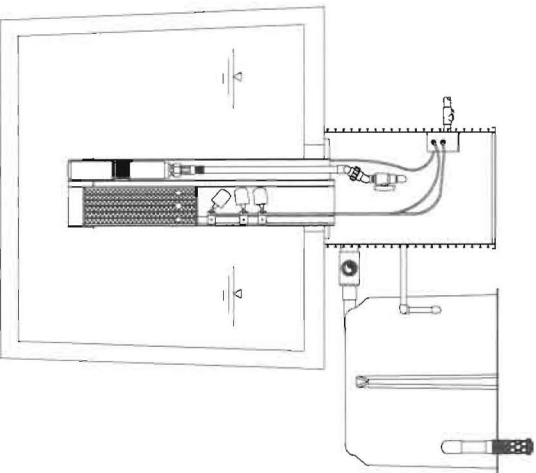

End View

*model upgrade for BRP
16058 Ed. Winfield. Ad.
3-4 BR.*

U.S. Patents 5,531,894 and 5,480,561 4,459,323 and 5,492,633 Other Patents Pending © 2001 Orenco Systems® Inc.	Designed By: ENGINEERING	Drawn By: CHRIS JORDAN	Title: AdvanTex™ - AX 20 Mode 3A		 Orenco Systems® Incorporated
	Approved By:	Drawing: 1 OF 1	Drawing No. NDW-ATX-AX20-3A		
	Date Approved:	Revision: 2.0	Date: 1/15/04	Scale: 1" = 2'-0"	

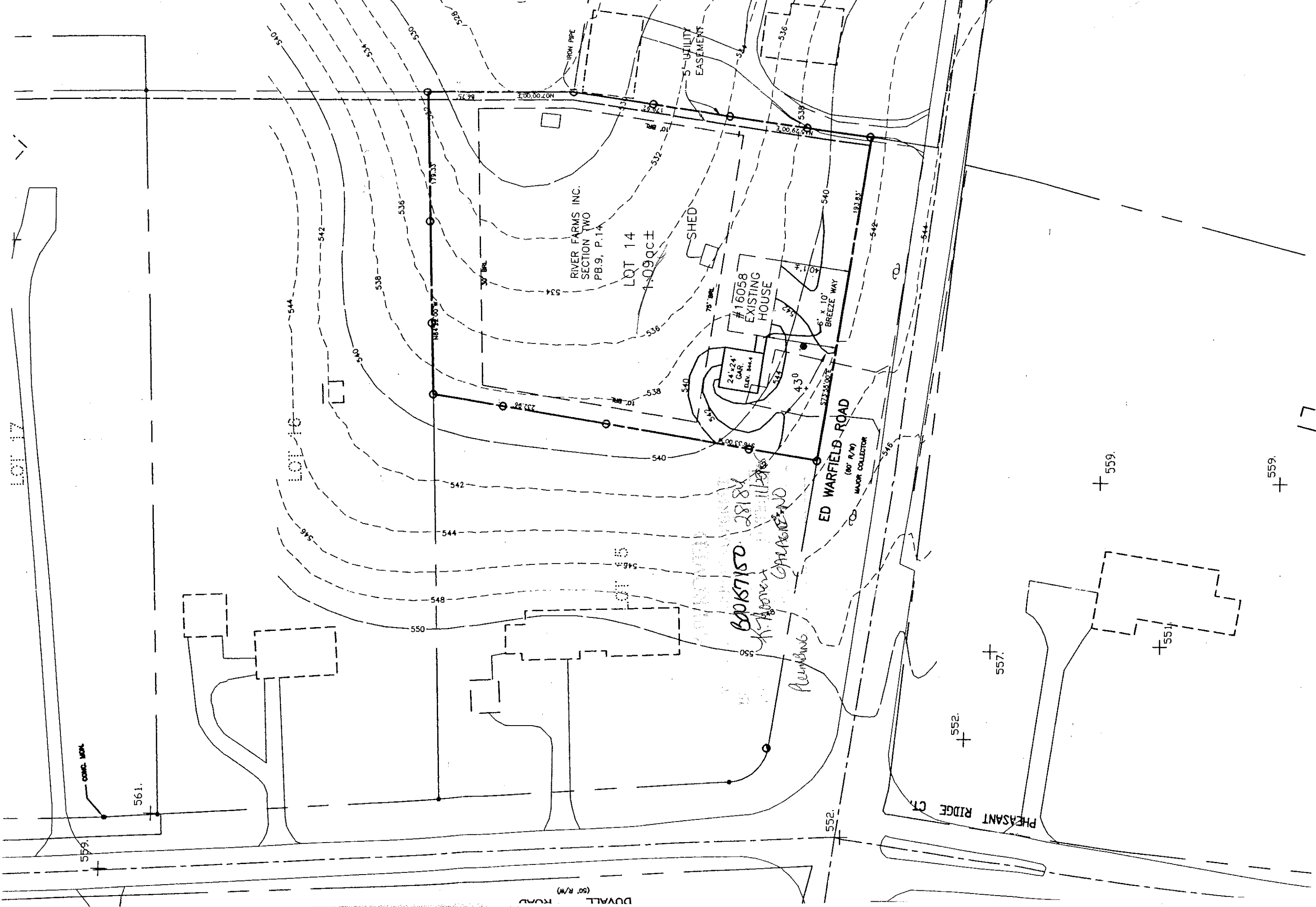

17
 PLAN VIEW
 SCALE: 1" = 50'

LIBER 11668 FOLIO 005

AGREEMENT AND EASEMENT FOR INSTALLATION OF BEST AVAILABLE TECHNOLOGY SYSTEMS WITH BAY RESTORATION FUNDS.

000160

THIS AGREEMENT is made this 19th day of March, among Tim McIntosh, hereinafter referred to as "Owner," the Howard County Health Department hereinafter collectively referred to as the "County," and the Department of the Environment, hereinafter referred to as the "Department."

WHEREAS, Owner owns a tract of land located on 16058 Ed Warfield Road, in the 4th Election District of Howard County, Maryland, and the deed to same is recorded among the Land Records of Howard County, Maryland, in Ellicott City and in Liber 10181 Folio 217.

WHEREAS, the Bay Restoration Fund (BRF) may provide a grant for the cost attributable to upgrading an onsite sewage disposal system to the Best Available Technology (BAT) for the removal of nitrogen.

WHEREAS, the BRF may also provide a grant for the cost difference between a traditional onsite sewage disposal system and a system that utilizes the BAT for the removal of nitrogen.

WHEREAS, Owner understands that participation in the Bay Restoration Fund

THE FD SURE \$ 20.00
RECORDING FEE 28.00
TOTAL 48.00
Rec'd HOBC Acct # 52834
NOR CLR Blk # 1454
Apr 17 2009 02:22 PM

NOW, THEREFORE, the parties hereto agree as follows:

- A. Owner hereby grants to the Department and the County the right to enter upon the property at any reasonable time for access to the system to make periodic inspections and the Owner agrees to provide any information and data requested and needed by the Department to develop accurate and thorough test results.
B. Owner acknowledges and agrees that a manufacturer-approved installer will install the BAT system.
C. Owner acknowledges and agrees the manufacturer will provide for Operation and Maintenance of the BAT for a period of 5 years as a condition of sale of the BAT. After the 5 year

LIBER 11668 FOLIO 006

- period the Operation and Maintenance contract can be further extended at the behest of the property owner. The Department and County encourage the property owner to continuously maintain an Operation and Maintenance contract during the lifetime of the system.
- D. Owner acknowledges and agrees that the manufacturer appointed Operation and Maintenance provider will have access to the BAT system at all times.
- E. Owner acknowledges and agrees that the manufacturer or manufacturers designee will have access to sample the effluent of the BAT system. Owner acknowledges and agrees that the proposed installation of a BAT system funded by the BRF is voluntary. Owner agrees that there shall be no liability on the part of the County or Department to Owner if this BAT system fails, and that the County and the Department do not warrant or guarantee that the BAT system will adequately or properly function.
- F. Owner acknowledges and agrees that neither the County nor the Department nor any of its agents or employees, either officially or individually, underwrites the operation of any system approved by them.
- G. The Owner will devote such care and effort to the maintenance of the BAT system so that any malfunction is not the result of poor maintenance, faulty operation, or neglect.
- H. The Department agrees to grant \$ 12,463.00 toward the cost of installation of the BAT System, and financial responsibility is limited to this amount. Owner will present to the Department at least 3 proposals from manufacturer and County certified system installers demonstrating the total cost of installation. Operating costs will be at the Owner's expense.
- I. The Owner acknowledges that the BRF grant can only be used for that portion of the OSDS attributable to (BAT) for the removal of nitrogen.

UECA 11668 FOLD 007

- J. Owner acknowledges in the event the total project cost is greater than \$25,000 the proposal will have to be approved by the Maryland State Board of Public Works.
- K. The Owner agrees to contact both the Water Management Administration, On-Site Systems Division of the Wastewater Permits Program and the County at least forty-eight (48) hours prior to system installation, so that the Department has the opportunity to be present at the time of installation or thereafter for inspection.
- L. The Owner must install BAT system according to the manufacturer recommended plans and specifications approved by the Department.
- M. The Owner agrees and acknowledges that if installation deviates substantially from the approved plans or changes such that performance of the system is compromised or reduced, BRF funding will not be provided.
- N. This agreement shall run with the land and binds the Owner, his heirs, successors, assigns except that the provisions of paragraph A, C, D and E shall be binding for a period of 5 years only after installation of the system and occupation of the home. Owner further agrees that he shall inform in writing any purchaser or lessee of the property that the system may require maintenance or other attention. The Owner agrees to record this agreement in the land records of Howard County.
- O. This agreement shall not be construed to limit any authority of the Department to protect the public health, safety or comfort or to issue any other orders to take any other action that is now or may hereafter be within its authority.
- P. This agreement may be voided at the discretion of the Department if the system construction is not completed within six (6) months of the effective date of this agreement.
- Q. This agreement contains the entire agreement and understanding between the County and the Owner and the Department. There are no additional terms other than as contained in this

LABOR 11668 FOLIO 008

agreement. This agreement may not be modified except in writing signed by each of the parties or by their authorized representatives.

R. The laws of the State of Maryland govern the provisions of all transactions pursuant to this agreement.

IN WITNESS WHEREOF, the parties have signed and sealed this agreement on the date indicated above.

DATE: 4/1/2009

Tim McIntosh
Owner Tim McIntosh

DATE: 3/20/09

Jay Pinger
Jay Pinger, Deputy Program Manager
Wastewater Permits Program
Maryland Department of the Environment

DATE: 4/9/09

Beit Rifan
Howard County Health Department

Re



MARYLAND DEPARTMENT OF THE ENVIRONMENT

1800 Washington Boulevard • Baltimore MD 21230
410-537-3000 • 1-800-633-6101

Martin O'Malley
Governor

Anthony G. Brown
Lieutenant Governor

March 19, 2009

Tim C. McIntosh
16058 Ed Warfield Road
Woodbine, MD 21797

RE: Tax Map 13, Grid 18, Parcel 96, Lot 14

Dear Mr. McIntosh:

Your bid package for the Bay Restoration Fund (BRF) Onsite Sewage Disposal System (OSDS) Program has been approved for the use of funds totaling not more than \$12,463.00. The accepted bid amount is for the installation of a Hoot by Chief Septic for your property located at 16058 Ed Warfield Road. You may choose to deviate from the selected unit, however the grant award for acceptable reimbursable expenses may not exceed \$12,463.00. All grants awarded through the Maryland Department of the Environment (MDE) are reimbursable. This means that all work done prior to this letter cannot be considered for reimbursement. In order to be eligible for reimbursement you must sign and record a copy in the land records of Howard County the Agreement and Easement for Installation of Best Available Technology Systems with Bay Restoration Funds. You must provide MDE with the following:

- The contractor's and manufacturer's invoice. These invoices should include everything quoted in the bid. All expenditures greater than the bid amount will not be covered.
- A copy of the installation inspection performed by the Howard County Environmental Health program.
- A completed State Grant or Loan Payment Disbursement Request Form
- A copy of the Agreement and Easement for Installation of Best Available Technology Systems with Bay Restoration that shows that it has been recorded in the land records of Howard County.

All submitted documentation would be reviewed for compliance. Once all documentation is submitted, you will receive a payment directly from the State Comptroller's office.

The Maryland Department of the Environment thanks you for participating in this important program. If you have any further questions, please feel free to contact me at 410-537-3678 or 800-633-6101 ext 3678 or email at jboris@mde.state.md.us.

Sincerely,

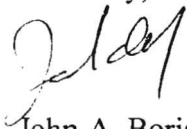

John A. Boris, Jr., R.S.
Bay Restoration Fund Project Manager

Enclosure

cc: Jay Prager
Steve Krieg, Regional Consultant
Howard County Health Department



Bureau of Environmental Health
7178 Columbia Gateway Drive, Columbia, MD 21046-2147
(410) 313-2640 Fax (410) 313-2648
TDD (410) 313-2323 Toll Free 1-866-313-6300
website: www.hchealth.org

Peter L. Beilenson, M.D., M.P.H., Health Officer

March 5, 2009

Tim C. McIntosh
16058 Ed Warfield Rd.
Woodbine, Maryland 21797

RE: Bay Restoration Fund On-site Sewage Disposal
System Program

Dear Mr. McIntosh,

The Health Department received your preliminary approval letter from the Maryland Department of the Environment for funding from the Bay Restoration Fund. This funding is for the installation of best available technology (BAT) for removing nitrogen as part of your on-site sewage disposal system.

Once the specific technology has been determined and approved by the Maryland Department of the Environment, you or your consultant will be responsible for providing a detailed cross-sectional/spec sheet of what is proposed to be installed at your property, i.e. new tank, BAT to be used with existing tank, etc. If a new tank is to be used, a drawing showing the new, detailed tank along with a profile showing the depth and amount of earth cover shall be submitted to this office. These details should be available from the manufacturer. If the existing tank is to be used, a structural analysis of the tank, i.e. water tightness, mid or top seam, cosmetic or physical damage, slotted, etc., needs to take place and approved by the manufacturer.

In addition, a scaled site plan showing the exact locations of the well and septic components, i.e. septic tank and dry well, must be submitted to this department for review. Neighboring septic systems and wells may need to be included on the site plan. Elevations of system components may be required based on site characteristics. Also submit contact information of the contractor that is to install the system, including a phone number. BAT systems may be subject to Howard County Health Department Code and the Annotated Code of Maryland Regulations (COMAR), i.e. setback to dwelling, existing drive, existing well, slopes, etc.

Once these comments have been addressed and allocated by the Health Department for completion in its entirety, the septic permit can then be released. A fee of \$396.00 is required to receive this septic permit for the above referenced property.

If you have further questions regarding this matter, please contact me at (410) 313-1771.

Sincerely,

Sara Sappington, R.S.
Well and Septic Program



MARYLAND DEPARTMENT OF THE ENVIRONMENT

MDE

1800 Washington Boulevard • Baltimore MD 21230

410-537-3000 • 1-800-633-6101

Martin O'Malley
Governor

Shari T. Wilson
Secretary

Anthony G. Brown
Lieutenant Governor

Robert M. Summers, Ph.D.
Deputy Secretary

February 3, 2009

Tim C. McIntosh
16058 Ed Warfield Rd,
Woodbine, Maryland 21797

RE: Tax Map 13, Grid 18, Parcel 96

we have an ass-suet

Dear Tim C. McIntosh:

Thank you for completing an application for the Bay Restoration Fund (BRF) Onsite Sewage Disposal System (OSDS) Program. The pre-application submitted is for your property located at 16058 Ed Warfield Rd, Woodbine, Maryland 21797 and shown on Map 13, Parcel 96. A review of the application indicates a high priority for funding. This letter is to notify you of preliminary approval for funding from the BRF for the installation of best available technology (BAT) for removing nitrogen as part of your on-site sewage disposal system.

This notification letter is intended to assist you through the process of obtaining proper BAT installation bids and invoicing procedures to obtain funding from the BRF. The following sections outline the requirements necessary for proceeding with the project.

Submission of Bids

The applicant must acquire bids from at least three separate manufacturers and at least 2 different installers for a minimum total of 3 bids to MDE for review. The installer can act as agent on behalf of the applicant but still must also supply a separate installer bid. A list of manufacturers is included in this letter. If you need additional participating installer information please contact your designated Project Manager or go to http://www.mde.state.md.us/Water/CBWRF/osds/bat_installers.asp for a list of installers. Bids must include the following:

- The installer, whether they are a manufacturer representative or one chosen by the property owner, must submit a separate installation quote with each manufacturer bid on a separate piece of paper from the manufacturer quote or the bid will be considered incomplete.
- Bids must be itemized. The manufacturer bid is to include the purchase cost of the unit and all other MDE requirements while the installation cost of the unit is to include the unit installation, components, and labor (including electrical connections) directly related to upgrading an onsite sewage disposal system to the best available technology for removing nitrogen are eligible for funding.

The following BAT Technologies have undergone MDE review and are eligible for BRF grants:

Model Name			
AdvanTex AX			
Manufacturer:	Orenco Systems, Inc.	www.orenco.com	
Distributor:	Robert Johnson	1-877-214-92837	bjohnson@septicssystems.net
Amphidrome			
Manufacturer:	F.R. Mahony & Associates, Inc.	www.frmahony.com	
Distributor:	David Kershner	(610) 351-0963	d.kershner@ketllc.com
Bioclere			
Manufacturer:	Aquapoint, Inc.	www.aquapoint.com	
	Robbie Tippett	(240) 298-7572	rtipp4@aol.com
	Sam Seymour	(585) 473-3300	sseymour@aquapoint.com
Ecoflex			
Manufacturer:	Premier Tech Environment		
	Allison Blodig	(785) 250-3215	bloa@premiertech.com
Hoot H-Series, BNR & ANR			
Manufacturer:	Hoot Aerobic Systems, Inc.	www.hootsystems.com	
Distributor:	Nancy Mayer	(410) 796-1434	mayerbro@connext.net
MicroFAST & RetroFAST			
Manufacturer:	Bio-Microbics, Inc.	www.biomicrobics.com	www.freemire.com
Distributor:	Freemire & Associates	(410) 768-8500	rsf@freemire.com
Nitrex			
Manufacturer:	Lombardo Associates, Inc	www.lombardoassociates.com	
	Pio Lombardo	(617) 964-2924	pio@lombardoassociates.com
ReCip RTS			
Manufacturer:	Bio-Concepts, Inc.	www.bioconceptsinc.com	
	Al Privette	(252) 249-7040	alprivette@coastal.net
SeptiTech			
Manufacturer:	SeptiTech, Inc.	www.septitech.com	
Distributor:	Bruce Melton	(410) 878-2952	rbmelton@progressiveseptic.com
	Western MD, Scott Everhart	(304) 676-3823	www.cseenterprises.net
Singular Model TNT			
Manufacturer:	Norweco, Inc.	www.norweco.com	
Distributor:	Eastern Shore - Randy Clark	(800) 773-9128	ranjodan@yahoo.com
	Western Shore - Jeff Earnshaw	(301) 274-3772	superiortank@olg.com
Waterloo Biofilter			
Manufacturer:	Waterloo BioFilter Systems, Inc.	www.waterloo-biofilter.com	
Distributor:	Jones Pump Service	(410) 836-9206	manager@jonespumpservice.com

Conditions of Financial Assistance

By reading and signing this form, you agree to the limitations and conditions set forth in this document. This form must be returned with your submission of bids. Your bid submission will not be processed if this form does not accompany the bids when you submit them.

Award of Grant

- MDE will review the bids. The grant award will be obligated based on the lowest acceptable bid, however the applicant may pay the cost difference of a more expensive bid.
- The applicant will be notified by MDE as to the amount of the grant obligation and with further instructions as to how to pursue reimbursement of obligated funds.
- For awards greater than \$25,000 MDE must present a proposal to the Board Public Works for approval.
- No change orders will be accepted by MDE.
- The award amount is available for reimbursement within 6 months of Department signature on the Agreement and Easement document. Upon request of the applicant, the original 6-month period may be extended at the discretion of the Department.

Agreement and Easement

An Agreement and Easement must be completed, signed by all parties and recorded in the Land Records of Howard County Maryland. A draft copy of the Agreement and Easement is provided to you in this letter for your review. A completed Agreement will be provided to you after bids are submitted to MDE when you are notified of the grant approval amount. The purpose of this Agreement is to accomplish the following:

- To establish your voluntary participation in this program.
- To ensure that a minimum of five years operation and maintenance is performed by an approved provider (included in the upfront cost of the system).
- Allows access for State, County and the Manufacturer designee's to inspect and collect samples from the system.
- Establishes the amount of the grant award.

Local Permitting Requirements

- All required local permits must be obtained.
- Permit fees are not eligible for BRF funding.
- Contact Howard County Health Department for more information.

Issuance of Funds from the BRF

After review of the submitted invoice and associated documents, the Office of the Comptroller of the State of Maryland will issue a check to the property owner.

Once again the Department thanks you for participating in this important program. If you have any questions, please feel free to contact me at 410-537-3678 or by email at jboris@mde.state.md.us.

Sincerely,



John Boris
Bay Restoration Fund Project Manager

Enclosure

cc: Jay Prager, Deputy Program Manager
Steven Krieg, Regional Consultant
Howard County Health Department

154700